

**TECHNICAL MANUAL
OPERATOR'S, UNIT,
DIRECT SUPPORT, AND GENERAL SUPPORT
MAINTENANCE MANUAL**

**PUMP UNIT, CENTRIFUGAL,
DIESEL ENGINE DRIVEN,
SELF PRIMING, 65 GPM WATER
MODEL 4M SDQ 2000
NSN 4320-01-338-8010**

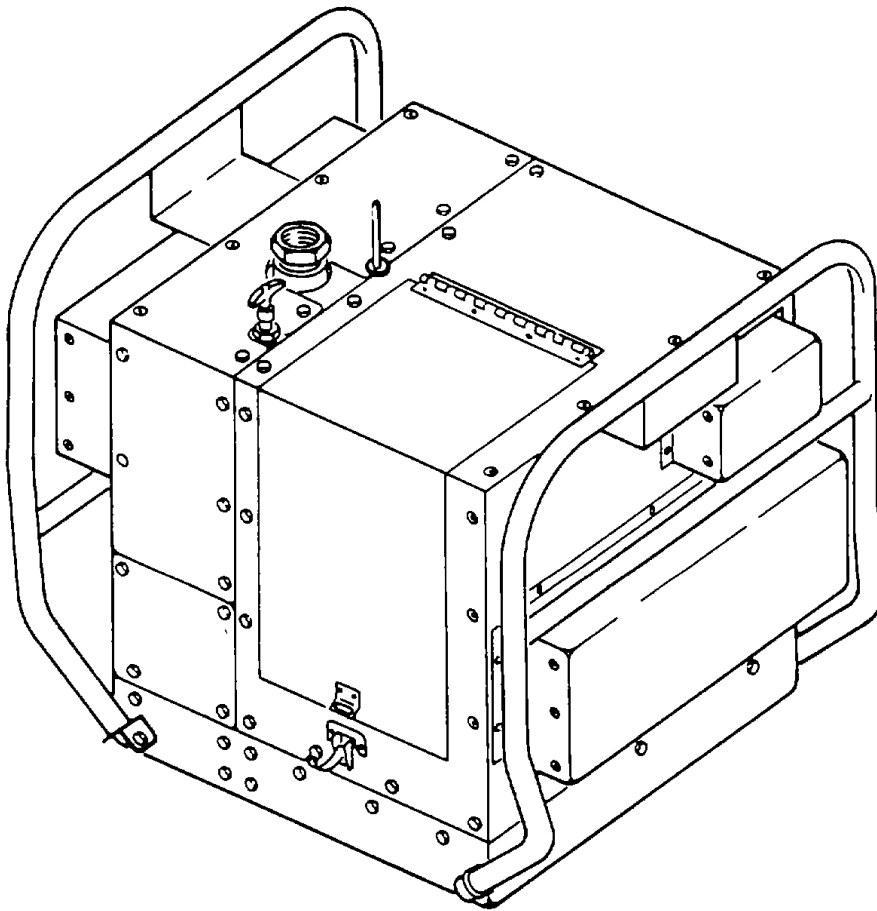

INTRODUCTION 1-1

**OPERATING
INSTRUCTIONS 2-1**

**OPERATOR
MAINTENANCE 3-1**

**UNIT
MAINTENANCE 4-1**

**DIRECT SUPPORT
MAINTENANCE 5-1**

**GENERAL SUPPORT
MAINTENANCE 6-1**

**COMPONENTS OF
END ITEM LIST C-1**

ALPHABETICAL INDEX

Distribution Statement A: Approved for public release; distribution is unlimited.

**HEADQUARTERS, DEPARTMENT OF THE ARMY
18 JANUARY 1994**

WARNING**CARBON MONOXIDE (EXHAUST GAS) CAN KILL YOU**

Carbon monoxide is without color or smell, but can kill you. Breathing air with carbon monoxide produces symptoms of headache, dizziness, loss of muscular control, a sleepy feeling, and coma. Heavy exposure can cause brain damage or death. Carbon monoxide gas occurs in the exhaust fumes of internal combustion engines, and can become dangerously concentrated under conditions of no air movement. To ensure your safety and that of other maintenance personnel, always observe the following precautions:

- DO NOT operate engine in a closed place unless the place has a lot of moving air. Engine should be kept at least five feet away from buildings and other equipment during operation.
- DO NOT idle engine for long periods without proper ventilation.
- BE ALERT at all times for exhaust odors and exposure symptoms. If either is present, IMMEDIATELY VENTILATE personnel compartments; remove affected crew to fresh air; keep warm; if necessary, give artificial respiration. FOR ARTIFICIAL RESPIRATION REFER TO FM 21-11.
- BE AWARE; the field protective mask for chemical-biological-radiological (CBR) protection will not protect you against carbon monoxide poisoning.

THE BEST DEFENSE AGAINST CARBON MONOXIDE POISONING IS GOOD VENTILATION.

WARNING

Mishandling fuel could result in death or serious injury. Engine must be turned off and cool before refueling. Use proper refueling procedures and equipment to avoid spillage. Wipe away fuel spills with a clean cloth. Refuel only in a well-ventilated area away from open flame, arcing equipment, ignition sources, heaters, or excessive heat. Do not run engine near open fuel containers. Always store fuel in properly, marked containers. DO NOT SMOKE when refueling.

WARNING

Touching or handling heated parts will cause severe injury to operating personnel. Muffler and related components get hot enough during pump operation to cause severe burns. Avoid contact with muffler and related components during repair procedures described in this text. Do not perform any repair procedures until the unit has cooled down sufficiently.

WARNING

Operating engine without protective covers could result in serious injury. If any item becomes loose or cracked, immediately stop the engine and repair. After completing any "Remove, Replace, or Repair" procedures ensure that protective covers are reinstalled before operating the pump.

WARNING

Misuse of compressed air could result in death or serious injury. Death or serious injury could occur if compressed air is directed against skin. Do not use compressed air for cleaning or drying unless the pressure is/has been reduced to 30 PSI or less. When working with compressed air, always use eye protection and any other protective equipment.

WARNING

Lifting or moving heavy equipment can cause serious injury. Do not try to lift or move more than 50 pounds by yourself. Get an assistant. Bend legs while lifting. Don't support heavy equipment with your back.

Always use assistants during lifting operations. Use guide ropes to more hanging assemblies.

A lack of attention or being in an improper position during lifting operations can result in serious injury or death. Pay close attention to movements of assemblies being lifted. Do not stand under lifted assembly or in a position where you could be pinned against another object. Watch your footing

Hoist used to lift pumping assembly must have a minimum lifting capacity of 750 pounds.

FIRST AID

Refer to FM 21-11 for first aid procedures.

**Operator's, Unit, Direct Support,
and General Support Maintenance Manual**

For

**PUMP UNIT, CENTRIFUGAL, DIESEL ENGINE DRIVEN,
SELF-PRIMING, 65 GPM WATER
MODEL 4M SDQ 2000
NSN 4320-01-338-8010**

REPORTING ERRORS AND RECOMMENDING IMPROVEMENTS

You can help improve this manual. If you find any mistakes or if you know of a way to improve the procedures, please let us know. Mail your letter, DA Form 2028 (Recommended Changes to Publications and Blank Forms) or DA Form 2028-2 located in the back of this manual direct to: Commander, U. S. Army Aviation and Troop Command, ATTN: AMSAT-I-MP, 4300 Goodfellow Blvd. , St. Louis, MO. 63120-1798. A reply will be furnished to you.

TABLE OF CONTENTS

	Page
How To Use This Manual	vii
CHAPTER 1. INTRODUCTION	1-1
Section I. General Information	1-1
Section II. Equipment Description and Data	1-2
Section III. Principles of Operation	1-5
CHAPTER 2. OPERATING INSTRUCTIONS	2-1
Section I. Description and Use of Operator's Controls and Indicators.....	2-2
Section II. Operator Preventive Maintenance Checks and Services	2-4

DISTRIBUTION STATEMENT A: Approved for public release; distribution is unlimited

TABLE OF CONTENTS - Continued

	Page
Section III. Operation Under Usual Conditions	2-12
Section IV. Operation Under Unusual Conditions	2-20
CHAPTER 3. OPERATOR MAINTENANCE INSTRUCTIONS	3-1
Section I. Lubrication Instructions	3-1
Section II. Operator Troubleshooting Procedures	3-1
Section III. Operator Maintenance Procedures	3-5
CHAPTER 4. UNIT MAINTENANCE INSTRUCTIONS	4-1
Section I. Repair Parts, Special Tools; Test, Measurement, and Diagnostic Equipment, and Support Equipment	4-1
Section II. Service Upon Receipt and Preparation for Movement	4-1
Section III. Lubrication	4-4
Section IV. Unit Preventive Maintenance Checks and Services (PMCS)	4-5
Section V. Unit Troubleshooting Procedures	4-9
Section VI. Unit Maintenance Procedures	4-15
Section VII. Preparation for Storage or Shipment	4-84
CHAPTER 5. DIRECT SUPPORT MAINTENANCE INSTRUCTIONS	5-1
Section I. Repair Parts, Special Tools; Test, Measurement, and Diagnostic Equipment (TMDE), and Support Equipment	5-1
Section II. Direct Support Troubleshooting Procedures	5-1
Section III. Direct Support Maintenance Procedures	5-3
CHAPTER 6. GENERAL SUPPORT MAINTENANCE INSTRUCTIONS	6-1
Section I. Repair Parts, Special Tools; Test, Measurement, and Diagnostic Equipment, and Support Equipment	6-1
Section II. General Support Maintenance Procedures	6-1
APPENDIX A. REFERENCES	A-1
APPENDIX B. MAINTENANCE ALLOCATION CHART	B-1
Section I. Introduction	B-1
Section II. Maintenance Allocation Chart	B-5
Section III. Special Tool and Test Equipment Requirements	B-9
Section IV. Remarks	B-10

TABLE OF CONTENTS

	Page
APPENDIX C. COMPONENTS OF END ITEM AND BASIC ISSUE ITEMS LIST	C-1
Section I. Introduction	C-1
Section II. Components of End Item Table	C-2
Section III. Basic Issue Item Table	C-4
APPENDIX D. ADDITIONAL AUTHORIZATION LIST	D-1
Section I. Introduction	D-1
Section II. Additional Authorization List	D-2
APPENDIX E. EXPENDABLE/DURABLE SUPPLIES AND MATERIALS LIST	E-1
Section I. Introduction	E-1
Section II. Expendable/Durable Supplies and Materials List	E-2
APPENDIX F. ILLUSTRATED LIST OF MANUFACTURED PARTS	F-1
APPENDIX G. TORQUE LIMITS	G-1
ALPHABETICAL INDEX	Index-1

LIST OF ILLUSTRATIONS

Figure No.	Title	Page
1-1	Pump Unit, Centrifugal, Diesel Engine-Driven, Self-Priming, 65 GPM	1-0
1-2	Location of Major Components	1-3
2-1	Operator's Controls and Indicators	2-3
2-2	Operator PMCS Routing Diagram	2-8
2-3	Priming Pump	2-12
2-4	Refueling DED Pump Assembly	2-14
2-5	Starting and Operating the DED Pump Assembly	2-16
2-6	Decals and Instruction Plates	2-18
2-7	Cold Weather Starting Aid	2-21
3-1	Servicing Fuel Inlet Filter	3-5
3-2	Servicing Air Cleaner Element	3-6
4-1	Ident Plates Replacement	4-17
4-2	Roll-Over Frame Replacement	4-19
4-3	Compression Release Handle Replacement	4-21
4-4	Control Assembly Replacement	4-23
4-5	Air Intake Hose Replacement	4-25
4-6	Exhaust Extension Replacement	4-27
4-7	Access Cover Repair and Replacement	4-29
4-8	Pump Drain Repair and Replacement	4-31
4-9	Oil Drain Repair and Replacement	4-33
4-10	Baffles Replacement	4-35
4-11	Enclosure Assembly, Inlet Side Removal	4-39
4-12	Enclosure Assembly, Inlet Side Disassembly	4-40
4-13	Enclosure Assembly, Outlet Side Removal	4-43
4-14	Enclosure Assembly, Outlet Side Disassembly	4-44
4-15	Pump Inlet/Outlet Piping Repair and Suction Flange Repair and Replacement	4-47
4-16	Bottom Pan Frame Repair and Replacement.....	4-51
4-17	Pump Assembly Repair and Replacement	4-55
4-18	Measuring Impeller Clearance	4-57
4-19	Fuel Tank Assembly Repair and Replacement	4-61
4-20	Fuel Filter, Inlet Replacement	4-65
4-21	Fuel Cock and Fuel Filter, Outlet Replacement	4-67
4-22	Fuel Lines Replacement	4-69
4-23	Air Cleaner, Filter Element, and Air Intake Pipe Repair and Replacement	4-71
4-24	Exhaust Silencer Replacement	4-73
4-25	Recoil Starter and Fan Cooling Case Repair and Replacement	4-75
4-26	Fuel Injector Pump Replacement	4-79
4-27	Fuel Injector Pump Alignment	4-79
4-28	Lube Oil Strainer Repair and Replacement	4-81
4-29	Oil Cap/Gauge Repair and Replacement.....	4-83

LIST OF ILLUSTRATIONS

Figure No.	Title	Page
5-1	Mounting Plate Repair and Replacement	5-5
5-2	Fuel Injector Valve Assembly Replacement	5-7
5-3	Regulator Bracket Assembly Repair and Replacement	5-11
5-4	Cylinder Head Removal.....	5-15
5-5	Cylinder Head Disassembly.....	5-17
5-6	Valve Recess	5-18
5-7	Spring Inclination	5-18
5-8	Alignment of Flywheel With Cylinder Block	5-21
5-9	Adjusting Valve Clearance	5-21
5-10	Flywheel Replacement	5-23
6-1	Crankcase Cover Replacement	6-3
6-2	Main Bearing Insert Removal	6-4
6-3	Tightening Sequence for Crankcase Cover Bolts.....	6-5
6-4	Piston and Connecting Rod Assembly Replacement	6-7
6-5	Governor Assembly Removal	6-13
6-6	Lube Oil Pump Repair and Replacement.....	6-14
6-7	Lube Oil Pump Installation	6-14
6-8	Balancer Shaft Removal.....	6-17
6-9	Rotating Group Timing Marks.....	6-29
6-10	Camshaft Removal.....	6-19
6-11	Rotating Group Timing Marks.....	6-19
6-12	Crankshaft Assembly Replacement	6-21

LIST OF TABLES
Title

Figure No.

Page

1-1	Equipment Data	1-4
2-1	Preventive Maintenance Checks and Services	2-6
3-1	Operator Troubleshooting	3-2
4-1	Unit Preventive Maintenance Checks and Services.....	4-6
4-2	Troubleshooting by Exhaust Color	4-9
4-3	Unit Troubleshooting	4-11
5-1	Direct Support Troubleshooting Chart	5-2

HOW TO USE THIS MANUAL

GENERAL. This technical manual provides you with the information needed to operate and to maintain the DED Pump Assembly. By properly using this manual, you will be able to identify any problem you may have in operating the pump assembly and then locate the proper procedure needed to correct any problem found.

MANUAL ORGANIZATION. This manual has been organized in a manner that groups together the information that an operator or a maintenance technician will need to perform their duties. The following list indicates how this information has been organized.

- Chapter 1** This chapter contains a complete description of the pump assembly and includes such information as general equipment data, location/descriptions of major pump assembly components, and general theory of operations for the pump assembly.
- Chapter 2** The information needed to set up and to operate the pump assembly are included in this chapter. It includes assembly information, operator PMCS, and special instructions for unusual or emergency conditions.
- Chapter 3** All operator maintenance procedures have been placed within this chapter.
- Chapter 4** In the event that unit level maintenance is required for the pump assembly, the required maintenance instructions can be found in this chapter.
- Chapter 5** The required maintenance instructions authorized for direct support level maintenance can be found in this chapter.
- Chapter 6** This chapter contains the maintenance procedures for general support maintenance personnel.
- Appendix A** Some of the procedures in this manual have references to other military technical manuals and forms. A complete list of all of these Reference Documents is included in this appendix.
- Appendix B** This appendix contains the Maintenance Allocation Chart for the pump assembly. This chart defines which of the items on the pump assembly will likely require maintenance and what military maintenance level is authorized to perform these maintenance procedures.
- Appendix C** The Components of End Item List containing a complete listing of all of the items required for a complete pump assembly and the Basic Issue Items List showing the essential items needed to operate the pump assembly are contained in this appendix.

- Appendix D** If any additional items are authorized for support of the pump assembly, they will be shown on the Additional Authorization List contained in this appendix.
- Appendix E** As you operate and maintain the pump assembly you will be required to use some special expendable items. The Expendable/Durable Supplies and Materials List in this appendix is a complete list of these items which appear elsewhere in the operating and maintenance procedures in this manual.
- Appendix F** Some components of the pump assembly must be manufactured from bulk or stock material before they can be replaced on the unit. A complete set of instructions required to manufacture these items from bulk stock is included in this Illustrated List of Manufactured Parts.
- Appendix G** It is very important to properly tighten all fasteners used in the pump assembly to insure proper operation of the pump assembly and to protect operating personnel. To assist you in properly tightening these fasteners, this appendix contains the standard Torque Limits for the fasteners used on the pump assembly.

AIDS TO FINDING INFORMATION. The following aids have been placed within this technical manual to help you quickly locate the information you may need.

- Front Cover Index** To provide you with a quick reference to the most used portions of this manual, an index has been placed on the cover of this manual.
- Bleeder Edges On Pages** On the right edge of the front cover index of this manual you will see a black box area that goes to the edge of the front cover page. If you hold this manual with you left hand and bend back the outer right edges of the pages with your right hand, you will find that there are pages inside the technical manual that also have black boxes on the right edges of the page and that these boxes line up with the boxes on the front cover index. By turning to the page in the technical manual that lines up with the box on the front cover, you will be able to quickly turn to the topic shown in the front cover index.
- Table Of CONTENTS AND Boxed Titles** In the event that the front cover has been removed from this manual, the items that appear in the front cover index have also been placed in a box where they appear in the Table of Contents of this manual.

**Alphabetical
Index**

To assist you in locating any other information not found in the front cover index or the Table of Contents, an alphabetical index has been placed in the back of this manual to help you find any information you may need.

GENERAL MAINTENANCE METHOD. Although your local standard operating and maintenance procedure may vary, a simple method of using this technical manual to operate and maintain the pump assembly is shown in the following steps.

**WARNINGS And CAUTIONS.
Always Read, Understand, and Perform ALL WARNINGS and CAUTIONS
Found In This Technical Manual BEFORE Performing
The Step Immediately Following The
WARNING or CAUTION.**

Throughout this technical manual there are certain procedures and operations that are hazardous to you or to the pump assembly. If you see a **WARNING**, pay special attention to the information stated in it because all WARNINGS provide you with data that will prevent serious injury to you or others around you. When you see a **CAUTION** read it carefully because the information given in it will keep you from damaging the pump assembly and making the pump assembly unable to fulfill its mission.

Equipment Set Up And Operation. Unpack and set up the pump assembly in accordance with the procedures shown in Chapter 2.

Preventive Maintenance Checks And Services (PMCS). Perform the operator PMCS procedures shown in Chapter 2.

Troubleshooting Procedures. If the pump assembly should not operate properly, refer to either the operating troubleshooting procedures in Chapter 3, the unit troubleshooting procedures in Chapter 4, or the direct support troubleshooting procedures in Chapter 5. The most likely pump assembly malfunctions have been placed within these troubleshooting procedures and a test and/or repair procedure paragraph has been indicated to correct the malfunction found. If a repair is required, refer to the maintenance paragraph shown in the troubleshooting procedure.

Maintenance Procedures. The complete repair procedures needed to correct a problem found with the pump assembly have been included in Chapters 3, 4, 5, and 6.

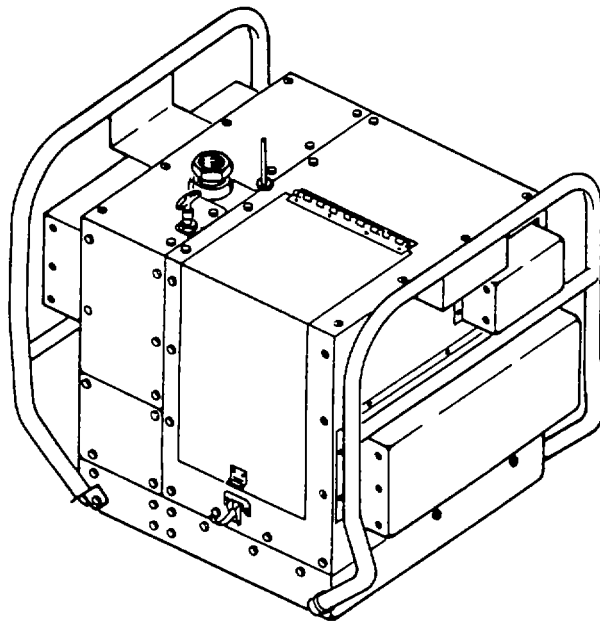
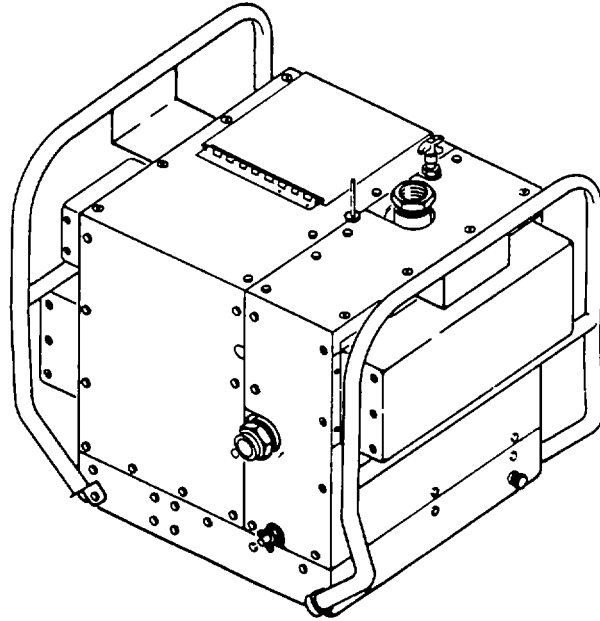

**Figure 1-1. Pump Unit, Centrifugal, Diesel Engine Driven,
Self-Priming, 65 GPM.**

CHAPTER 1

INTRODUCTION

SECTION I. GENERAL INFORMATION

1-1. SCOPE.

- a. Type of Manual. Operator's, Unit, Direct Support, and General Support Maintenance Manual
- b. Model Number and Equipment Name. Model 4M SDQ 2000 Pump Unit, Centrifugal, Diesel Engine Driven (DED), Self-Priming, 65 GPM.
- c. Purpose of Equipment. The pump unit covered by this manual is intended for use in pumping water to and from various water storage and distribution systems.

1-2. MAINTENANCE FORMS AND PROCEDURES. Department of the Army forms and procedures used for equipment maintenance will be those prescribed by DA PAM 738-750. The Army Maintenance Management System (TAMMS) (Maintenance Management UPDATE).

1-3. CORROSION AND PREVENTION CONTROL. Corrosion Prevention and Control (CPC) of Army materiel is a continuing concern. It is important that any corrosion problems with this item be reported so that the problem can be corrected and improvements can be made to prevent the problem in future items.

While corrosion is typically associated with the rusting of metals, it can also include deterioration of other materials such as rubber and plastic. Unusual cracking, softening, swelling, or breaking of the materials may be a corrosion problem.

If a corrosion problem is identified, it can be reported using Standard Form 368, Product Quality Deficiency Report. Use of key words such as "rust", "deterioration", "corrosion", or "cracking" will insure that the information is identified as a CPC problem. The form should be submitted to the address specified in the DA PAM 738-750.

1-4. DESTRUCTION OF ARMY MATERIEL TO PREVENT ENEMY USE. Refer to TM 750-244-3, Procedures for Destruction of Equipment to Prevent Enemy Use.

1-5. PREPARATION FOR STORAGE OR SHIPMENT. Contact unit maintenance for preparation and storage or shipment. Refer to Section VI, Chapter 4.

1-6. REPORTING EQUIPMENT IMPROVEMENT RECOMMENDATIONS (EIR'S). If your pump assembly needs improvement, let us know. Send us an EIR. You, the user, are the only one who can tell us what you don't like about your equipment. Let us know why you don't like the design or performance. Put it on a SF 368 (Product Quality Deficiency Report). Mail it to us at;

Commander
U.S. Army Aviation and Troop Support Command
Attention: AMSAT-I-MDO
4300 Goodfellow Blvd.
St. Louis, Missouri 63120-1798.

We will send you a reply.

1-7. **NOMENCLATURE CROSS-REFERENCE LIST.** To simplify the use of certain terms used in this technical manual, some common names have been used to replace longer or more complex terms. The following list shows the common name used in this technical manual and the official nomenclature of the terms these common names replace.

<u>Common Name</u>	<u>Official Nomenclature</u>
DED pump assembly or pump assembly	Pump Unit, Centrifugal, Diesel Engine Driven, Self-Priming, 65 GPM Water

1-8. **LIST OF ABBREVIATIONS.** All abbreviations use within this technical manual conform to the standard military abbreviations found in MIL-STD-12, Abbreviations for Use on Drawings, and in Specifications, Standards, and Technical Documents.

SECTION II. EQUIPMENT DESCRIPTION

1-9. EQUIPMENT CHARACTERISTICS, CAPABILITIES, AND FEATURES.

a. Characteristics and Capabilities. The 'DED pump assembly is designed to pump water and has the following characteristics and capabilities.

- (1) Self contained diesel engine driven unit.
- (2) The pump and engine assembly are enclosed within an enclosure assembly which has been specially designed to reduce the amount of noise emitted from the DED pump assembly during pumping operations.
- (3) The DED pump assembly is capable of pumping 65 gallons per minute of water at not more than a 50 foot head and not more than a 10 foot static suction lift.

b. Features. The DED pump assembly has the following features.

- (1) The diesel engine is equipped with a manual recoil type starter.
- (2) The enclosure assembly is equipped with a roll-over frame mounted onto the enclosure to provide an easier and more stable way of manually moving the DED pump assembly to various operating sites. These handles also act as a roll cage to protect the unit in the event the unit should roll over.
- (3) A throttle control on the engine allows for varying the speed of the engine to control the pumping rate of the DED pump assembly.
- (4) After the pump has been initially primed, it is capable of being stopped and restarted without the need of further priming.

1-10. **LOCATION AND DESCRIPTION OF MAJOR COMPONENTS.** The following major components of the DED pump assembly are described below and are located as shown on Figure 1-2.

a. Diesel Engine Assembly. A 3. 8 horsepower diesel engine (1) is provided to drive the pump.

b. Pump. A self-priming pump (2) is attached to the diesel engine assembly. This centrifugal type pump uses an impeller to provide the pumping capability of the DED pump assembly.

c. **Bottom Pan Frame.** All of the above items are mounted and assembled to a lower bottom pan frame (4). This bottom pan frame is equipped with a roll-over frame (5) to allow easier movement of the DED pump assembly to other locations.

d. **Sound Enclosure Assembly.** Because the normal operation of the diesel engine can be quite noisy, a sound enclosure (3) surrounds the pump and diesel engine to reduce the amount of noise transmitted to the operator. This enclosure is equipped with an operator access door for use in starting, operating, and servicing of the unit.

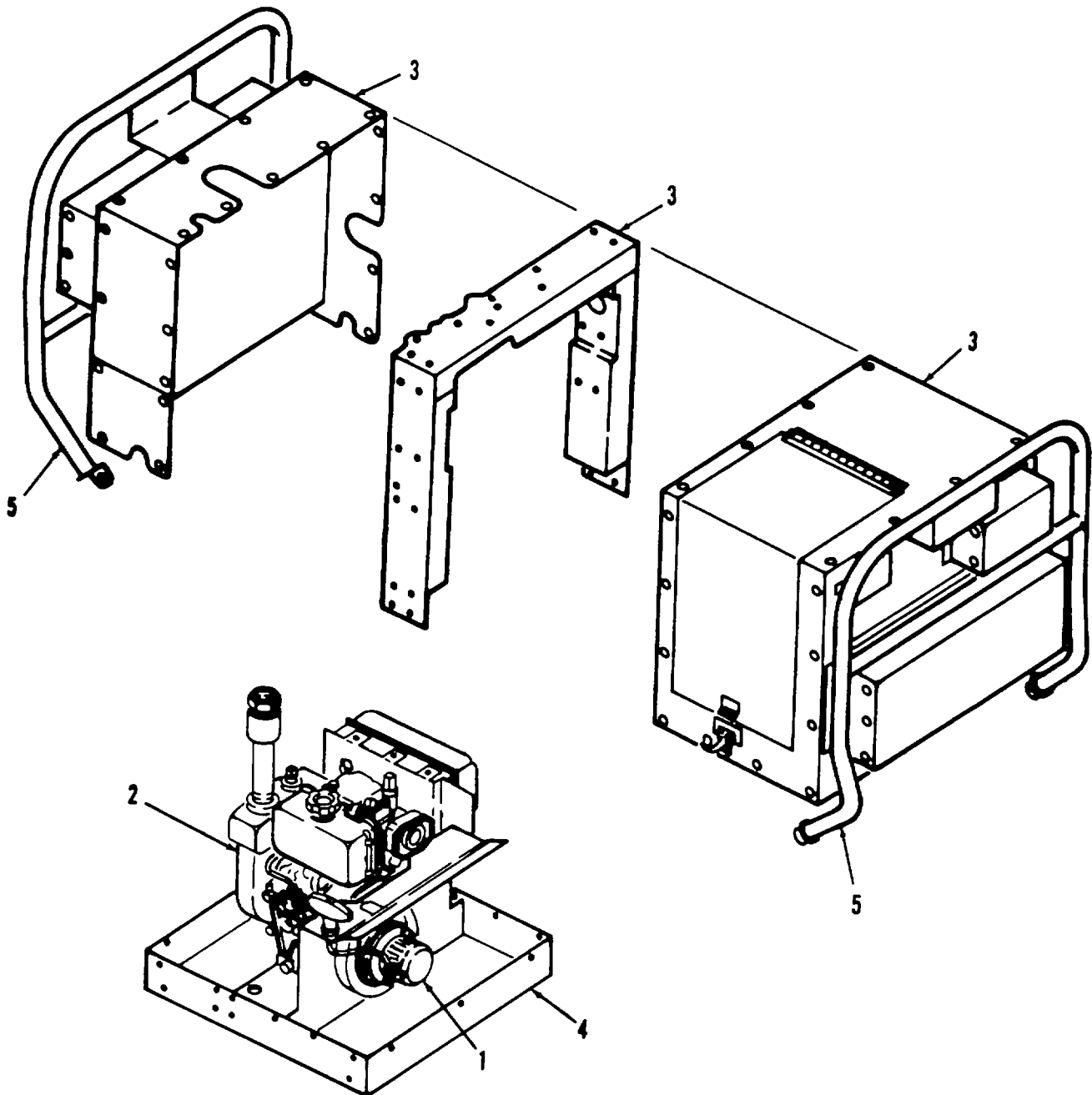

Figure 1-2. Location of Motor Components.

1-11. EQUIPMENT DATA. Refer to Table 1-1. for general equipment and performance data for the DED pump assembly.

Table 1-1. Equipment Data.

PUMP

Manufacturer	E. C. Schleyer Pump Company, Inc.
Service	Water
Duty Cycle	Continuous
Rated Output	65 GPM at 50 ft total head
Suction (Intake) Port	1.50 in. NPT
Discharge Port	1.50 in. NPT
Priming Method	Self-priming after initial filling
Drain Port	3/8 in. NPT
Rotation	Counterclockwise (facing pump side)

ENGINE

Manufacturer	Yanmar
Model	L40AE-D
Horsepower	3.8
Type	Four-stroke, forced air cooled by flywheel fan
Number of Cylinders	One
Bore	2.677 in. (68 mm)
Stroke	2.165 in. (55 mm)
Displacement	12.14 cu in. (0.199 liter)
Compression Ratio (nominal)	20.5 to 1
Direction of Rotation	Counterclockwise (facing shaft end)
Number of Main Bearings	Two

AIR CLEANER

Manufacturer	Yanmar
Type	Dry type, paper cleaner element

CAPACITIES

Fuel Tank	0.92 gallon (3.5 liters)
Engine Crankcase	0.79 quart (0.75 liter)

DIMENSIONS AND WEIGHT

Overall Width	27.37 in (69.5 cm)
Overall Length	23.94 in (60.8 cm)
Overall Height	24.33 in (61.8 cm)
Gross Weight	202.00 lb (91.82 kg)
Shipping Volume	9.2 cubic feet (0.26 cubic meter)

SECTION III. PRINCIPLES OF OPERATION

1-12. THEORY OF OPERATIONS. The DED pump assembly is a self contained, transportable, diesel engine driven centrifugal pump unit designed for pumping water. It consists of a self-priming pump, a four stroke air cooled diesel engine, and a sound enclosure for noise reduction. The pump assembly performs its pumping operations in the following manner (Refer to Figure 1-2).

a. **Pumping Capability.** The pumping capability of the DED pump assembly is provided by the pump unit contained within the assembly. This pump is a centrifugal type pump which means that it provides its pumping action by using an internal rotating impeller to sling the water from the center of the impeller to the outer edges of the impeller as it rotates. This throwing action, technically known as centrifugal force, causes a vacuum in the inlet pipe of the pump to draw more water into the pump. The water which has been forced to the outer edges of the impeller are further forced into the outlet pipe of the pump to eventually leave the pump unit.

b. **Diesel Engine.** To cause the impeller inside the pump to rotate, the impeller shaft is connected to the output shaft of a diesel engine. This diesel engine is equipped with a manual recoil starter for starting the engine and a throttle control assembly to control the engine speed. When the maximum rated capacity of 65 GPM is required of the pump assembly, this throttle control is set to maximum to cause the engine to rotate at maximum rpm. When a pumping rate less than 65 GPM is required of the pump assembly, the diesel engine throttle control is adjusted to reduce the engine rpm until the lower rate of water to be pumped by the unit is achieved.

**CHAPTER 2
OPERATING INSTRUCTIONS**

CHAPTER 2 INDEX

Section I. Description and Use of Operator's Controls and Indicators	2-2
2-1. Introduction	2-2
2-2. Operator's Controls and Indicators	2-2
Section II. Operator Preventive Maintenance Checks and Services (PMCS)	2-4
2-3. General	2-4
2-4. PMCS Procedures	2-4
2-5. Special Instructions	2-5
2-6. Leakage Definitions for Operator PMCS	2-5
Section III. Operation Under Usual Conditions	2-12
2-7. Assembly and Preparation for Use	2-12
2-8. Initial Adjustments, Daily Checks, and Self Tests.....	2-15
2-9. Operating Procedures	2-15
2-10. Preparation for Movement	2-18
2-11. Decals and Instruction Plates.....	2-18
Section IV. Operation Under Unusual Conditions	2-20
2-12. Operation Under Unusual Weather	2-20
a. Operation In Extreme Cold	2-20
b. Operation In Extreme Heat	2-21
c. Operation In Sandy or Dusty Areas	2-21
d. Operation In Salt Water Areas	2-22
2-13. Emergency Procedures	2-22
2-14. Nuclear, Biological, and Chemical (NBC) Decontamination Procedures.....	2-22

SECTION I. DESCRIPTION AND USE OF OPERATOR'S CONTROLS AND INDICATORS

2-1. INTRODUCTION. The DED pump assembly is designed for operation in a wide range of climatic conditions. Operators must be aware of any peculiarities or operational limitations for their specific installation. Before setting up and operating this system, be sure that you have determined the type of terrain and climate in which you will use the unit and that you have assembled and serviced the system to match the existing needs.

2-2. OPERATOR'S CONTROLS AND INDICATORS. For controls and indicators applicable to the DED pump assembly, refer to the following descriptions and to Figure 2-1.

a. Cold Weather Plug (1). During DED pump assembly operation in colder weather, engine starting can be further helped by removing the cold weather plug on the top of the engine rocker arm cover and adding 5 or 6 drops of engine oil. This reduces the additional friction caused by colder weather and makes the engine easier to start.

b. Decompression Handle (2). Because of the high internal cylinder pressure inside a diesel engine, it can be difficult to start manually since the operator must overcome this internal pressure to start the engine rotation. To relieve this internal cylinder pressure for starting purposes, an engine decompression handle is furnished to vent the cylinder pressure and allow for easier engine starting.

c. Diesel Engine Throttle Control (3). After the diesel engine has been started, the engine speed can be controlled by setting the engine throttle control.

d. Engine Oil Dipstick (4). To provide a method of checking for the correct amount of oil in the diesel engine, the engine is equipped with an engine oil dipstick. By removing this dipstick and checking the indicated oil level, proper engine oil may be added as needed. Engine oil is added through the engine oil dipstick opening in the engine crankcase.

e. Fuel Cock (5). To control the flow of fuel from the fuel tank to the engine, a fuel cock is included to turn the fuel flow off or on.

f. Fuel Gauge Pipe (6). The amount of fuel in the engine fuel tank is shown in a fuel gauge pipe located on the side of the fuel tank.

g. Lube Oil Drain Plug (7). At certain intervals and conditions, the engine oil must be drained and replaced with new engine oil. To remove the existing oil from the engine, a lube oil drain plug is provided on the DED pump assembly skid.

h. Manual Recoil Starter (8). The diesel engine is started by use of the manual recoil starter located on the side of the engine. After pulling the handle out firmly and quickly, the engine will start.

i. Pump Drain Cock (9). In the event that the DED pump assembly must be stored or will not be used for an extended period of time, a pump drain plug on the DED pump assembly skid is provided to drain water from the pump body to keep freezing water from damaging the pump.

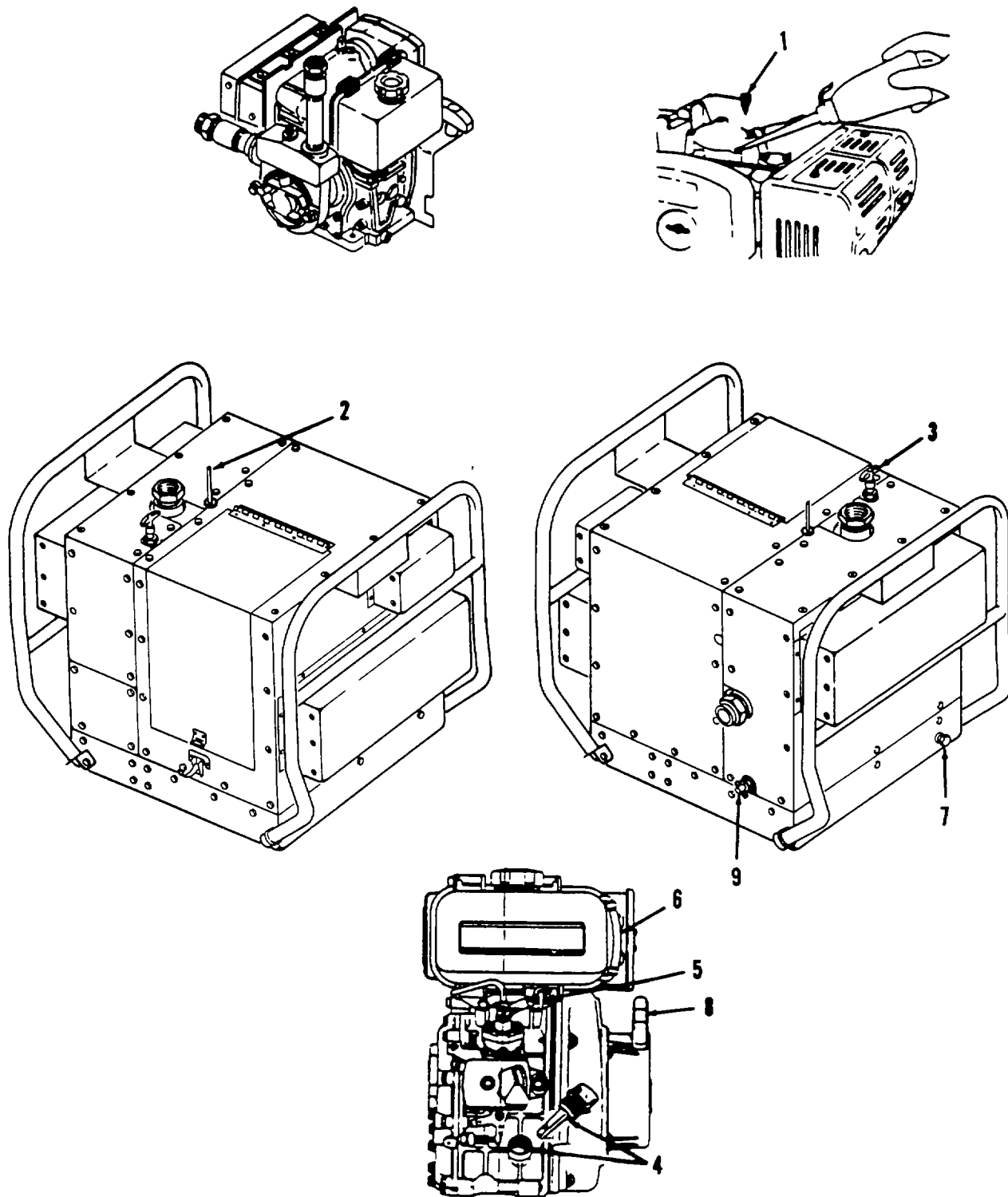

Figure 2-1. Operator's Controls and Indicators.

SECTION II. OPERATOR PREVENTIVE MAINTENANCE CHECKS AND SERVICES (PMCS)

2-3. GENERAL. Preventive Maintenance Checks and Services (PMCS) means systematic caring, inspecting, and servicing of equipment to keep it in good condition and to prevent breakdowns. As the operator of the DED Pump Assembly, your mission is to:

- a. Be sure to perform your PMCS each time you operate your DED pump assembly. Always do your PMCS in the same order, so it gets to be a habit. Once you've had some practice, you'll quickly spot anything wrong.
- b. Do your **BEFORE (B)** PMCS just before you operate the DED pump assembly. Pay special attention to all WARNINGS, CAUTIONS, and NOTES.
- c. Do your **DURING (D)** PMCS while you are operating the DED pump assembly. During operations means to monitor the DED pump assembly and its related components while it is actually being operated. Pay special attention all WARNINGS, CAUTIONS, and NOTES.
- d. Do your **AFTER (A)** PMCS right after you have operated the DED pump assembly. Pay special attention to all WARNINGS, CAUTIONS, and NOTES.
- e. Do your **WEEKLY PMCS** once a week.
- f. Do you **MONTHLY PMCS** once a month.
- g. Use DA Form 2404 (Equipment Inspection and Maintenance Worksheet) to record any faults that you discover before, during, or after operation unless you can fix them. You do not need to record faults that you fix.
- h. Be prepared to assist unit maintenance in any lubrication procedures. Perform any other services when required by unit maintenance.

2-4. PMCS PROCEDURES.

- a. Your Preventive Maintenance Checks and Services, Table 2-1, lists inspections and care to keep your DED pump assembly in good operating condition. It is set up so you can make your BEFORE (B) Operation checks as you perform a general examination of the DED pump assembly.
- b. The "INTERVAL" column of Table 2-1 tells you when to do a certain check or service.
- c. The "PROCEDURE" column of Table 2-1 tells you how to do required checks and services. Carefully follow these instructions. If you do not have tools or if the procedure tells you to, notify your supervisor.

NOTE

Terms "ready/available" and "mission capable" refer to the same status: Equipment is on hand and ready to perform combat missions. (See DA PAM 738-750.)

- d. The "NOT FULLY MISSION CAPABLE IF:" column in Table 2-1 tells you when your DED pump assembly is not capable and why the DED pump assembly cannot be used.

e. If the DED pump assembly does not perform as required, refer to Section III, Operator Troubleshooting.

f. If anything looks wrong and you can't fix it, write it on your DA Form 2404 IMMEDIATELY and report it to your supervisor.

g. When you do your PMCS, you will always need a rag or two. The following items are common to all of the DED pump assembly components:

(1) Keep It Clean. Dirt, grease, oil, and debris only get in the way and may cover up a serious problem. Clean as you work and as needed. Use dry cleaning solvent (Appendix E, Item 3) on all metal surfaces. Use soap (Appendix E, Item 10) when you clean rubber or plastic material.

(2) Rust and Corrosion. Check the components of the DED pump assembly for rust and corrosion. If any bare metal or corrosion exists, clean and apply a thin coat of oil. Report it to your supervisor.

(3) Bolts, Nuts, and Screws. Check them for obvious looseness, missing, bent, or broken condition. You can't try them all with a tool, but look for chipped paint, bare metal, or rust around bolt heads. If you find a bolt, nut, or screw you think is loose, tighten it or report it to your supervisor.

(4) Welds. Look for loose or chipped paint, rust, or gaps where metal parts are welded together. If you find a bad weld, report it to your supervisor.

(5) Hoses. Look for wear, damage, or leaks and make sure clamps and fittings are tight. Wet spots show obvious leaks, but a stain around a fitting or connector can also mean a leak. If a leak comes from a loose fitting or connector, tighten it. If something is broken or worn out, report it to your supervisor.

h. When you check for "proper operating condition", you look at the component to see if its serviceable.

2-5. SPECIAL INSTRUCTIONS. If the equipment must be kept in continuous operation, check and service only those items that can be checked and serviced without disturbing operation. Make the complete checks and services when the equipment can be shut down.

2-6. LEAKAGE DEFINITIONS FOR OPERATOR PMCS. It is necessary for you to know how fluid leakage affects the status of the DED pump assembly. Following are types and classes of leakage an operator needs to know to be able to determine the status of the DED pump assembly. Learn these leakage definitions and remember -- **when in doubt, notify your supervisor.**

CAUTION

- Equipment operation is allowable with minor leakages (Class I or II). Of course, consideration must be given to fluid capacity in the item/system being checked/inspected. When in doubt, notify your supervisor.
- When operating with Class I or II leaks, continue to check fluid levels as required by your PMCS.
- Class III leaks should be reported immediately to you supervisor.

2-6. LEAKAGE DEFINITIONS FOR OPERATOR PMCS. - Continued.

a. CLASS I. Seepage of fluid (as indicated by wetness or discolorization) not great enough to form drops.

b. CLASS II. Leakage of fluid great enough to form drops, but not enough to cause drops to drip from item being checked/inspected.

c. CLASS III. Leakage of fluid great enough to form drops that fall from item being checked/inspected.

Table 2-1. Operator Preventive Maintenance Checks and Services For DED Pump Assembly. (Refer to Figure 2-2.)

Item No.	Interval	Location	Procedure	Not Fully Mission Capable If:
		Item To Check/Service.		
1	Before	ENCLOSURE ASSEMBLY	<p>a. Inspect enclosure assembly for damage and readability. Check for loose or missing mounting hardware</p> <p>b. Inspect roll-over frame for bends or cracks. Check for loose or missing mounting hardware.</p> <p>c. Inspect access cover for damage. Check for loose or missing mounting hardware.</p> <p>d. Inspect all engine labels readability. Check all visible engine gaskets for leaks.</p>	<p>Mounting hardware is loose or missing.</p> <p>Access cover is damaged. Mounting hardware is loose or missing.</p>
2	Before	COMPRESSION RELEASE HANDLE	Inspect handle for damage. Push compression release handle in and then pull it out. Insure the handle operates smoothly and does not bind.	Handle is damaged or binds.
3	Before	THROTTLE CONTROL HANDLE	Inspect handle for damage and for smoothness of operation.	Handle is damaged or does not operate smoothly.
4	Before	AIR INTAKE HOSE	Inspect that air intake hose is connected and for damage.	Air intake hose is disconnected or damaged

Table 2-1. Operator Preventive Maintenance Checks and Services for DED Pump Assembly.

Item No.	Interval	Location Item To Check/Service.	Procedure	Not Fully Mission Capable If:
5	Before	EXHAUST EXTENSION		Exhaust extension is clogged.
6	Before	PUMP DRAIN	Inspect exhaust extension for excessive corrosion. Check for clogging.	Drain cock is damaged. Pipe is cracked or leaks.
7	Before	OIL DRAIN	Inspect for missing oil drain plug. Check for loose or leaking hose or fittings.	Oil drain plug is missing. Hose or fittings have a Class III leak.
8	Before Mounting hardware is loose or missing.	BAFFLES	Inspect baffles for damage. Check for loose or missing mounting hardware.	Baffles are damaged. Mounting hardware is loose or missing.
9	Before	ENCLOSURE ASSEMBLY, INLET SIDE AIR	Inspect enclosure for damage. Check for loose or missing mounting hardware. Inspect access door for damage. Check interior of enclosure for debris. Check insulation for damage.	Enclosure is damaged. Mounting hardware is loose or missing. Access door is damaged.
10	Before	ENCLOSURE ASSEMBLY, OUTLET SIDE AIR	Inspect enclosure for damage. Check for loose or missing mounting hardware. Check interior of enclosure for debris. Check insulation for damage.	Enclosure is damaged. Mounting hardware is loose or missing.
11	Before	PUMP INLET / OUTLET PIPING	Inspect piping for cracks. Check pipe threads for damage. Check for debris in pipes. Inspect for missing or damaged outlet pipe gaskets.	Pipes are cracked. Pipe threads are damaged. Pipes have debris in them.
12	Before	MOUNTING PLATE	Inspect mounting plate for cracks. Check for loose or missing mounting hardware.	Mounting hardware is loose or missing.
13	Before	BOTTOM FRAME PAN	Inspect for damage to frame. Check for damaged or missing bumper feet. Check for loose or missing attaching hardware.	Attaching hardware is loose or missing.

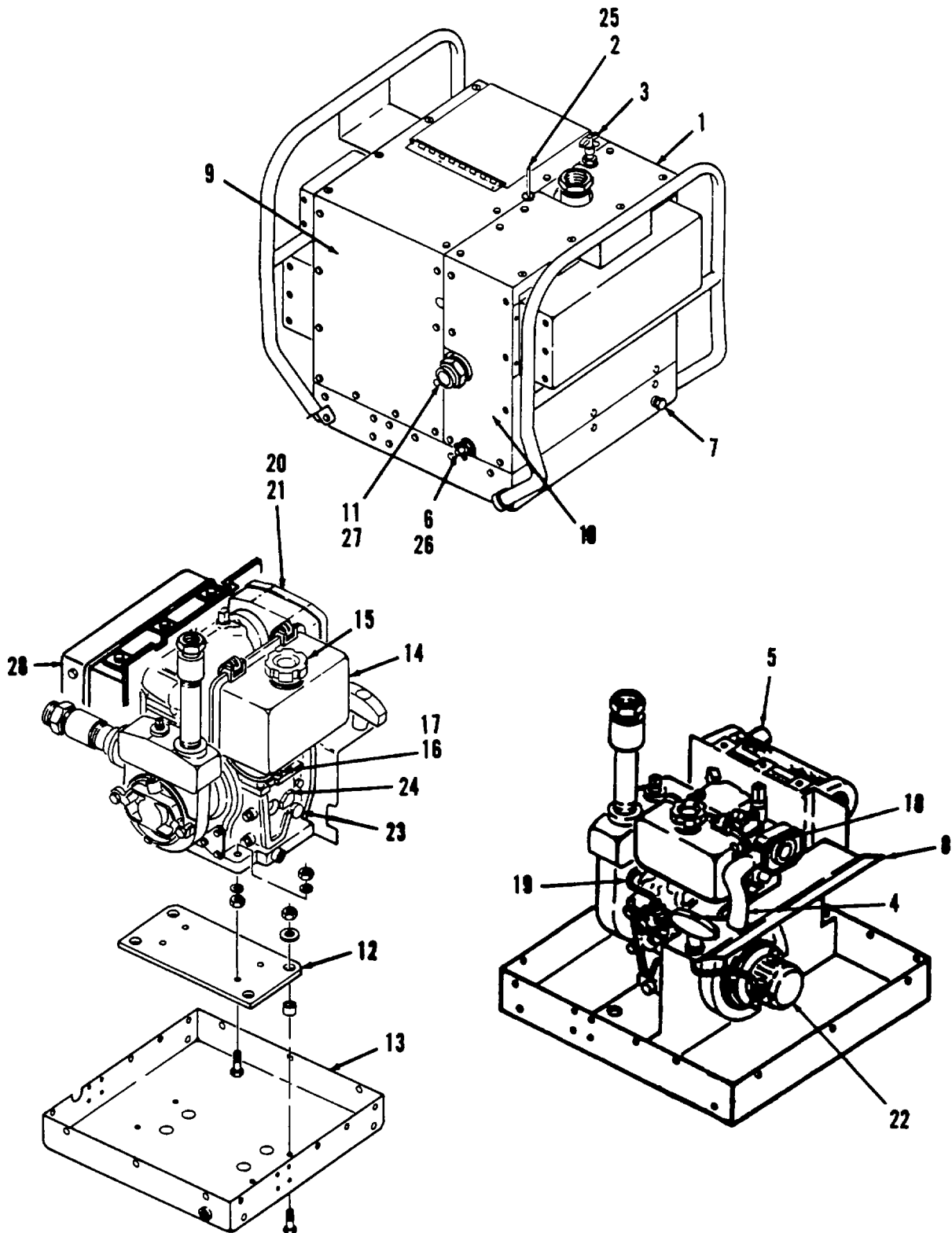

Figure 2-2. Operator PMCS Routing Diagram.

Table 2-1. Operator Preventive Maintenance Checks and Services for DED Pump Assembly.

Item No.	Interval	Location	Procedure	Not Fully Mission Capable If:
		Item To Check/Service.		
14	Before	FUEL TANK ASSEMBLY	Inspect fuel tank for leaks. Check for missing cap. Check for loose or missing mounting hardware. Check fuel level (See para. 2-7).	Fuel tank leaks. Cap is missing. Mounting hardware is loose or missing.
15	Before	FUEL FILTER, INLET	Inspect for damaged or missing inlet fuel filter. Check filter for debris and clogging.	Inlet fuel filter is missing. Filter is clogged with debris.
16	Before	FUEL COCK	Inspect for damaged or leaking fuel cock.	Fuel cock is damaged or leaking.
17	Before	FUEL FILTER, OUTLET	Remove fuel tank cap and check bottom of tank for missing fuel outlet filter.	Fuel outlet filter is missing.
18	Before	PIPE FUEL GAUGE	Inspect pipe fuel gauge for leaks. Check for loose or missing clamps.	Pipe fuel gauge leaks. Clamps are loose or missing.
19	Before	FUEL LINES	Inspect all fuel lines for damage or leaks. Check for loose or missing clamps.	Fuel lines leak. Clamps are loose or missing.
20	Before	AIR CLEANER	Inspect air cleaner housing for damage. Check for loose or missing mounting hardware.	Air cleaner housing is damaged. Mounting hardware is loose or missing.
21	Before	FILTER ELEMENT	Remove cover from air cleaner housing and inspect filter for clogging. Check gasket under air cleaner cover for damage.	Filter element is missing. Filter element is very dirty or clogged.
22	Before	RECOIL STARTER	Pull starter rope and check that recoil starter engages and rotates engine. Check that recoil starter retracts starter rope when starter rope handle is released.	Starter rope does not engage engine. Starter rope does not retract when released.

Table 2-1. Operator Preventive Maintenance Checks and Services for DED Pump Assembly - Continued.

Item No.	Interval	Location	Procedure	Not Fully Mission Capable If:
		Item To Check/Service.		
			<p>CAUTION</p> <p>Do not use more oil than specified as a starting agent or equipment damage could result. Too much oil could result in engine reversal. Should this occur, engine exhaust will be emitted from air intake. Stop engine at once. The oil pump in the engine does not work in reverse and severe engine damage could result.</p>	
23	Before	OIL CAP/ GAUGE	Inspect for missing or damaged oil cap/gauge. Check oil level. (See L0104320-316-12.)	Oil cap/gauge is missing or damaged. Oil level is incorrect.
24	Before	REGULATOR	<p>a. Check regulator bracket assembly for loose or missing hardware.</p> <p>b. Inspect for damaged or deformed springs.</p> <p>CAUTION</p> <ul style="list-style-type: none"> Do not stop engine suddenly since it may cause the temperature to get too high and cause possible damage to the engine. When stopping engine, reduce the load slowly and allow the engine to run at idle speed for 3 minutes before stopping engine. Do not stop engine with decompression lever as engine damage may result. If engine cannot be stopped by the throttle control handle, then move the fuel cock handle to the horizontal to close the cock and cut off fuel flow to the engine. 	Hardware is loose or missing. Springs are damaged or deformed.

**Table 2-1. Operator Preventive Maintenance Checks and Services
for DED Pump Assembly - Continued.**

Item No.	Interval	Location	Procedure	Not Fully Mission Capable If:
		Item To Check/Service.		
25	During	COMPRESSION RELEASE HANDLE	Check that handle is in up position while engine is operating.	
26	During	PUMP DRAIN	Check drain cock for leaks. Inspect pipe for leaks.	Pipe or drain cock has a Class III leak.
27	During	PUMP INLET / OUTLET PIPING	Inspect outlet piping for leaks.	Pipes leak during pumping operation.
28	During	EXHAUST SILENCER	Check for excessive noise or obvious exhaust gas leaks.	

SECTION III. OPERATION UNDER USUAL CONDITIONS

2-7. ASSEMBLY AND PREPARATION FOR USE. This paragraph show how to assemble the DED pump assembly and prepare it for use. The steps provided and the illustrations shown are for a typical pump set up. Always be sure that you follow your local standard operating procedures (SOP) first if there is a conflict between the steps shown here and you SOP.

a. Priming the Pump. Although the centrifugal pump used in the DED pump assembly is a self-priming pump, it is self-priming only after an initial prime is provided during its first start up. To initially prime the pump, perform the following steps. (Refer to Figure 2-3.)

- (1) Be sure that no hoses have been attached to either the inlet pipe (1) or the outlet pipe (2) of the DED pump assembly.
- (2) Fill the pump by pouring about one gallon of water through the outlet pipe (2) of the pump.

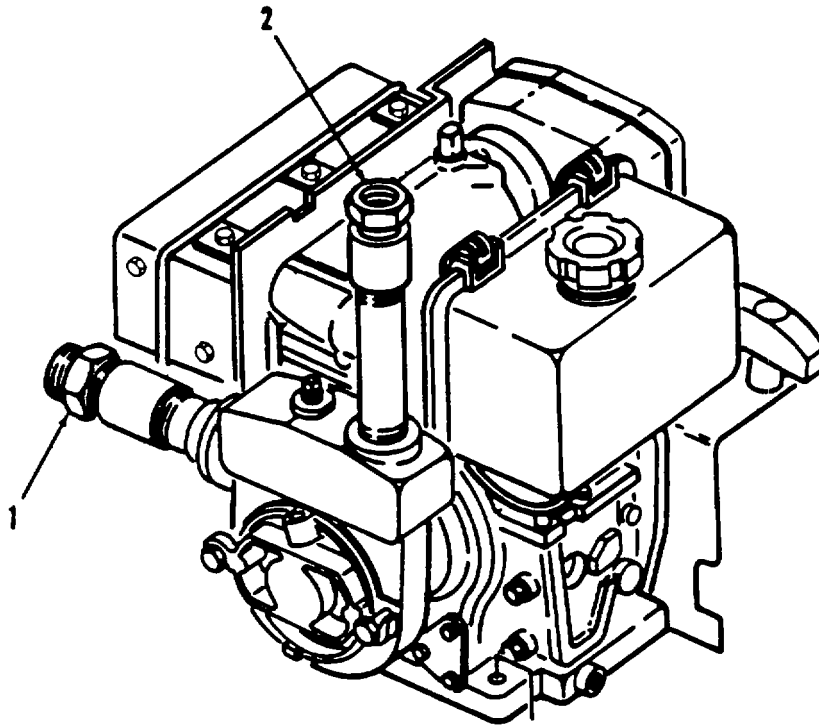

Figure 2-3. Priming Pump.

Table 2-1. Operator Preventive Maintenance Checks and Services for DED Pump Assembly - Continued.

Item No.	Interval	Location	Procedure	Not Fully Mission Capable If:
		Item To Check/Service.		
25	During	COMPRESSION RELEASE HANDLE	Check that handle is in up position while engine is operating.	
26	During	PUMP DRAIN	Check drain cock for leaks. Inspect pipe for leaks.	Pipe or drain cock has a Class III leak.
27	During	PUMP INLET / OUTLET PIPING	Inspect outlet piping for leaks.	Pipes leak during pumping operation.
28	During	EXHAUST SILENCER	Check for excessive noise or obvious exhaust gas leaks.	

SECTION III. OPERATION UNDER USUAL CONDITIONS

2-7. ASSEMBLY AND PREPARATION FOR USE. This paragraph show how to assemble the DED pump assembly and prepare it for use. The steps provided and the illustrations shown are for a typical pump set up. Always be sure that you follow your local standard operating procedures (SOP) first if there is a conflict between the steps shown here and you SOP.

a. Priming the Pump. Although the centrifugal pump used in the DED pump assembly is a self- priming pump, it is self-priming only after an initial prime is provided during its first start up. To initially prime the pump, perform the following steps. (Refer to Figure 2-3.)

- (1) Be sure that no hoses have been attached to either the inlet pipe (1) or the outlet pipe (2) of the DED pump assembly.
- (2) Fill the pump by pouring about one gallon of water through the outlet pipe (2) of the pump.

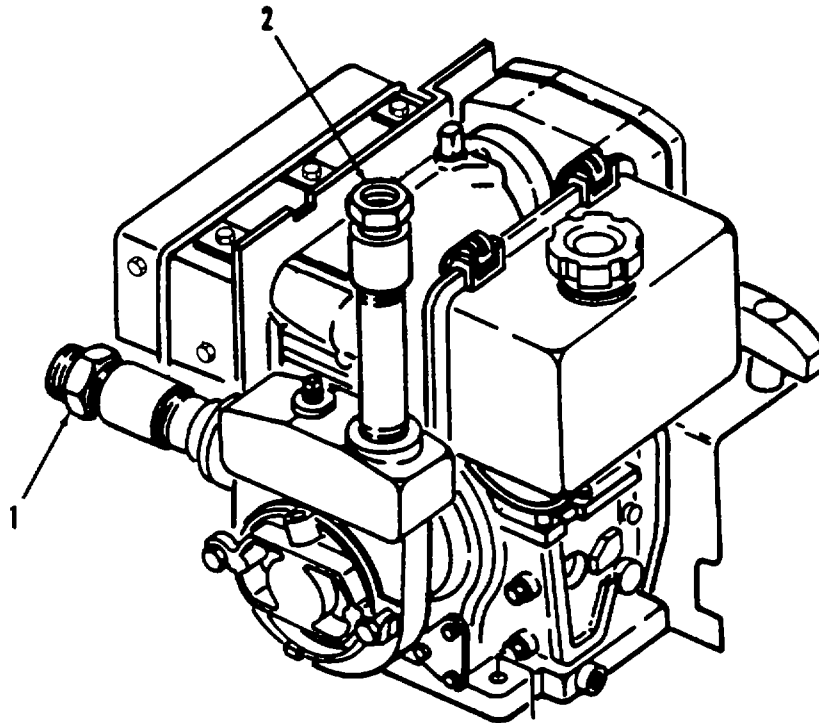

Figure 2-3. Priming Pump.

b. Filling the Fuel Tank. Before starting the DED pump assembly, the fuel tank must be filled with fuel. To fill the fuel tank, perform the following procedures. (Refer to Figure 2-4.)

(1) Disengage the latch (1) on the access panel (2) of the enclosure assembly (3) and open access cover.

(2) Check the pipe fuel gauge (4) on the side of the fuel tank (5) to insure that fuel tank is filled with fuel. If fuel tank is not full, perform steps (3) through (6) to fill the tank.

WARNING

Improper care in handling fuel can cause fire and explosion which can cause severe injury or death to operating personnel. To avoid fire or explosion during engine refueling:

- DO NOT allow any flame producing material within 50 feet (15.25 m) of fuel during equipment filling.
- DO NOT smoke while refueling.
- DO NOT let fuel drip onto any hot surface.
- DO NOT overfill fuel tank.
- DO NOT refuel unit while engine is running.

(3) Remove fuel tank cap (6).

(4) Check the inlet fuel filter (7) inside the top of the fuel tank (5) and carefully remove any debris that may have collected inside the filter.

(5) Carefully pour fuel from the fuel container into the fuel tank (5) while checking the pipe fuel gauge (4) on the side of the fuel tank. When the pipe fuel gauge indicates that the tank is full, stop filling the fuel tank.

(6) Replace fuel tank cap (6) onto fuel tank (5).

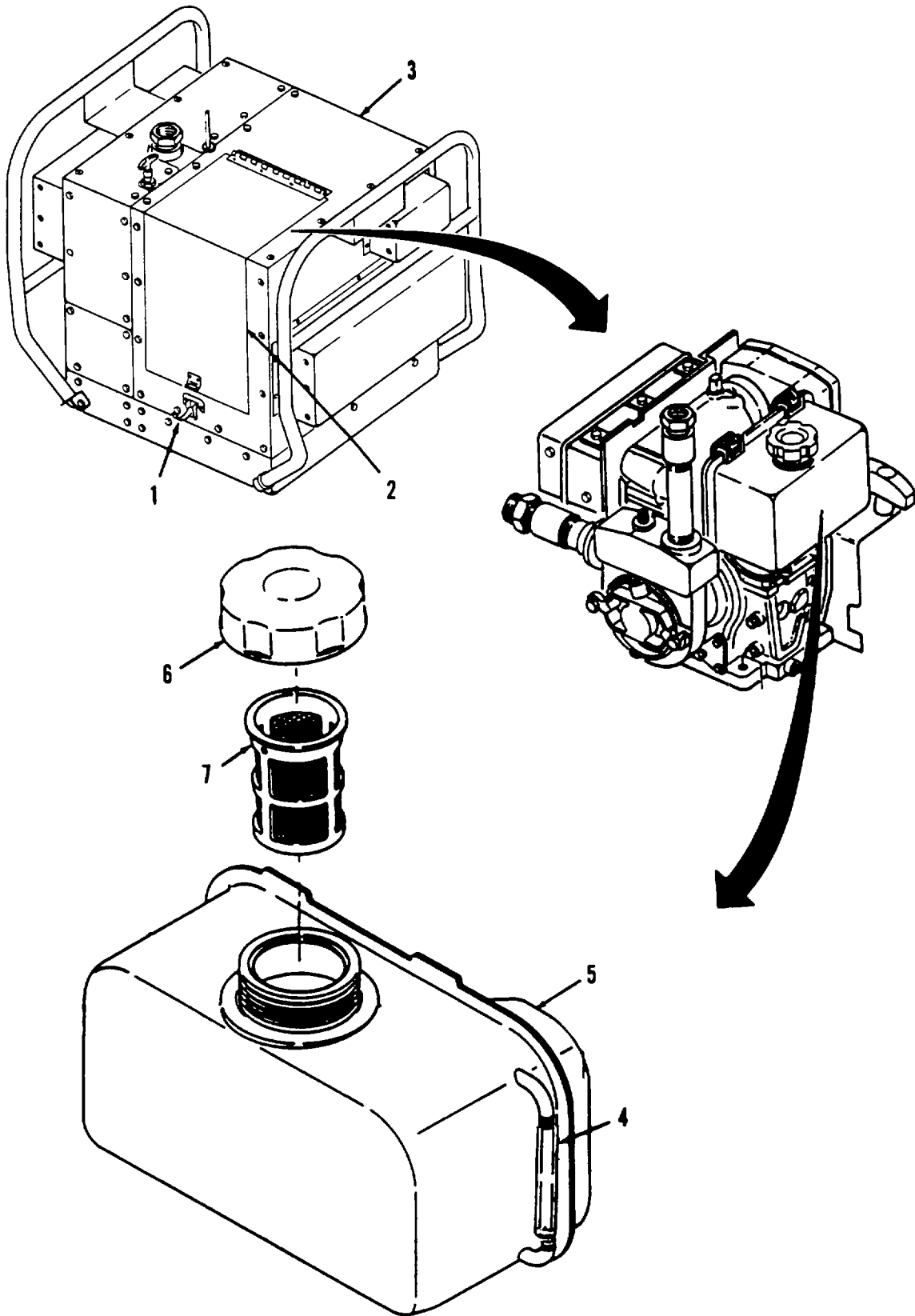

Figure 2-4. Refueling DED Pump Assembly.

c. Assembly for Use. The DED pump assembly itself does not require any assembly. However, it must be properly connected to a water system before operation. To connect the DED pump assembly into your water system, perform the following steps. (Refer to Figure 2-3.)

(1) Connect discharge hose to outlet pipe (2) of the DED pump assembly.

(2) Connect one end suction hose to the inlet pipe (1) of the DED pump assembly and connect other end of suction hose to water source. Highest point in the suction hose should be at the DED pump assembly.

2-8. INITIAL ADJUSTMENTS, DAILY CHECKS, AND SELF TESTS.

a. Inspect all DED pump assembly for completeness, damage, and for proper operation as applicable. Report any deficiencies to unit maintenance.

b. Perform the "Before" preventative maintenance checks and services listed in Table 2-1

2-9. OPERATING PROCEDURES.

a. Starting. After insuring that the DED pump assembly has been properly connected as indicated in para. 2-7, the DED pump assembly may be started by performing the following steps. (Refer to Figure 2-5.)

CAUTION

Starting the DED pump assembly before the pump has been initially primed can cause serious damage to the pump. Be sure that the pump has been initially primed as shown in para. 2-7.

(1) Perform all "Before" Operator PMCS listed in Table 2-1.

(2) Disengage the latch (1) on the access cover (2) of the enclosure assembly (3) and open access cover.

(3) Set fuel cock (4) to open position by turning handle to the downward position.

(4) Rotate throttle control handle (5) 1/4 turn counterclockwise, pull handle all the way out, and twist handle 1/4 clockwise to lock throttle in fully open position.

(5) Slowly pull out starting handle (6) until you feel resistance, and then return it to the initial position.

(6) Push the decompression lever down (7) and release. It will return automatically to the normal position when the recoil starter is pulled.

CAUTION

Do not allow the handle grip to snap back. Return it gently to prevent damage to the starter.

(7) Hold recoil starting handle (6) firmly and pull out the handle briskly. Engine will start and go to maximum operating speed

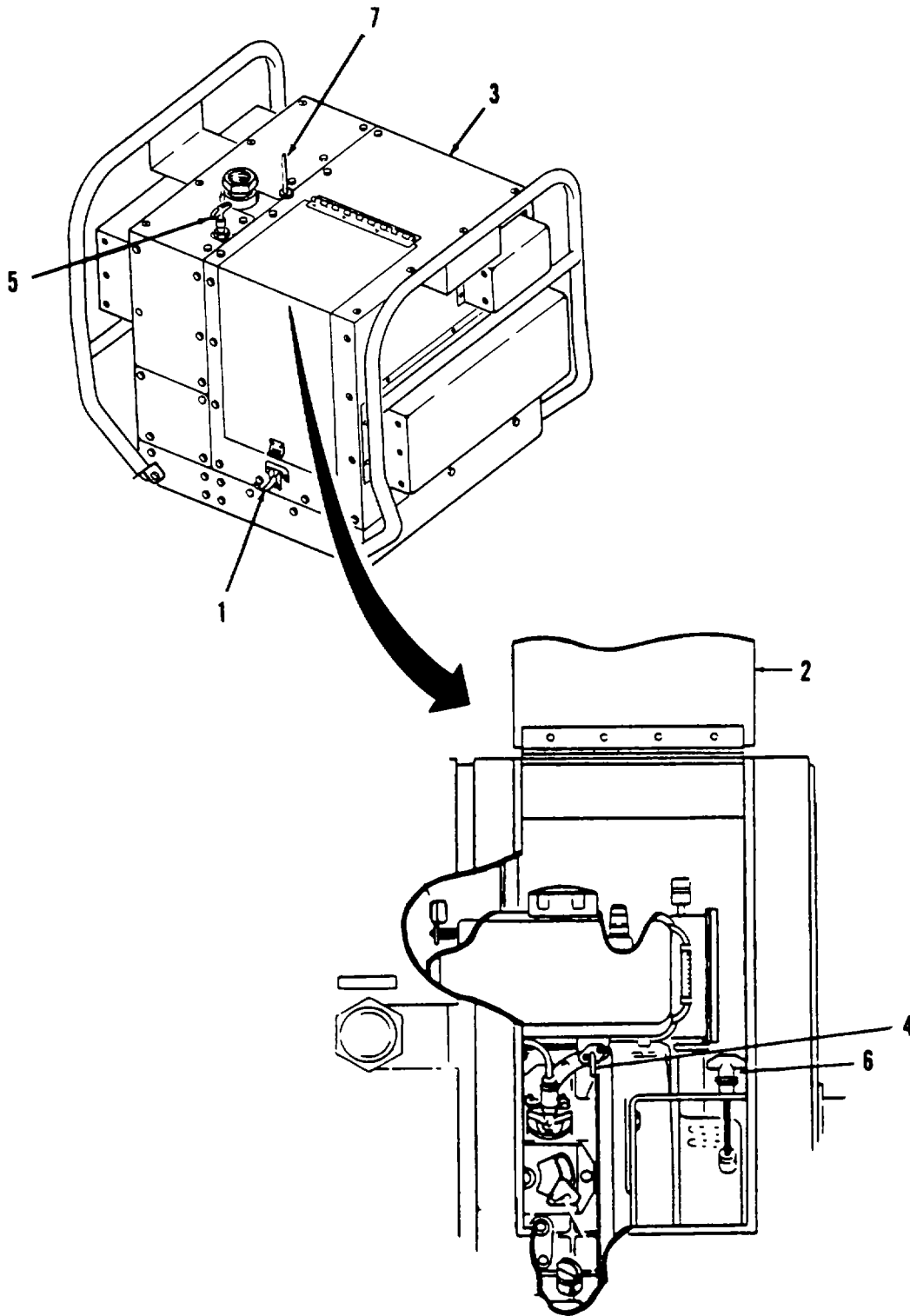

Figure 2-5. Starting and Operating the DED Pump Assembly.

NOTE

If engine does not start on first pull, repeat steps (5), (6), and (7).

- (8) After 1 to 3 minutes, the centrifugal pump will start pumping water.
- (9) Close access panel (2) and engage latch (1).

b. Adjusting Speed. After engine has been started, the engine speed must be adjusted to set the DED pump assembly to pump the required rate of water. To adjust the engine speed, perform the following steps. (Refer to Figure 2-5.)

- (1) Rotate throttle control handle (5) 1/4 turn counterclockwise and either pull out the throttle control to increase speed or push in throttle control handle to decrease speed until desired pumping rate is achieved.
- (2) Rotate throttle control handle (5) 1/4 turn clockwise to lock handle when the desired speed and pumping rate are achieved.

c. Stopping. When the pumping operation is complete, the DED pump assembly must be shutdown by stopping the engine. To shutdown the DED pump assembly, perform the following steps. (Refer to Figure 2-5.)

CAUTION

- **Do not stop engine suddenly since it may cause the temperature to get too high and cause possible damage to the engine. When stopping the engine, reduce the load slowly and allow the engine to run at idle speed for 3 minutes before stopping engine.**
- **Do not stop engine with the decompression lever as engine damage may result. If the engine cannot be stopped by the throttle control, then move the fuel cock handle to the horizontal to close the cock and cut off fuel flow to the engine.**

- (1) Rotate throttle control handle (5) 1/4 turn counterclockwise and slowly move throttle down until engine is running at idle speed. Lock throttle control into this idle position by rotating throttle control handle 1/4 turn clockwise.
- (2) Allow engine to run at idle speed for 3 minutes.
- (3) Close any discharge water valve in the water system and then close any suction valves that are installed in the hoses. This will retain liquid in pump unit and reduce or eliminate the need to prime the pump for the next pumping application.
- (4) Rotate throttle control handle (5) 1/4 turn counterclockwise and push throttle control handle all the way down to stop the engine.

2-10. PREPARATION FOR MOVEMENT. When the DED pump assembly is to be moved, the services of unit maintenance shall be employed for the necessary preparations. For general preparation of the DED pump assembly for movement, perform the following steps (Refer to Figure 2-3).

- a. Disconnect suction hose from DED pump assembly inlet pipe (1).
- b. Disconnect discharge hose from DED pump assembly outlet pipe (2).
- c. Open pump drain cock on the bottom pan frame and allow all water to drain from pump unit.

2-11. DECALS AND INSTRUCTION PLATES. To assist the operator in the use of the DED pump assembly, various decals and information plates have been placed on the unit. The location of each of these decals or instruction plates and the wording of each one is shown in Figure 2-6.

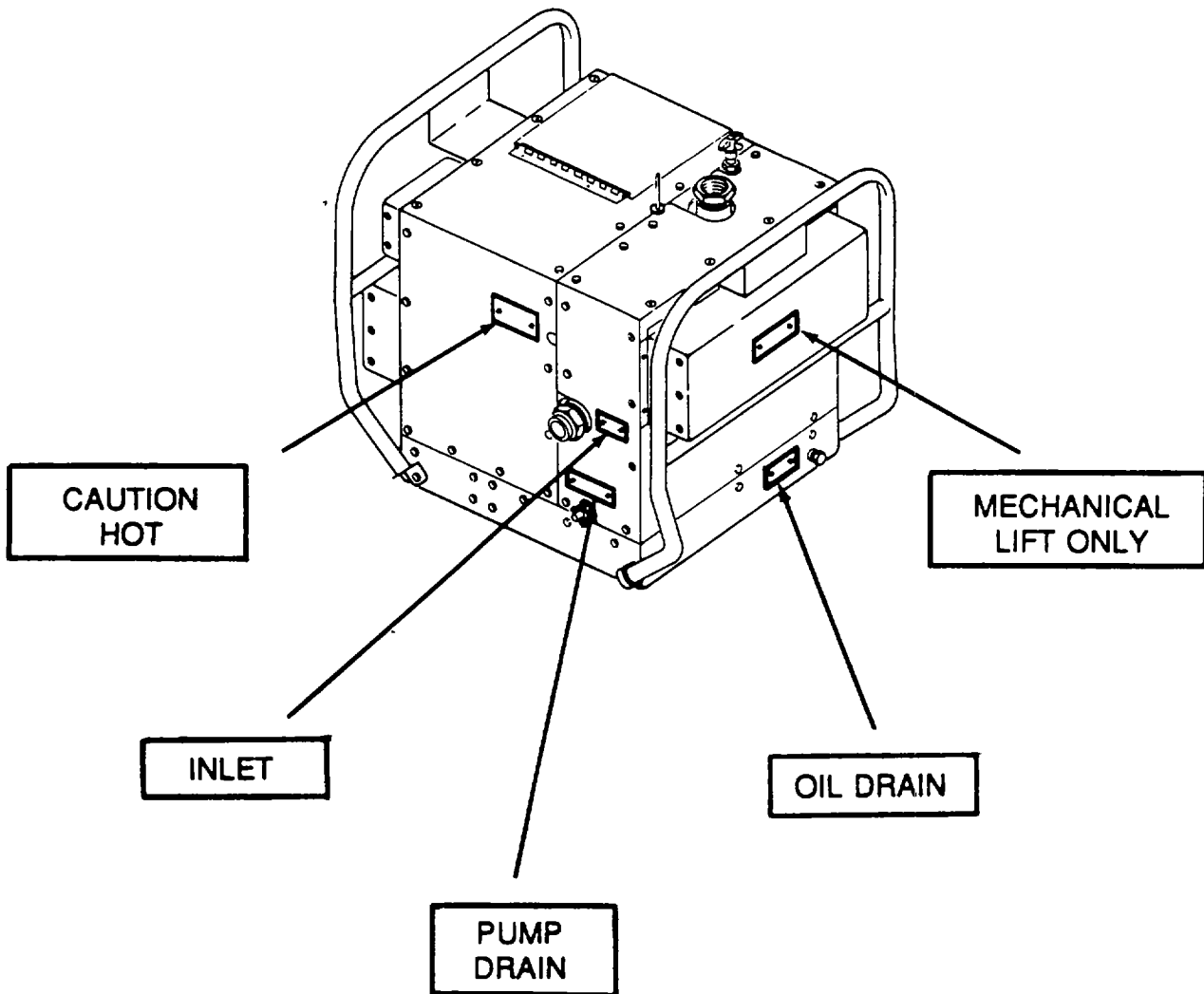

Figure 2-6. Decals and Instruction Plates. (Sheet 1 of 2).

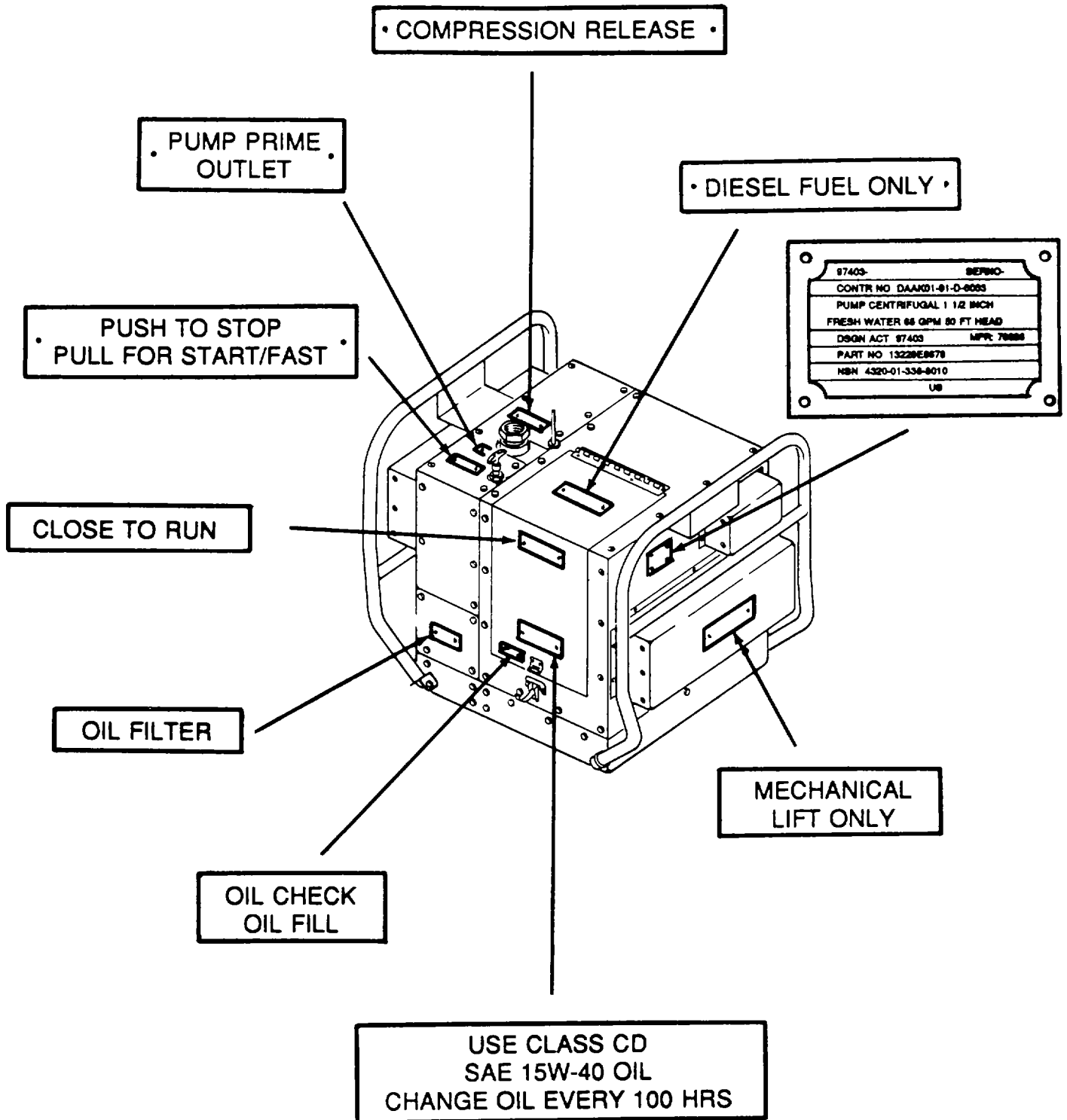

Figure 2-6. Decals and Instruction Plate. (Sheet 2 of 2).

SECTION IV. OPERATION UNDER UNUSUAL CONDITIONS

2-12. OPERATION UNDER UNUSUAL WEATHER. The DED pump assembly is designed to operate normally within a wide range of climatic conditions. However, some extreme conditions require special operating and servicing procedures to prevent undue loading and excessive wear on the equipment. These unusual conditions and the special steps to be performed are listed in the following paragraphs.

a. Operation in Extreme Cold. (Refer to Figure 2-7.)

CAUTION

Freezing water can badly damage the DED pump assembly components. When pumping operations are completed at temperatures near 32°F (0°C), disconnect each end of all hose assemblies to prevent freezing water from damaging equipment. This equipment is not designed for operation below 32°F (0°C).

(1) Be sure to use proper engine oil for cold weather. Refer to Lubrication Order LO10-4320-316-12 for the correct type of oil to use in the temperatures you will be experiencing.

(2) Keep fuel tank full to prevent condensation. Condensation can freeze and clog the lines, filters, and injectors. Water in the fuel can also make the engine hard to start and may make the engine run very roughly.

WARNING

Use of gasoline, paint thinner, or any other volatile liquid either as a fuel or as a starting aid can result in serious injury to operating personnel. Addition of highly volatile liquids put directly into engine could cause an explosion or fire.

CAUTION

Do not use more oil than specified as a starting agent or equipment damage could result. Too much oil could result in engine reversal. Should this occur, engine exhaust will be emitted from the air intake. Stop engine at once. The oil pump in the engine does not work in reverse and severe engine damage could result.

CAUTION

If plug is not in place contaminants may enter engine and cause accelerated wear of internal parts. Keep rubber plug in rocker arm cover except when adding oil for cold weather starting.

(3) Cold weather starting can be improved by the addition of engine oil in rocker arm cover. Remove rubber plug (1) of rocker arm cover and add five or six drops of engine oil before starting.

(4) Replace rubber plug (1) immediately after oil is added.

(5) Start the engine immediately as described in paragraph 2-9.

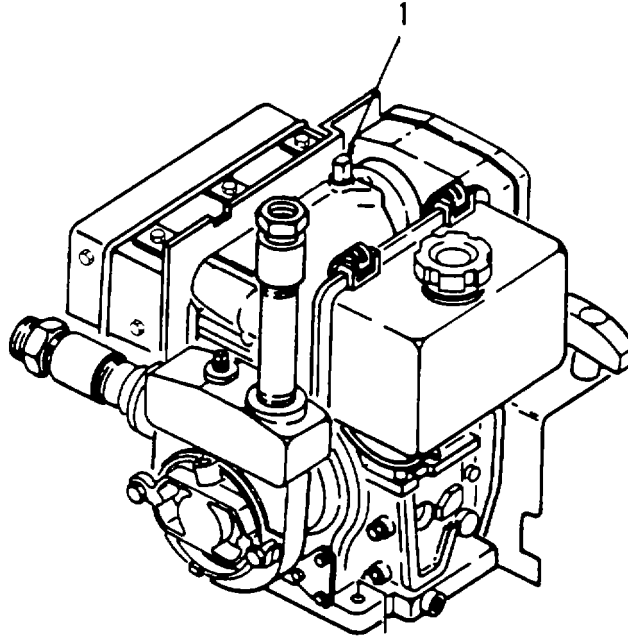

Figure 2-7. Cold Weather Starting Aid.

b. Operation in Extreme Heat.

- (1) Protect pump assembly from direct heat of the sun.
- (2) Make sure oil is maintained on the top oil level mark Refer to Lubrication Order L010-4320-316-12.
- (3) If overheating occurs in extreme conditions, shut down engine immediately. Be sure unit is operated in a well ventilated area capable of allowing exhaust air to dissipate and to allow cool fresh air to enter engine intake. If possible protect pump assembly from direct heat or the sun.

c. Operation in Sandy or Dusty Areas. Dusty and sandy conditions can seriously affect the operation of the DED pump assembly. When operating the DED pump assembly in these dusty and sandy conditions, perform the following steps.

- (1) Accumulation of dust or sand in the filters of the diesel engine will cause the pump to overheat and damage the equipment. Have engine air filter replaced by unit maintenance and clean all other areas of dust and sand accumulation frequently. In extreme conditions, daily replacement of filter may be necessary.
- (2) Water which has been contaminated by dust and sand can severely affect the usability of the water being pumped by the DED pump assembly. Special care must be taken that the water being pumped does not have dust or sand in it when using the DED pump assembly in dusty and sandy conditions. Be sure that all hose and piping connections are tight. Be sure that the insides of all DED pump assembly components are clean before piping connections are made during DED pump assembly set up and assembly.

2-12. OPERATION UNDER UNUSUAL WEATHER. - Continued.**c. Operation in Sandy or Dusty Areas. - Continued.**

(3) Check engine oil more often to make sure oil level is maintained at the top mark. Refer to Lubrication Order LO10-4310-316-12.

(4) During the handling of fuel, while performing any PMCS procedure, or while refueling, be sure that sand or dust is not allowed to enter fuel or lubrication system.

(5) If DED pump assembly is not in use and suction and/or discharge hoses are not installed, be sure that inlet and outlet pipe openings are covered.

d. Operation in Salt Water Areas. The nature of salt presents serious corrosion problems. Frequent cleaning is necessary during which all exposed surfaces should be thoroughly sprayed, rinsed, or sponged with fresh water to remove salt. Keep inlet and outlet pipes on the DED pump assembly free from dried salt to insure that water being pump for potable water use is not contaminated.

2-13. EMERGENCY PROCEDURES. Loss of suction requires a shutdown of the diesel-driven centrifugal pump as soon as possible.

CAUTION

Do not stop engine with the decompression lever as engine damage may result. If the engine cannot be stopped by the throttle control handle, then move the fuel cock to the closed position to stop the flow of fuel to the engine.

Rotate throttle control handle 1/4 turn counterclockwise and push handle all the way down to stop engine.

2-14. NUCLEAR, BIOLOGICAL, AND CHEMICAL (NBC) DECONTAMINATION PROCEDURES. In the event that the pumping assembly has been subjected to NBC contamination, follow the NBC procedures in FM 3-3, FM 3-4, and FM 3-5.

**CHAPTER 3
OPERATOR MAINTENANCE INSTRUCTIONS**

SECTION I. LUBRICATION INSTRUCTIONS

3-1. GENERAL. Refer to Lubrication Order LO10-4320-316-12 for the for proper lubrication procedures.

SECTION II. OPERATOR TROUBLESHOOTING PROCEDURES

3-2. INTRODUCTION. This section contains troubleshooting information for locating and correcting most of the operating troubles which may develop in the DED pump assembly. Each malfunction for an individual component, unit, or system is followed by a list of tests or inspections which will help you to determine corrective actions to take You should perform the tests/inspections and corrective actions in the order listed.

This manual cannot list all malfunctions that may occur, nor all tests or inspections and corrective actions. If a malfunction is not listed, or is not corrected by listed corrective actions, notify your supervisor.

Table 3-1 lists the common malfunctions which you may find during the operation or maintenance of the DED pump assembly or its components. You should perform the tests/inspections and corrective actions in the order listed.

3-3. MALFUNCTION INDEX.

MALFUNCTION	PAGE NO.
STARTING HANDLE FAILS TO PULL	3-2
STARTING HANDLE PULLS, BUT ENGINE FAILS TO START	3-2
ERRATIC RUNNING OR FREQUENT STALLING.....	3-2
LACK OF POWER	3-2
ENGINE STOPS RUNNING	3-3
PUMP FAILS TO PUMP WATER.....	3-3
LOW DISCHARGE FLOW RATE	3-3

3-4. OPERATOR TROUBLESHOOTING TABLE. Refer to Table 3-1 for the operator troubleshooting procedures authorized for the DED pump assembly.

Table 3-1. Operator Troubleshooting.

MALFUNCTION	TEST OR INSPECTION	CORRECTIVE ACTION
1. STARTING HANDLE FAILS TO PULL.	Check decompression lever.	Push decompression lever down to release engine compression. (Refer to para 2-9.)
		If starting handle still fails to pull, notify Unit Maintenance.
2. STARTING HANDLE PULLS, BUT ENGINE FAILS TO START.	Step 1. Check fuel cock.	Open fuel cock, if closed (refer to para 2-9).
		If fuel cock is open proceed to step 2.
	Step 2. Check position of throttle control handle.	Move to START position (refer to para 2-9).
		If throttle control handle is properly positioned, proceed to step 3.
	Step 3. Check the starting procedure under prevailing conditions. (Refer to Chapter 2, Section III or IV.)	If the starting procedures have been performed correctly ND engine still fails to start, notify Unit Maintenance.
3. ERRATIC RUNNING OR FREQUENT STALLING.	Check for partially closed fuel cock.	Fully open the fuel cock, if closed (refer to para 2-9).
		If unit still runs improperly, notify Unit Maintenance.
4. LACK OF POWER.	Step 1. Check position of throttle control handle.	Move to START position to increase engine speed (refer to para 2-9).
		If engine still lacks power, proceed to step 2.

Table 3-1. Operator Troubleshooting.

MALFUNCTION	TEST OR INSPECTION	CORRECTIVE ACTION
	<p>Step 2. Check for clogged suction hose in system.</p>	<p>Check all suction hoses attached to inlet pump piping for clogged or collapsed hoses. Clean out clogged hoses and reposition or replace collapsed suction hoses. (Refer to system technical manual).</p> <p>If suction hoses are not clogged or collapsed, contact Unit Maintenance.</p>
	<p>5. ENGINE STOPS RUNNING.</p>	<p>Check for low fuel supply.</p> <p>Fill fuel tank, if necessary.</p> <p>If fuel tank has fuel, notify Unit Maintenance.</p>
	<p>6. PUMP FAILS TO PUMP WATER.</p>	<p>Step 1. Check pump priming procedure. (Refer to para. 2-9).</p> <p>If pump is properly primed, proceed to Step 2.</p> <p>Step 2. Check for clogged suction hose.</p> <p>If clogged, clean suction hose. Refer to system technical manual.</p> <p>If suction hose is not clogged, proceed to Step 3.</p> <p>Step 3. Check for leaks in the pump suction line.</p> <p>Repair leaks in pump suction line. Refer to system technical manual.</p> <p>If suction line is not clogged, notify Unit Maintenance.</p>
	<p>7. LOW DISCHARGE FLOW RATE.</p>	<p>Step 1. Check for low engine speed.</p> <p>Move throttle control handle to START position to increase engine speed (refer to para 2-9).</p> <p>If engine speed is correct, proceed to step 2.</p>

Table 3-1. Operator Troubleshooting. - Continued.

MALFUNCTION	TEST OR INSPECTION	CORRECTIVE ACTION
	Step 2. Check for lack of engine power.	Refer to MALFUNCTION 4.
		If engine does not lack power, proceed to step 3.
	Step 3. Check for clogged suction hose.	If clogged, clean suction hose. Refer to system technical manual.
		If suction hose is not clogged, proceed to Step 4.
	Step 4. Check for leaks in the pump suction line.	Repair leaks in suction port connections. Refer to system technical manual.
		If suction line is not leaking, notify Unit Maintenance.

SECTION III. OPERATOR MAINTENANCE PROCEDURES

3-5. GENERAL. This section contains the maintenance procedures which the Maintenance Allocation Chart authorizes the operator to perform. If the DED pump assembly still does not operate properly after performing these maintenance procedures, contact unit maintenance for assistance.

3-6. SERVICING FUEL INLET FILTER. To service the fuel inlet filter, perform the following steps. (Refer to Figure 3-1.)

a. Removal

- (1) Remove fuel tank cap (1) from fuel tank (2)
- (2) Remove fuel inlet filter (3) from fuel tank (2).

b. Servicing

- (1) Remove any debris that has collected inside the fuel inlet filter (3).
- (2) If fuel inlet filter cannot be cleaned, contact unit maintenance for a replacement filter.

c. Installation

- (1) Install fuel inlet filter (3) into fuel tank (2)
- (2) Install fuel tank cap (1) onto fuel tank (2).

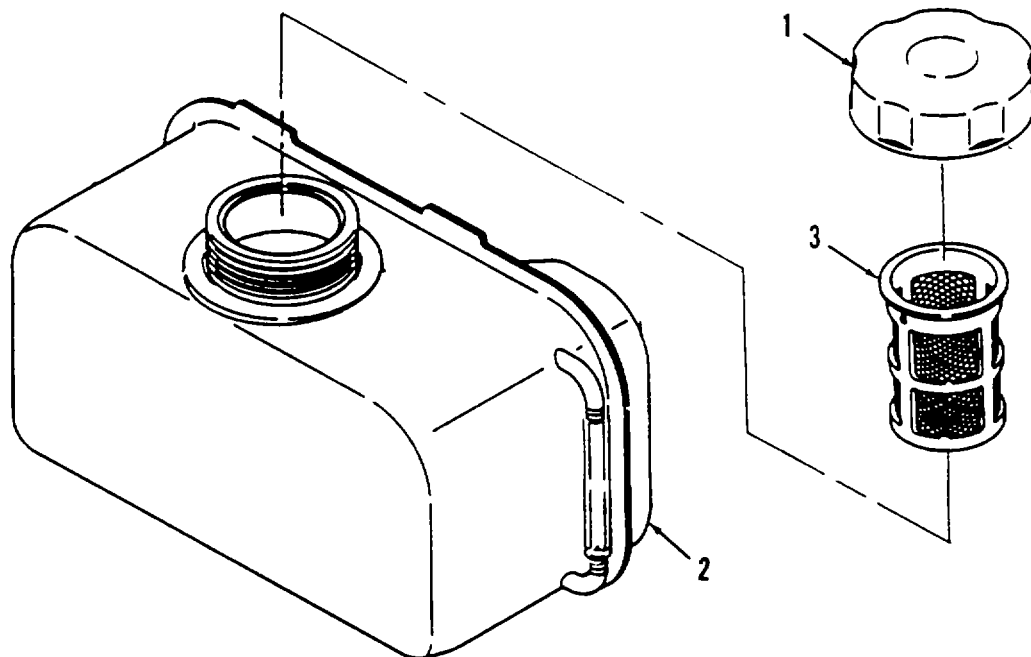

Figure 3-1. Servicing Fuel Inlet Filter.

3-7. SERVICING ENGINE AIR CLEANER FILTER ELEMENT. To service the engine air cleaner filter element, perform the following steps. (Refer to Figure 3-2.)

a. Removal

- (1) Remove wing nut (1) and washer (2).
- (2) Remove air cleaner cover (3) from air cleaner assembly (4).
- (3) Remove air cleaner element (5) from air cleaner assembly (4).

b. Servicing.

- (1) Remove any dirt or debris from inside air cleaner housing.
- (2) If filter element is dirty, contact unit maintenance for a replacement element.

c. Installation.

- (1) Install air cleaner element (5) into air cleaner assembly (4).
- (2) Install air cleaner cover (3) onto air cleaner assembly (4) and install washer (2) and wing nut (1).

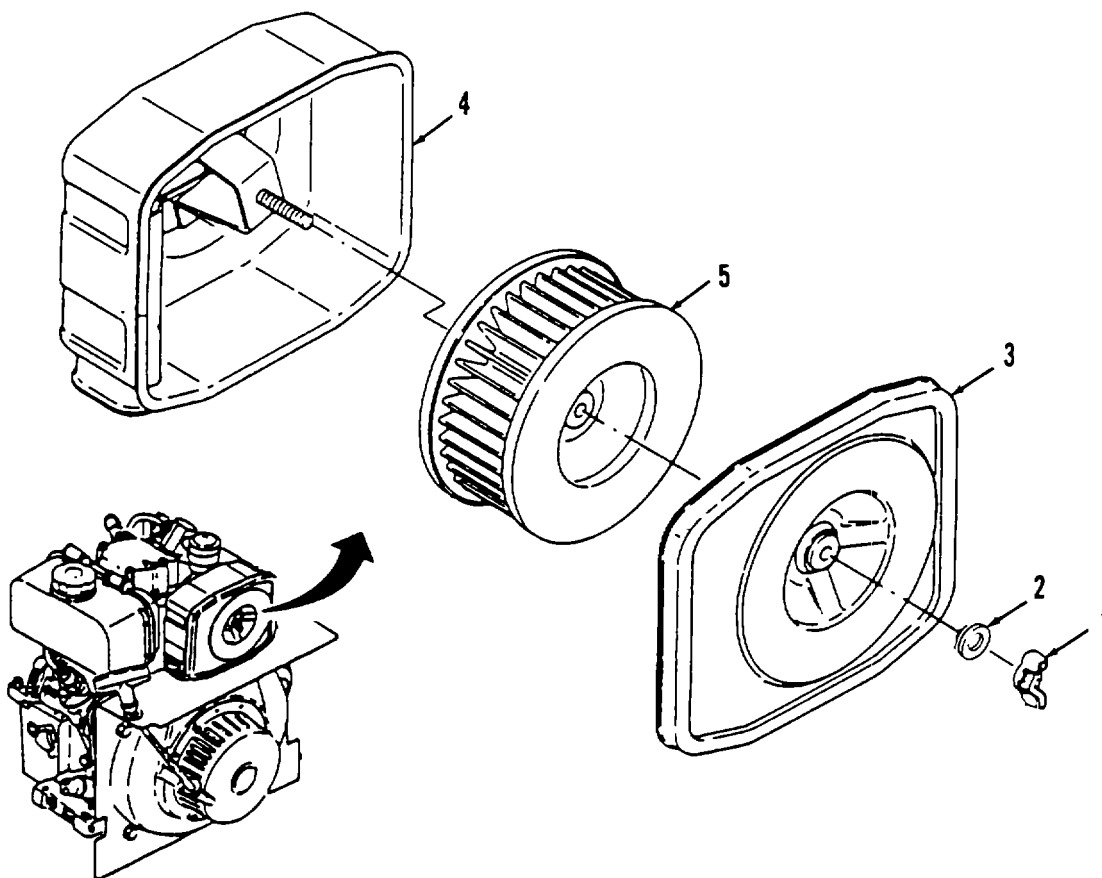

Figure 3-2. Servicing Air Cleaner Filter Element.

CHAPTER 4

UNIT MAINTENANCE INSTRUCTIONS

SECTION I. REPAIR PARTS, SPECIAL TOOLS, TEST, MEASUREMENT, AND DIAGNOSTIC EQUIPMENT (TMDE), AND SUPPORT EQUIPMENT

4-1. COMMON TOOLS AND EQUIPMENT. For authorized common tools and equipment, refer to the Modified Table of Organization and Equipment (MTOE) applicable to your unit.

4-2. SPECIAL TOOLS, TMDE, AND SUPPORT EQUIPMENT. No special tools are required for maintenance of the equipment. Test, Measurement, and Diagnostic Equipment (TMDE) and Support Equipment include standard equipment found in any maintenance shop.

4-3. REPAIR PARTS. Repair parts are listed and illustrated in the Repair Parts and Special Tools List (RPSTL), TM 10-4320-316-24P, covering unit, direct support, and general support maintenance for this equipment.

SECTION II. SERVICE UPON RECEIPT

4-4. SITE AND SHELTER REQUIREMENTS. Before beginning installation of the DED pump, be sure that you have selected the proper site and shelter for the unit as described in the following paragraphs.

WARNING

CARBON MONOXIDE (EXHAUST GAS) CAN KILL YOU

Carbon monoxide is without color or smell, but can kill you. Breathing air with carbon monoxide produces symptoms of headache, dizziness, loss of muscular control, a sleepy feeling, and coma. Heavy exposure can cause brain damage or death. Carbon monoxide gas occurs in the exhaust fumes of internal combustion engines, and can become dangerously concentrated under conditions of no air movement. To ensure your safety and that of other maintenance personnel, always observe the following precautions:

- DO NOT operate engine in a closed place unless the place has a lot of moving air. Engine should be kept at least five feet away from buildings and other equipment during operation.
- DO NOT idle engine for long periods without proper ventilation.
- BE ALERT at all times for exhaust odors and exposure symptoms. If either is present, IMMEDIATELY VENTILATE personnel compartments; remove affected crew to fresh air; keep warm; if necessary, give artificial respiration. FOR ARTIFICIAL RESPIRATION REFER TO FM 21-11.
- BE AWARE; the field protective mask for chemical-biological-radiological (CBR) protection will not protect you against carbon monoxide poisoning.

THE BEST DEFENSE AGAINST CARBON MONOXIDE POISONING IS GOOD VENTILATION.

4-4. SITE AND SHELTER REQUIREMENTS. Continued.

a. Siting. Select an installation site for the DED pump assembly that is relatively level. Be very sure that the site you have selected will provide adequate air circulation around the unit to prevent dangerous accumulation of poisonous exhaust gases from the engine.

b. Shelter Requirements. Operation of the DED pump within a shelter is not recommended since the collection of exhaust gases present extremely dangerous hazards to operating personnel.

4-5. SERVICE UPON RECEIPT. The following paragraphs contain the procedures for unloading, unpacking, and general checking of the unpacked DED pump.

a. Unloading. The DED pump is packaged in a container designed for shipment and handling with the unit in an upright position. The base of the container is constructed as a shipping pallet with provisions for the insertion of the tongs of a fork-lift. The unit may be lifted by fork-lift, crane, or sling. To unload the DED pump, perform the following steps.

- (1) Remove all blocking and tie downs that may have been used to secure the container to the carrier.

WARNING

Do not allow the unit to swing while suspended from a lifting device. Failure to observe this warning may result in injury to personnel and damage to the equipment.

CAUTION

Use care in handling to avoid damage to the DED pump. If an overhead lifting device must be used, use an appropriate sling so that the weight of the unit is supported by the base of the shipping container.

- (2) Use a forklift truck or other suitable material handling equipment to remove the unit from the carrier.

b. Unpacking.**CAUTION**

To protect the DED pump and prevent damage, the DED pump should be left packaged until it is moved to the location where it is to be installed.

NOTE

The shipping container is of such a design that it may be retained for re-use for mobility purposes if frequent relocation of the DED pump is anticipated.

- (1) Cut the metal bands that hold the top of the shipping container to the base.
- (2) Remove the cushioning around the top of the unit's sound enclosure and retain, if re-use is anticipated.

- (3) Remove the preservation barrier by tearing around the bottom of the unit.
- (4) Remove the technical publications envelope and accessory sack that are taped to the unit and put them in a safe place.

WARNING

To avoid serious injury to personnel, always use a suitable lifting device to move or lift pumping assembly.

- (5) Remove the DED pump from the shipping container by lifting it up and out of the container. Place the unit into a position where it can be checked for completeness and possible shipping damage.
- (6) Remove the shipping container from the site and retain it if re-use is anticipated. Be sure to remove all remaining barrier material from the underside of the unit.

c. Checking Unpacked Equipment. To check the unpacked DED pump, perform the following steps.

- (1) Inspect the equipment for damage incurred during shipment. If the equipment has been damaged, report damage on DD Form 6, Packaging Improvement Report.
- (2) Check the equipment against the packing slip to see if the shipment is complete. Report all discrepancies in accordance with the instructions as defined within DA PAM 738-750. See that all components of end item and basic issue items are with the equipment.
- (3) Check to see whether the equipment has been modified.

4-6. INSTALLATION INSTRUCTIONS. Before the DED pump can be properly operated, the unit must be installed into the system which requires the use of the pump. To install the DED pump into the system, perform the following instructions.

a. Tools, Test Equipment, and Materials Needed for Installation. The standard tool kit commonly available to unit level maintenance contains all the tools required to install the DED pump.

b. Assembly of Equipment.

CAUTION

Improper installation of pipe fittings can cause the DED pump to leak badly and could cause damage to the pump or other system components. Be sure that all threaded male pipe fittings have four clockwise wraps of teflon tape before fittings are installed.

- (1) Install feet to bottom pan frame (refer to para. 4-25.)
- (2) Install the suction hose to be used in the system onto the suction port of the DED pump. Highest point in the suction hose should be at the pump.
- (3) Install the discharge hose to be used in the system onto the outlet port of the DED pump.

4-6. INSTALLATION INSTRUCTIONS. Continued.**b. Assembly of Equipment.** - Continued.

- (4) Make sure all connections are tight.
- (5) After the DED pump has been assembled, the following steps must be performed before attempting to start the engine.
 - (a) Fill the fuel tank with diesel fuel (Refer to paragraph 2-7).
 - (b) Make sure the engine is perfectly level. Remove the dipstick cap and fill with oil according to the ambient temperature. (Refer to L010-4320-316-12.)
 - (c) Check the oil level by inserting the dipstick into the oil pan without screwing in the dipstick.
 - (d) Check that there is no obstruction in front of the air intake opening that might impede the flow of cooling air.
 - (e) Check that there is no obstruction that might hinder pull-rope action.

SECTION III. LUBRICATION

4-7. GENERAL. Refer to Lubrication Order LO10-4320-316-12 for the lubrication instructions required for this unit.

SECTION IV. UNIT PREVENTIVE MAINTENANCE CHECKS AND SERVICES (PMCS)

4-8. INTRODUCTION. Systematic, periodic, Preventive Maintenance Checks and Services (PMCS) are essential to ensure that the DED pump is ready for operation at all times. The purpose of a preventive maintenance program is to discover and correct defects and deficiencies before they can cause serious damage or complete failure of the equipment. Any effective preventive maintenance program must begin with the indoctrination of operators to report all unusual conditions notes during daily checks or actual operation to unit maintenance. All defects and deficiencies discovered during maintenance inspections must be recorded, together with corrective action taken, on DA Form 2404 (Equipment Inspection and Maintenance Worksheet).

A schedule for unit preventive maintenance inspection and service should be established immediately after installation of the DED pump. A quarterly interval, equal to three calendar months or 250 hours of operation (whichever occurs first) is recommended for usual operating conditions. When operating under unusual conditions, such as a very dusty or sandy environment, it may be necessary to reduce the interval to monthly or even less if conditions are extreme.

Table 4-1 lists the unit preventive maintenance checks and services that should be performed at quarterly (or otherwise established) intervals. The PMCS items in the table have been arranged and numbered in a logical sequence to provide for greater personnel efficiency and least amount of required maintenance downtime.

4-9. PMCS TABLE. Refer to Table 4-1. for the unit Preventive Maintenance Checks and Services required for the DED pump. A description of the columns in the table is included in the following paragraphs.

a. Item Number Column. This column is a list of every check and service task in the PMCS. They are numbered in logical order of performance regardless of the interval. This column is to be used as a source of item numbers for the TM Number Column on DA Form 2404, Equipment Inspection and Maintenance Worksheet, in recording results of PMCS.

b. Interval Column. This column is subdivided into four categories. W-Weekly, M-Monthly, Q-Quarterly, and S-Semi-annually. A dot in the appropriate column signifies the interval at which a specific item needs to be checked or serviced.

c. Item To Be Inspected Column. This column provides the name of the item to be checked or serviced.

d. Procedures Column. This column describes the procedures to check or service an item. It includes all the information required to perform the checks or services. It indicates tolerances where applicable, adjustment limits, and reading levels where required.

Table 4-1. Unit Preventive Maintenance Checks and Services (PMCS)

Item No.	Interval	Location Item To Check/ Service	Procedure	Not Fully Mission Capable If
1	Monthly	Suction Flange Assembly	<p>a. Tilt open outlet enclosure (refer to para. 4-23)</p> <p>b. Remove hose connection adapter (1), coupling (2), and pipe nipple (3) from suction pipe flange assembly (4) on unit (5).</p> <p>c. Look into port of suction flange assembly (4) to check that internal gasket is not missing or damaged or that either of the two weights on the gasket are not missing or damaged.</p> <p>d. If the gasket has been damaged, notify direct support maintenance.</p> <p>e. Install pipe nipple (3), coupling (2) and hose connection adapter (1) into suction flange assembly (4).</p> <p>f. Close outlet enclosure (refer to para 4-23).</p>	Gasket or gasket weights missing or damaged

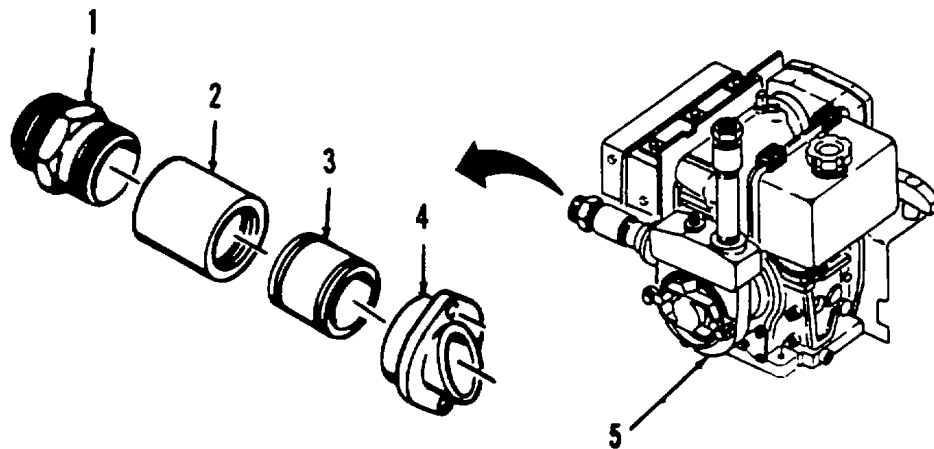

Table 4-1. Unit Preventive Maintenance Checks and Services (PMCS) - Continued.

Item No.	Interval	Location Item To Check/ Service	Procedure	Not Fully Mission Capable If
2	Quarterly	Pump Cover Plate	a. Tilt open outlet enclosure (see para. 4-23). b. Check surface of pump cover plate for cracks and leaks. Check that cover plate mounting bolts are not missing or are not tight c. If bolts are missing or cover plate is damaged, notify direct support maintenance. d. Tighten any loose cover plate mounting bolts. e. Close outlet enclosure (see para. 4-23).	Pump cover plate cracked Cover plate mounting bolts overtightened or missing.
3	Quarterly	Air Intake Pipe	a. Inspect engine air intake pipe for loose or missing mounting hardware. b. Check for damaged air intake pipe gasket. Notify direct support maintenance if air intake pipe or gasket is damaged.	Loose or missing mounting hardware Damaged air intake pipe gasket.
4	Quarterly	Cooling Case Fan	a. Remove inlet enclosure (see para. 4-22). b. Inspect engine cooling fan case (1) for loose or missing mounting hardware c. Check cooling fan case for cracked or damaged surfaces. d. If cooling fan case is damaged, notify direct support maintenance. e. Install inlet enclosure (see para. 4-22).	Cooling fan case cracked or damaged. Loose or missing mounting hardware

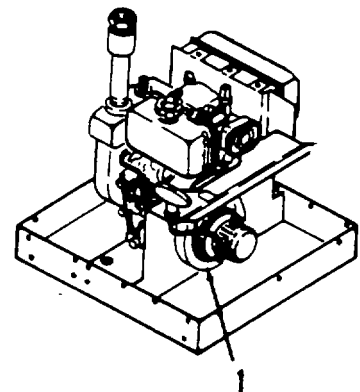

Table 4-1. Unit Preventive Maintenance Checks and Services (PMCS)

Item No.	Interval	Location Item To Check/ Service	Procedure	Not Fully Mission Capable If
5	Quarterly	Lube Oil Strainer	a. Remove inlet enclosure (see para. 4-22). b. Remove bolt (1), lube oil strainer (3), and O-ring (2). c. Clean any dirt and debris that may have collected in the lube oil strainer (3) d. Check lube oil strainer (3) for damaged screen or cracked O-ring (2) If repairs are required, refer to para. 4-35. e. Install O-ring (2), lube oil strainer (3), and bolt (1). f. Install inlet enclosure (see para. 4-22).n	Lube oil strainer dirty. Lube oil stainer screen O- ring damaged or cracked.
6	Annually	Baffles	a. Check baffles for missing, loose or damaged rubber seals. b. If baffles are damaged, refer to para 4-21 to repair baffles.	Baffles rubber seals missing or damaged
7	Annually	Fuel Filter, Outlet	Replace outlet fuel filter (see para. 4-29).	
8	Annually	Exhaust Silencer	a. Check exhaust silencer for holes. b. If exhaust silencer is defective, notify direct support maintenance	

SECTION V. UNIT TROUBLESHOOTING PROCEDURES.

4-10. GENERAL. This section contains troubleshooting information for locating and correcting most of the operating troubles which may develop in the DED pump. Each malfunction for an individual component, unit, or system is followed by a list of tests or inspections which will help you to determine corrective actions to take. You should perform the tests/inspections and corrective actions in the order listed.

In general, engine exhaust is an excellent way to tell what kind of condition your centrifugal pump is in. Exhaust color of black, or bluish-white, smoke is normal before the engine warms up fully. As the engine reaches normal operating temperature, the exhaust becomes clear or light blue, provided there are no problems. If the exhaust does not clear up, a problem is indicated.

When exhaust color is abnormal, turn off the engine immediately and notify your supervisor. Use Table 4-2 as a guideline to exhaust symptoms.

Table 4-2. Troubleshooting by Exhaust Color.

EXHAUST COLOR:	LIKELY INDICATES:
Clear or light bluish condition	Normal operating
Continuous black smoke	Overloading Seizure of moving part Incorrect combustion
Continuous bluish-white smoke	Lubricating oil is being consumed

This manual cannot list all malfunctions that may occur, nor all tests or inspections and corrective actions. If a malfunction is not listed, or is not corrected by listed corrective actions, notify your supervisor.

Table 4-3 lists the common malfunctions which you may find during the operation or maintenance of the DED pump. You should perform the tests/inspections and corrective actions in the order listed.

WARNING
CARBON MONOXIDE (EXHAUST GAS) CAN KILL YOU

Carbon monoxide is without color or smell, but can kill you. Breathing air with carbon monoxide produces symptoms of headache, dizziness, loss of muscular control, a sleepy feeling, and coma. Heavy exposure can cause brain damage or death. Carbon monoxide gas occurs in the exhaust fumes of internal combustion engines, and can become dangerously concentrated under conditions of no air movement. To ensure your safety and that of other maintenance personnel, always observe the following precautions:

- DO NOT operate engine in a closed place unless the place has a lot of moving air. Engine should be kept at least five feet away from buildings and other equipment during operation.
- DO NOT idle engine for long periods without proper ventilation.
- BE ALERT at all times for exhaust odors and exposure symptoms. If either is present, IMMEDIATELY VENTILATE personnel compartments; remove affected crew to fresh air; keep warm; if necessary, give artificial respiration. FOR ARTIFICIAL RESPIRATION REFER TO FM 21-11.
- BE AWARE; the field protective mask for chemical-biological-radiological (CBR)

THE BEST DEFENSE AGAINST CARBON MONOXIDE POISONING IS GOOD VENTILATION.

To assist the unit maintenance of the DED pump unit, the following index of the troubleshooting symptoms contained in this chapter are provided for quick reference.

MALFUNCTION	PAGE NO.
STARTING HANDLE FAILS TO PULL.....	4-11
HANDLE PULLS, BUT ENGINE FAILS TO START	4-11
ERRATIC RUNNING OR FREQUENT STALLING	4-12
LACK OF POWER.....	4-13
ENGINE STOPS RUNNING	4-13
PUMP DOES NOT PUMP WATER.....	4-13
EXCESSIVE LUBRICATION OIL CONSUMPTION.....	4-13
RECOIL STARTER ROPE BINDS	4-14
ENGINE CRANKSHAFT DOES NOT TURN AS THE ROPE IS PULLED.....	4-14

NOTE

Before you use this table, be sure you have performed all applicable operating checks.

Table 4-3. Unit Troubleshooting.

MALFUNCTION	TEST OR INSPECTION	CORRECTIVE ACTION
1. STARTING HANDLE FAILS TO PULL.		
Step 1. Check recoil starter assembly for binding.		
Inspect recoil starter operation per para. 4-33.		
If recoil starter is not binding, proceed to step 2.		
Step 2 Check for inoperable pump assembly.		
Remove pump cover plate and check for binding, jamming, or rubbing of internal pump components (see para. 4-26).		
If pump assembly is operating properly, notify Direct Support Maintenance.		
2. HANDLE PULLS; BUT ENGINE FAILS TO START.		
Step 1. Check for air in fuel injection line.		
Open sound enclosure door.		
Disconnect fuel injection line from fuel injection valve. (See para. 4-30)		
Push decompression lever down and keep it down.		
Pull the recoil starter handle several times with decompression lever down until fuel begins to flow from fuel injection line.		
Reconnect fuel injection line to fuel injection valve and attempt to restart engine.		
If engine fails to start, proceed to step 2.		
Step 2. Check for clogged fuel injector line.		
Disconnect fuel injection line from fuel injector valve and fuel injector pump and check for clogged line. (See para. 4-30).		
If fuel injection line is clogged, clean it.		
If fuel injection line is not clogged, proceed to step 3.		

Table 4-3. Unit Troubleshooting. - Continued.

MALFUNCTION	TEST OR INSPECTION	CORRECTIVE ACTION
2. HANDLE PULLS, BUT ENGINE FAILS TO START. - Continued.		
Step 3. Check for clogged fuel line hoses.		
Disconnect and check all fuel line hoses for clogging. (See para. 4-30).		
If fuel lines are clogged, clean them.		
If fuel lines are not clogged, proceed to step 4.		
Step 4. Check for defective fuel injection pump.		
Disconnect fuel injection line from fuel injection pump. (See para. 4-30).		
Pull recoil starter handle a few times to check that fuel flows from fuel injection pump outlet.		
If fuel does not flow from fuel injection pump outlet, replace fuel injection pump. (See para. 4-34).		
If fuel flows from fuel injection pump, reconnect fuel injection line to fuel injection pump and notify Direct Support Maintenance.		
3. ERRATIC RUNNING OR FREQUENT STALLING.		
Step 1. Check for clogged air cleaner element.		
Remove air cleaner element and check for clogging (see para. 3-7). Replace clogged air cleaner element.		
If air cleaner element is not clogged, proceed to step 2.		
Step 2. Check for defective fuel cock or clogged fuel outlet filter.		
Remove fuel cock and check for proper operation (see para. 4-29). Replace defective fuel cock.		
Remove fuel outlet filter and check for clogging (see para. 4-29). Replace clogged fuel outlet filter.		
If fuel cock is not defective and fuel outlet filter is not clogged, proceed to step 3.		
Step 3. Check for defective fuel injection pump.		
Refer to Malfunction 2, Step 4.		

Table 4-3. Unit Troubleshooting. - Continued.

MALFUNCTION	TEST OR INSPECTION	CORRECTIVE ACTION
		<p>If fuel injection pump is not defective, proceed to step 4.</p> <p>Step 4. Check for clogged exhaust silencer.</p> <p>If very little air is flowing from engine exhaust, check exhaust silencer per para. 4-32. Replace defective exhaust silencer.</p> <p>If exhaust silencer is not defective, notify Direct Support Maintenance.</p>
4. LACK OF POWER.		<p>Refer to Malfunction 3, steps 1, 2, 3, and 4.</p>
5. ENGINE STOPS RUNNING.		<p>Refer to Malfunction 2, steps 1, 2, 3, and 4.</p>
6. PUMP DOES NOT PUMP WATER.		<p>Step 1. Check for broken or misadjusted peeler.</p> <p>Check peeler for adjustment per para. 4-26.</p> <p>If peeler is not broken or out of adjustment, proceed to step 2.</p> <p>Step 2. Check for improper impeller clearance.</p> <p>Check impeller clearance per para. 4-26.</p> <p>If impeller clearance is correct, proceed to step 3.</p> <p>Step 3. Check for damaged pump components or broken pump body.</p> <p>Replace any damaged pump components per para. 4-26.</p> <p>If pump body is broken, replace pump unit per para. 4-26.</p>
7. EXCESSIVE LUBRICATION OIL CONSUMPTION.		<p>Inspect engine crankcase for leaks.</p> <p>Tighten oil drain plug or oil filler cap.</p> <p>If oil drain plug and oil filler cap are tight, notify Direct Support Maintenance.</p>

Table 4-3. Unit Troubleshooting. - Continued.

MALFUNCTION	TEST OR INSPECTION	CORRECTIVE ACTION
8. RECOIL STARTER ROPE BINDS.	Step 1. Check for defective recoil starter.	Remove and inspect recoil starter. (See para. 4-33.) Replace recoil starter if defective. If recoil starter is not defective, proceed to Step 2.
	Step 2. Check for defective pump assembly.	Inspect pump assembly for proper operation. (Refer to para. 4-26.) If pump assembly is defective, repair or replace it. If pump assembly is not defective, notify Direct Support Maintenance.
9. ENGINE CRANKSHAFT DOES NOT TURN AS THE ROPE IS PULLED.		Replace recoil starter. (Refer to para. 4-33.)

SECTION VI. UNIT MAINTENANCE PROCEDURES

4-11. INTRODUCTION. Maintenance procedures at unit level of maintenance include as necessary: removal, cleaning and inspection, repair or replacement, and installation. Unless the procedure requires special resources or tools, more than one maintenance person or specific equipment conditions, these are not listed for each maintenance procedure. They are listed only for those procedures that require them.

4-12. IDENT PLATES REPLACEMENT.

This Task Covers:

- a. Removal
 - b. Installation
-

Initial Setup:**Tools Required**

- Tool Kit, General Mechanic's (Appendix B, Item 1)
- Bit, Drill, .125 in. dia. (Appendix B, Item 2)
- Drill, Hand Portable (Appendix B, Item 2)
- Riveter, Blind, Hand (Appendix B, Item 5)

Material's Required

None

Equipment Condition

DED pump assembly shut down and cool.

- a. **Removal** (Refer to Figure 4-1).

NOTE

This procedure describes the replacement of one ident plate. Repeat the procedure as necessary for all other name plates.

- (1) Drill out rivets (1) that holds ident plate (2) onto unit.
- (2) Remove ident plate (2) from unit.

- b. **Installation.**

- (1) Place ident plate (2) into position on unit and insert two rivets (1).
- (2) Install two rivets (1) using hand riveter.

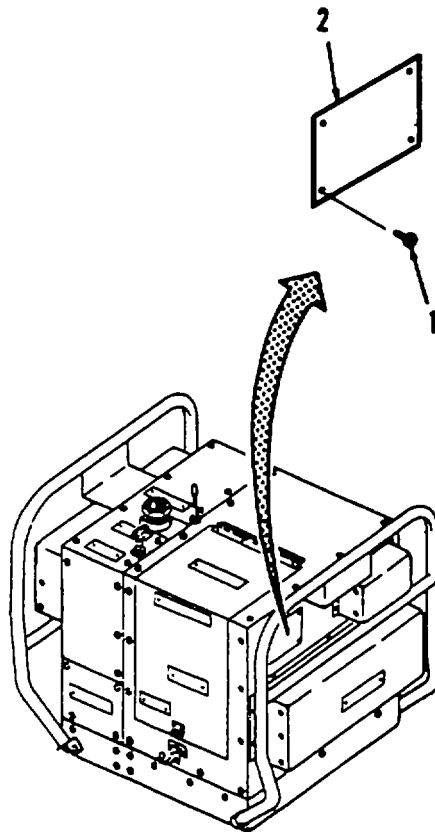

Figure 4-1. Ident Plates Replacement.

4-13. ROLL-OVER FRAME REPLACEMENT.

This Task Covers:

- a. Removal
 - b. Installation
-

Initial Setup:**Tools Required**

Tool Kit, General Mechanic's (Appendix B, Item 1)

Material's Required

None

Equipment Condition

DED pump assembly shut down and cool.

a. Removal (Refer to Figure 4-2).

- (1) Remove two screws (1), two screws (2), and outlet side roll-over frame (3) from unit.
- (2) Remove two screws (4), two screws (5), and inlet side roll-over frame (6) from unit.

b. Installation.

- (1) Install inlet side roll-over frame (6), two screws (5), and two screw (4).
- (2) Install outlet side roll-over frame (3), two screws (2), and two screw (1).

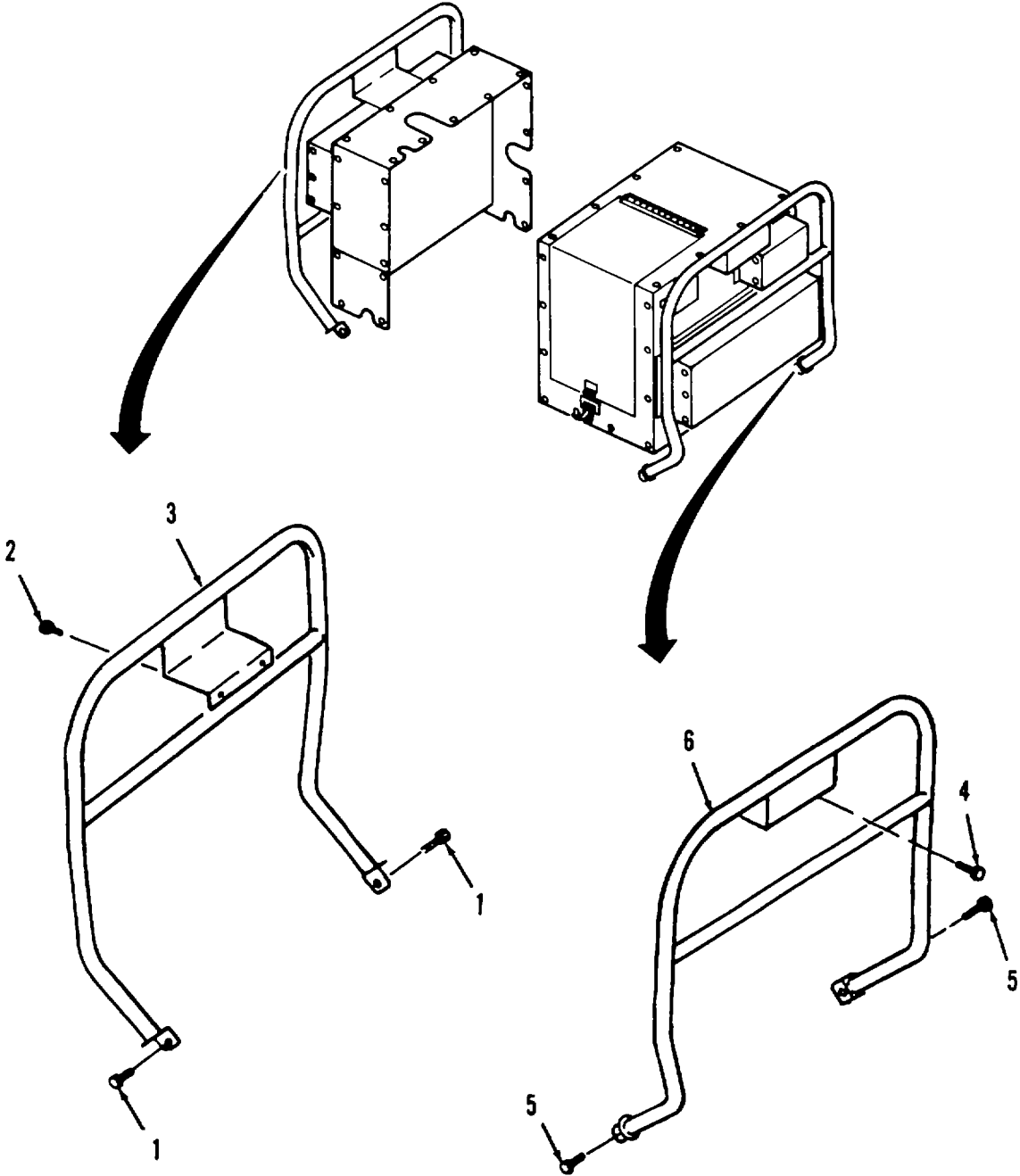

Figure 4-2. Roll-Over Frame Replacement.

4-14. COMPRESSION RELEASE HANDLE REPLACEMENT.

This Task Covers:

- a. Removal b. Installation
-

Initial Setup:**Tools Required**

Tool Kit, General Mechanic's (Appendix B, Item 1)

Material's Required

None

Equipment Condition

DED pump assembly shut down and cool.

a. Removal. (Refer to Figure 4-3).

- (1) Remove push on nut (1) from compression release handle (2).
- (2) Remove compression release handle (2) from the compression release lever (3) on the engine.
- (3) Remove compression release handle (2) from unit.
- (4) Remove molded cap (4) from compression release handle (2).
- (5) Remove grommet (5) from unit.

b. Installation.

- (1) Install grommet (5) into unit.
- (2) Install compression release handle (2) through grommet (5).
- (3) Install molded cap (4) onto compression release handle (2).
- (4) Insert compression release handle (2) into hole of compression release lever on engine.
- (5) Attach push on nut (1) to end of compression release handle (2) to hold handle onto engine compression release lever.

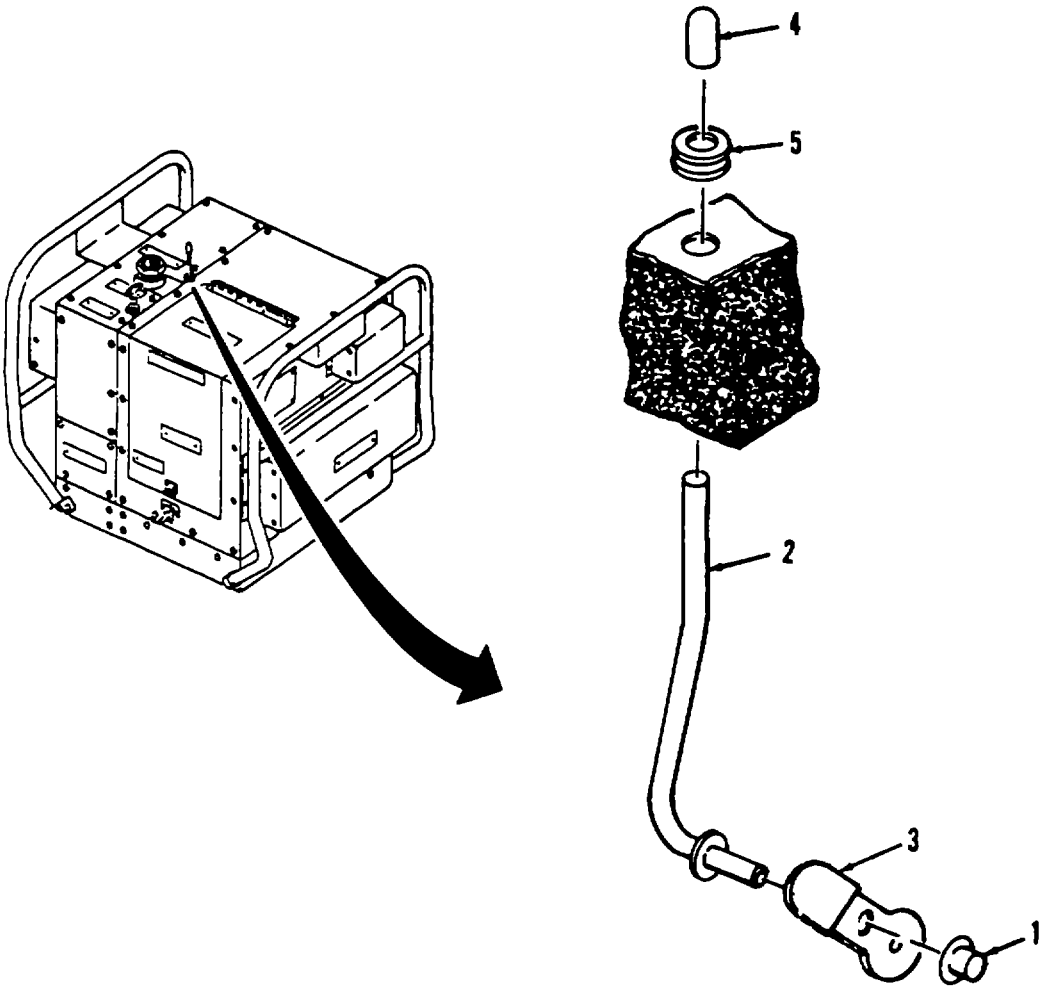

Figure 4-3. Compression Release Handle Replacement.

4-15. CONTROL ASSEMBLY REPLACEMENT.

This Task Covers:

- a. Removal b. Installation
-

Initial Setup:**Tools Required**

Tool Kit, General Mechanic's (Appendix B, Item 1)

Materials Required

None

Equipment Condition

DED pump assembly shut down and cool.

Outlet enclosure assembly tilted open (see para 4-23).

a. Removal (Refer to Figure 4-4).

- (1) Disconnect end of control assembly (1) from regulator handle (2) on engine.
- (2) Loosen nut (3) and slide nut and washer (4) down the length of the control assembly (1) cable and remove nut and washer.
- (3) Remove control assembly (1) through top of unit.

b. Installation.**NOTE**

Be sure throttle handle is fully inserted into cable housing before installing control assembly into unit.

- (1) Feed cable of control assembly (1) through top of unit.
- (2) Slide nut (3) and washer (4) up the length of the control assembly cable (1) and install and tighten nut onto control assembly.
- (3) Reconnect end of control cable onto regulator handle (2) of engine.

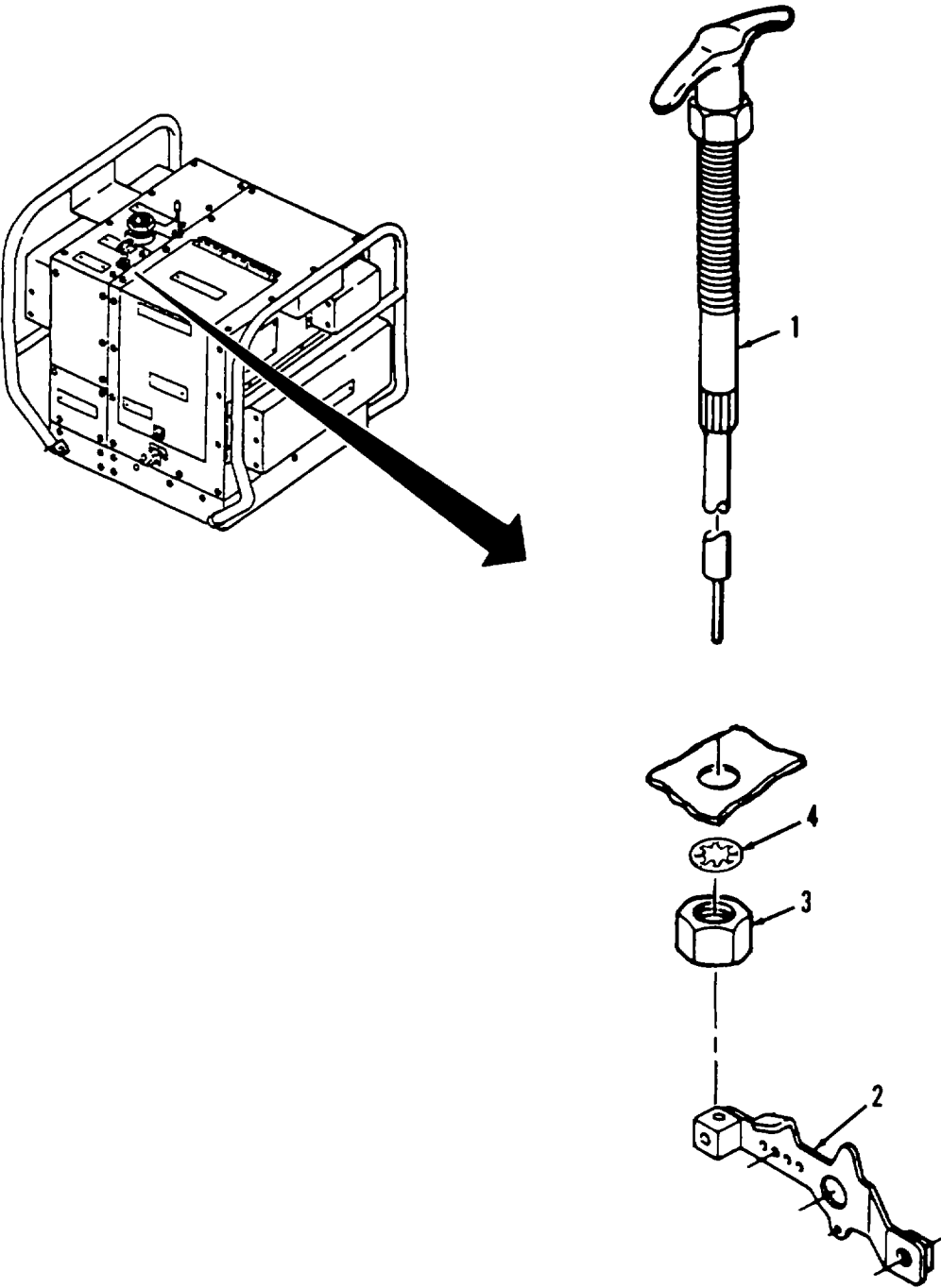

Figure 4-4. Control Assembly Replacement.

4-16. AIR INTAKE HOSE REPLACEMENT.

This Task Covers:

- a. Removal b. Installation
-

Initial Setup:**Tools Required**

Tool Kit, General Mechanic's (Appendix B, Item 1)

Material's Required

None

Equipment Condition

DED pump assembly shut down and cool.

a. Removal. (Refer to Figure 4-5).

- (1) Remove air intake hose (1) from intake tube of engine air cleaner.
- (2) Remove air intake hose (1) from internal baffle (2).

b. Installation.

- (1) Insert end of air intake hose (1) into opening in internal baffle (2).
- (2) Attach air intake hose (1) onto inlet tube of engine air cleaner.

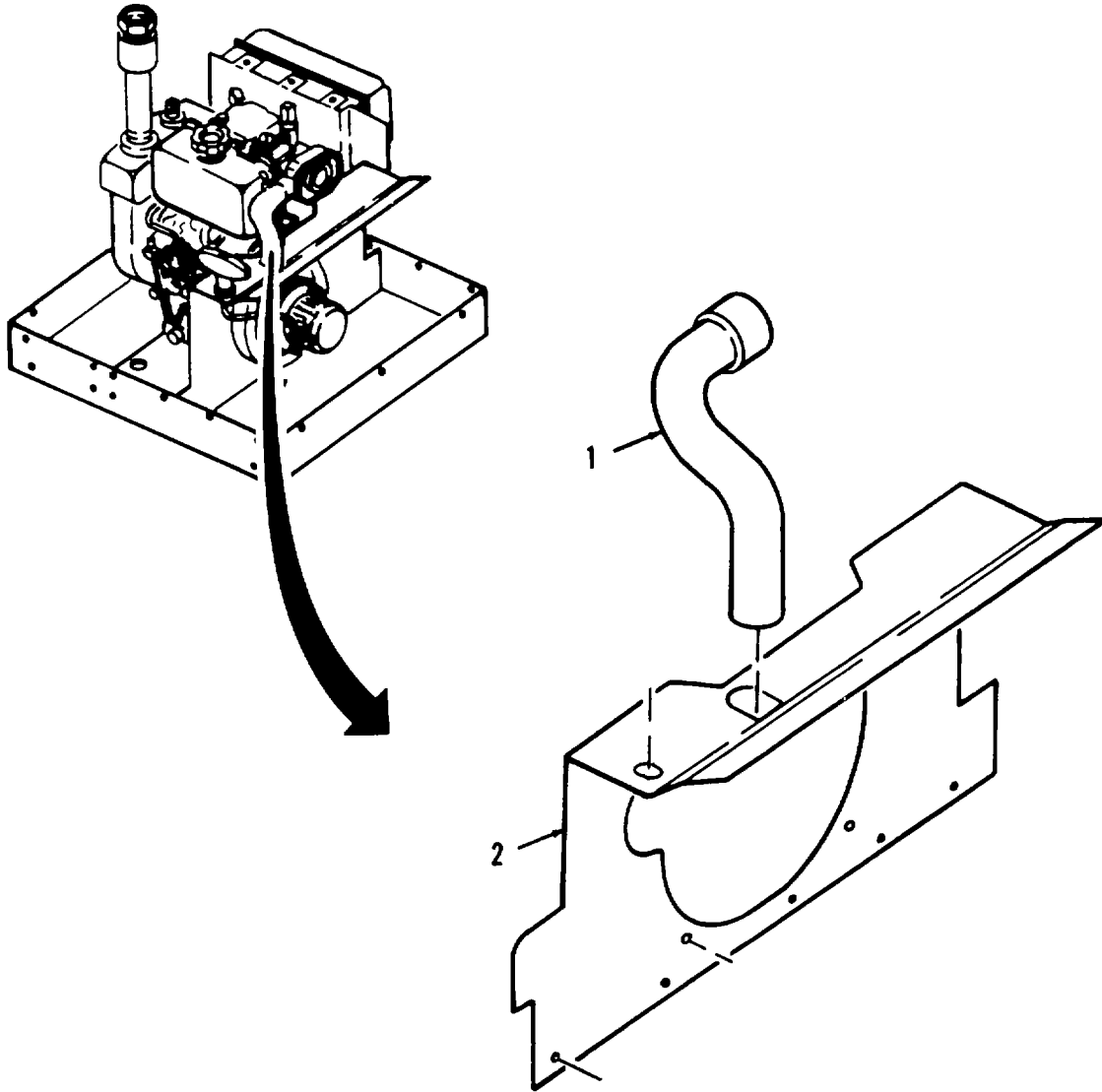

Figure 4-5. Air Intake Hose Replacement.

4-17. EXHAUST EXTENSION REPLACEMENT.

This Task Covers:

- a. Removal b. Installation
-

Initial Setup:**Tools Required**

Tool Kit, General Mechanic's (Appendix B, Item 1)

Materials Required

None

Equipment Condition

DED pump assembly shut down and cool.

Outlet enclosure assembly tilted open (see para 4-23).

a. Removal. (Refer to Figure 4-6).

- (1) Loosen and remove clamp (1).
- (2) Remove exhaust extension (2) from engine.

b. Installation.

- (1) Slide clamp (1) onto exhaust extension (2).
- (2) Install exhaust extension (2) onto engine exhaust silencer.
- (3) Tighten clamp (1) onto exhaust extension (2) to tighten extension onto engine exhaust silencer.

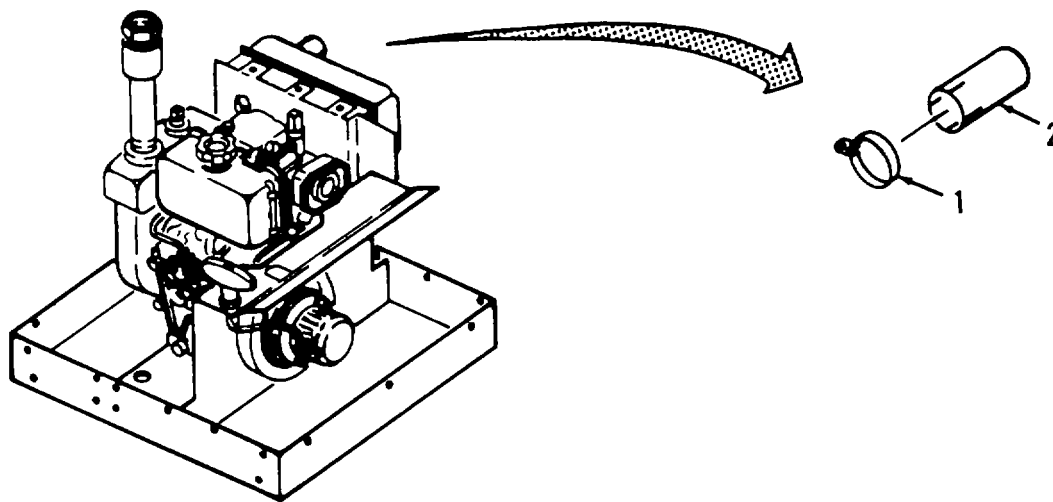

Figure 4-6. Exhaust Extension Replacement.

4-18. ACCESS COVER REPAIR AND REPLACEMENT.

This Task Covers:

- a. Removal b. Cleaning c. Inspection d. Repair e. Installation
-

Initial Setup:**Tools Required**

Tool Kit, General Mechanic's (Appendix B, Item 1)
Shears, Bent, Trimmers (Appendix B, Item 1)
Bit, Drill, .125 in. dia. (Appendix B, Item 2)

Materials Required

Cloth, Lint-Free (Appendix E, Item 1)
Brush, Medium Bristle (Appendix E, Item 2)
Solvent, Dry Cleaning (Appendix E, Item 3)

Equipment Condition

DED pump assembly shut down and cool.

a. Removal. (Refer to Figure 4-7).

- (1) Remove four screws (1) from access panel (2).
- (2) Remove access panel (2) from unit.
- (3) If foam insulation (3) is to be replaced, remove foam insulation (3) from access panel (2).
- (4) If access panel is being replaced, drill out two rivets (4) and ident plate (5).

b. Cleaning.

- (1) Remove all build up of dirt, oil, and debris from all surfaces.

WARNING

Serious injury can result in breathing fumes of dry cleaning solvent P-D-680, Type III. Serious injury or death can result from explosion of fumes from solvent. When using this solvent:

- Clean parts in a well ventilated area.
- Avoid inhalation of solvent fumes and prolonged exposure of skin to cleaning solvent. Wash exposed skin thoroughly.
- Do not use near open flame or excessive heat. Flash point of solvent is 100° F to 138° F (38° C to 59° C).
- Wear eye protection when blowing solvent from parts. Air pressure should not exceed 30 psig (2.1 kg/cm²).

(2) Clean all metallic parts with a clean soft cloth or a medium bristle brush, and cleaning solvent. Be sure that all gasket adhesive residue is removed if gasket material is being replaced.

(3) Allow parts to dry.

c. **Inspection.** Inspect access cover for cracks or corrosion.

d. **Repair.** Repair is limited to replacement of parts found defective during inspection.

e. **Installation.**

(1) Install ident plate (5) and two rivets, if removed.

(2) Install new foam insulation (3) if removed. Refer to Appendix F for manufacturing instructions.

(3) Install access panel (2) and four screws (1) onto unit.

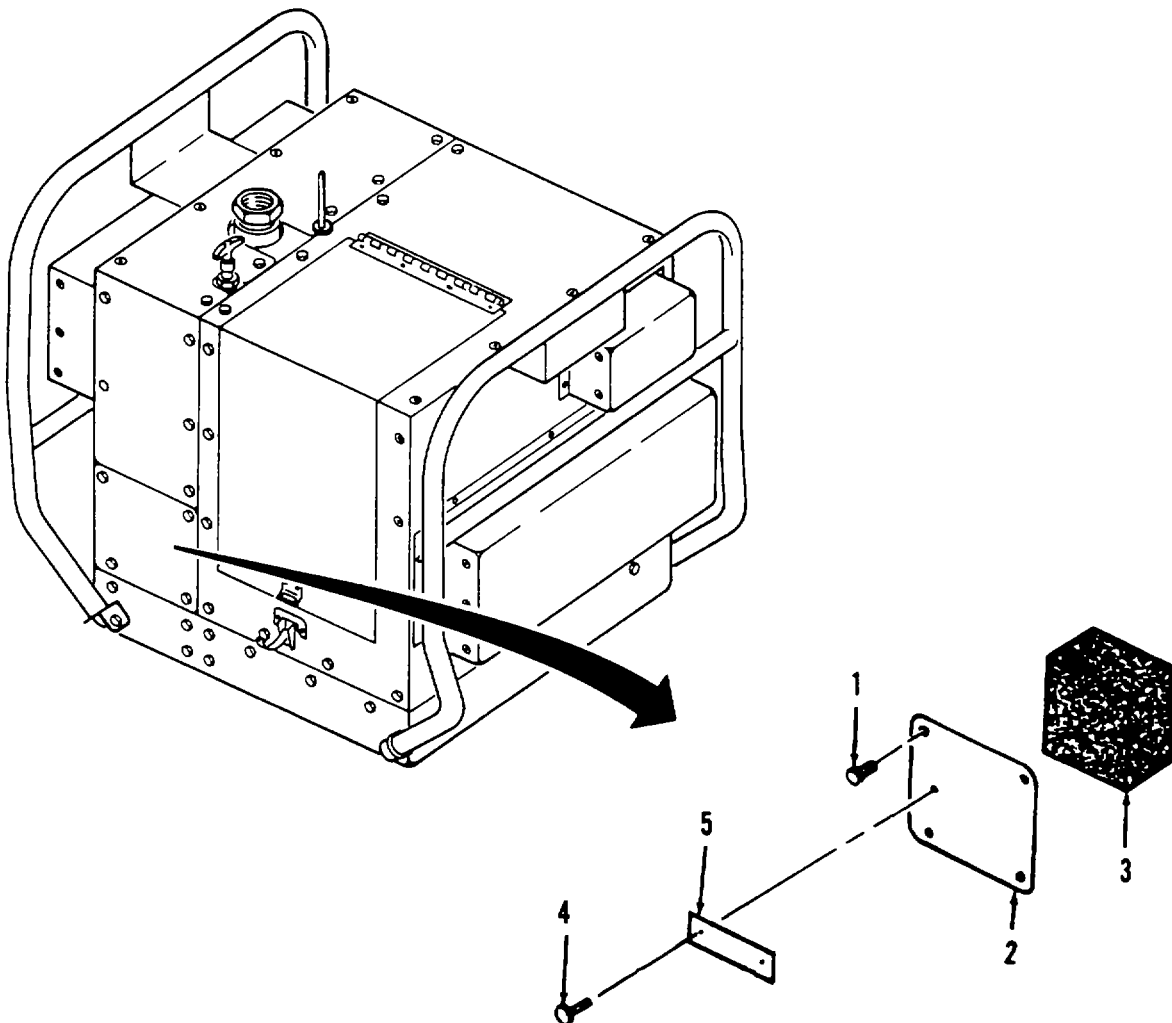

Figure 4-7. Access Cover Repair and Replacement.

4-19. PUMP DRAIN REPAIR AND REPLACEMENT.

This Task Covers:

- a. Removal b. Inspection c. Repair d. Installation
-

Initial Setup:**Tools Required**

Tool Kit, General Mechanic's (Appendix B, Item 1)

Materials Required

None

Equipment Condition

DED pump assembly shut down and cool.

Outlet enclosure assembly tilted open (see para 4-23).

a. Removal. (Refer to Figure 4-8).

- (1) Remove drain cock (1) from unit.
- (2) Remove coupling (2) and nipple (3) from pump (4).

b. Inspection.

- (1) Inspect drain cock for damage and for smooth operation of handle.
- (2) Check coupling and nipple for cracks and for damaged threads.

c. Repair. Repair is limited to replacement of parts found defective during inspection.**d. Installation.**

- (1) Install nipple (3) and coupling (2) onto pump (4).
- (2) Install drain cock (1) onto coupling (2).

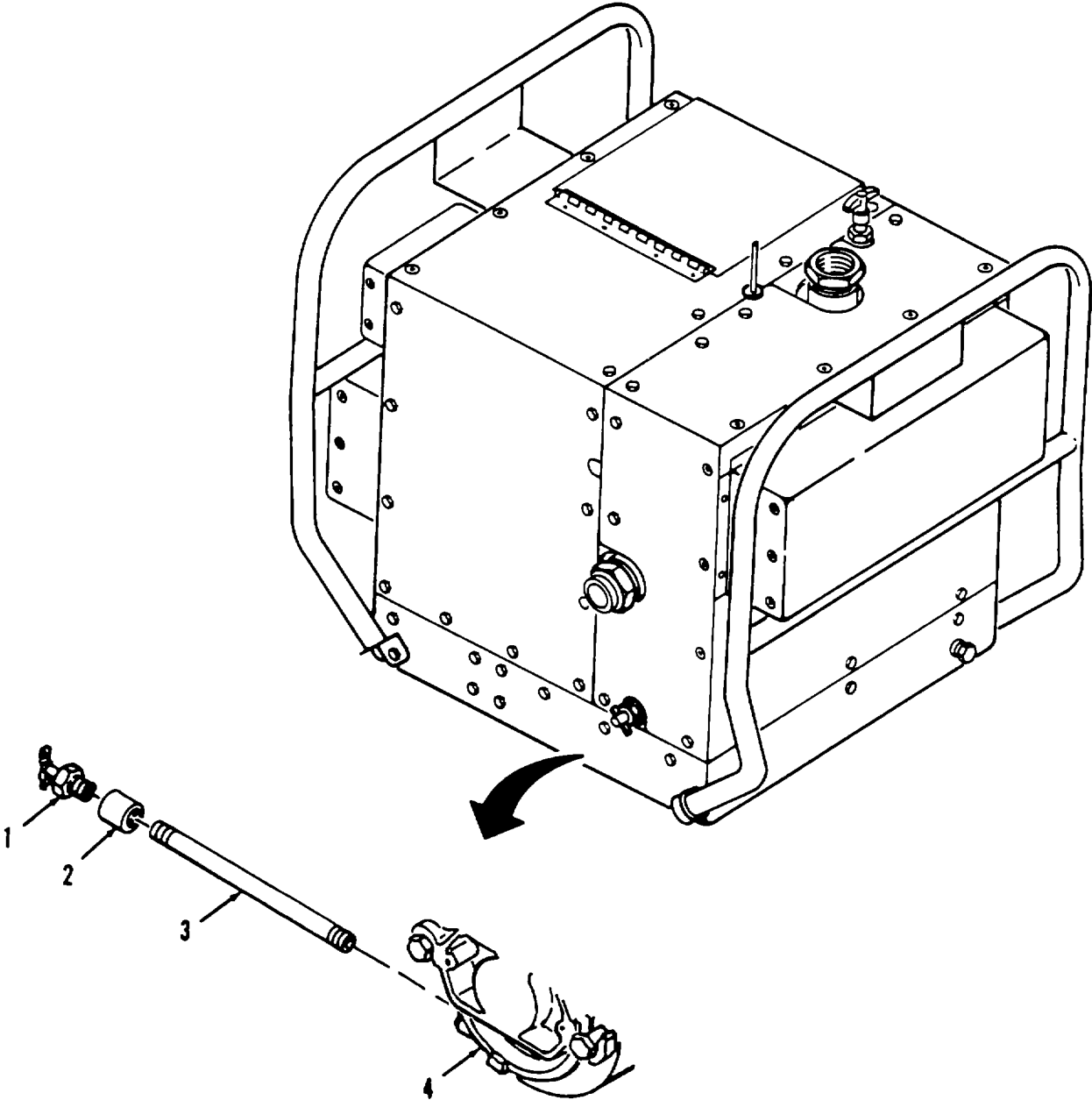

Figure 4-8. Pump Drain Repair and Replacement.

4-20. OIL DRAIN REPAIR AND REPLACEMENT.

This Task Covers:

- a. Removal b. Inspection c. Repair d. Installation
-

Initial Setup:**Tools Required**

Tool Kit, General Mechanic's (Appendix B, Item 1)
Pan, Drain (Appendix B, Item 2)
Shears, Bent, Trimmers (Appendix B, Item 2)

Material's Required

None

Equipment Condition

DED pump assembly shut down and cool.
Oil drained from engine (see Lubrication Order LO10-4320-316-12).
Outlet enclosure assembly tilted open (see para 4-23).

a. Removal. (Refer to Figure 4-9).

- (1) Remove plug (1) from hose fitting (2).
- (2) Remove hose fitting (3) from engine.
- (3) Remove hose fitting (2) and hose fitting (3) from hose (4).

b. Inspection.

- (1) Inspect all threads for damage.
- (2) Check hose fittings for cracks and damaged threads.
- (3) Check hose for cuts and leaks.

c. Repair. Repair is limited to replacement of parts found defective during inspection.**d. Installation.**

- (1) Install hose fitting (3) and hose fitting (2) onto hose (4).
- (2) Install hose fitting (3) into engine.
- (3) Install plug (1) into hose fitting (2).
- (4) Insert installed plug (1) through enclosure.

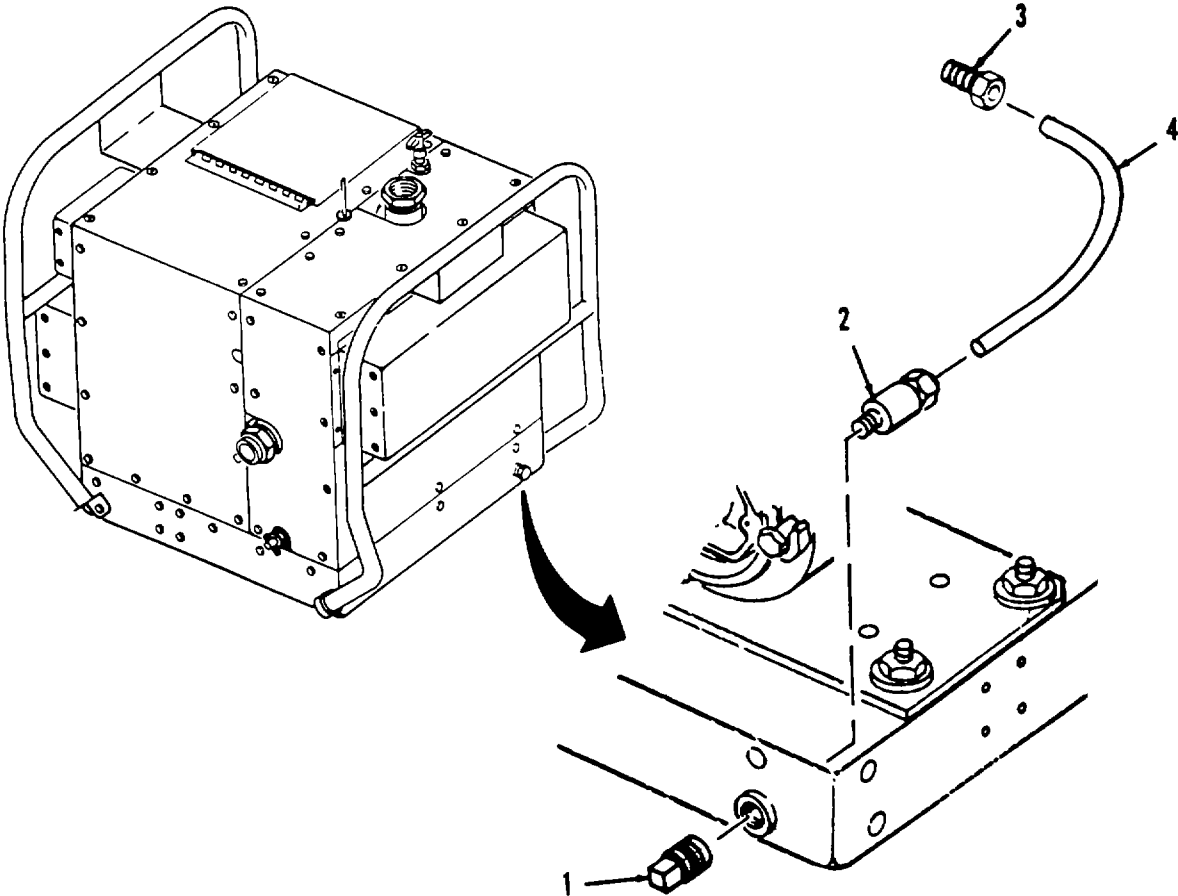

Figure 4-9. Oil Drain Repair and Replacement.

4-21. BAFFLES REPLACEMENT.

This Task Covers:

- a. Removal b. Installation
-

Initial Setup:**Tools Required**

Tool Kit, General Mechanic's (Appendix B, Item 1)

Materials Required

None

Equipment Condition

DED pump assembly shut down and cool.

Air intake hose removed (see paragraph 4-16).

Outlet enclosure assembly removed (see paragraph 4-23).

a. Removal. (Refer to Figure 4-10).

- (1) Remove three screws (1) and muffler baffle assembly (2).
- (2) Pull the rope T-handle (3) slowly, turning the crankshaft until approximately two feet of pull rope (4) is exposed.
- (3) Grasp the rope (4) firmly and pull the knot (5) in the rope about six inches out of the T-handle (3).

CAUTION

With knot untied do not allow rope to rewind into the starter assembly.

- (4) Untie the knot (5) and remove T-handle (3).
- (5) Pass the rope (4) through the grommet (6) in baffle (5). Slip the T-handle (3) onto the rope (4) and tie knot (7) in rope.
- (6) Allow the rope (4) to rewind until the T-handle (3) seats on the recoil start assembly.
- (7) Remove four screws (8) and baffle (5).

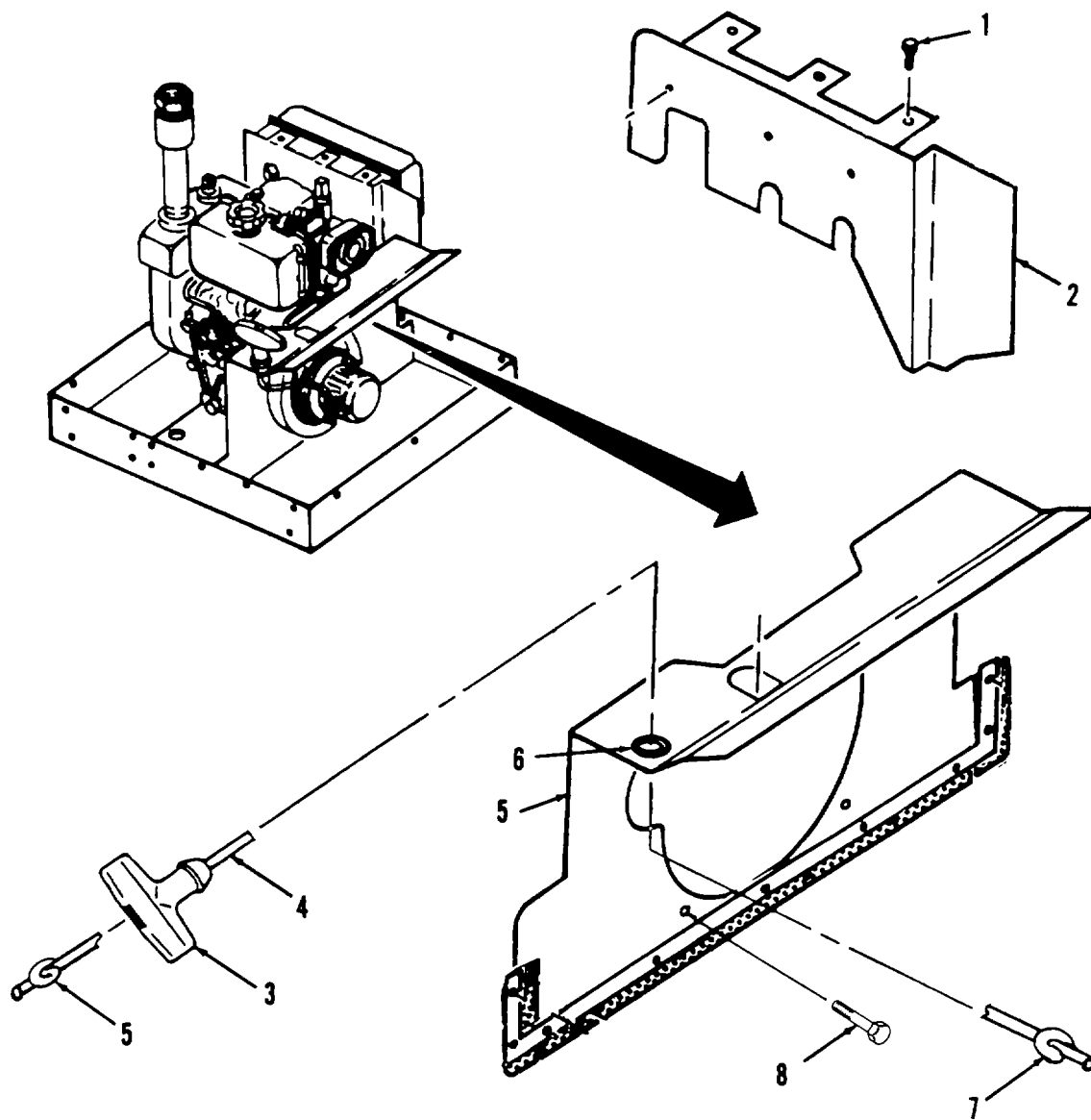

Figure 4-10. Baffles Replacement.

4-21. BAFFLES REPLACEMENT. - Continued.**b. Installation**

- (1) Install baffle (5) and four screws (8).
- (2) Pull the rope T-handle (3) slowly, turning the crankshaft until approximately two feet of pull rope (4) is exposed.
- (3) Grasp the rope (4) firmly and pull the knot (7) in the rope about six inches out of the T-handle (3).

CAUTION

With knot untied do not allow rope to rewind into the starter assembly.

- (4) Untie the knot (7).
- (5) Slip the T-handle (3) off of the rope (4) and retie the knot.
- (6) Feed the rope (4) through the baffle grommet (6).
- (7) Install T-handle (3) on the rope (4). Thread enough rope through the T-handle to make knot (5).
- (8) Pull rope (4) against the hole in the T-handle (3). Stuff excess rope into the T-handle slot.
- (9) Install muffler baffle assembly (2) and three screws (1).

4-22. ENCLOSURE ASSEMBLY, INLET SIDE REPAIR AND REPLACEMENT.

This Task Covers:

- a. Removal b. Disassembly c. Cleaning d. Repair e. Assembly f. Installation
-

Initial Setup:**Tools Required**

Tool Kit, General Mechanic's (Appendix B, Item 1)
Drill, Hand Portable (Appendix B, Item 2)
Bit, Drill, .125 in. dia. (Appendix B, Item 2)
Riveter, Blind, Hand (Appendix B, Item 5)
Shears, Bent, Trimmers (Appendix B, Item 2)

Materials Required

Cloth, Lint-Free (Appendix E, Item 1)
Brush, Medium Bristle (Appendix E, Item 2)
Solvent, Dry Cleaning (Appendix E, Item 3)

Equipment Condition

DED pump assembly shut down and cool.

NOTE

If inlet enclosure assembly is being removed for maintenance access only, do not remove roll-over frames.

Roll-over frame removed (see paragraph 4-13).
Access cover removed (see paragraph 4-18).

a. Removal. (Refer to Figure 4-11).

- (1) Remove twenty-one screws (1).
- (2) Remove inlet enclosure assembly (2) from unit.

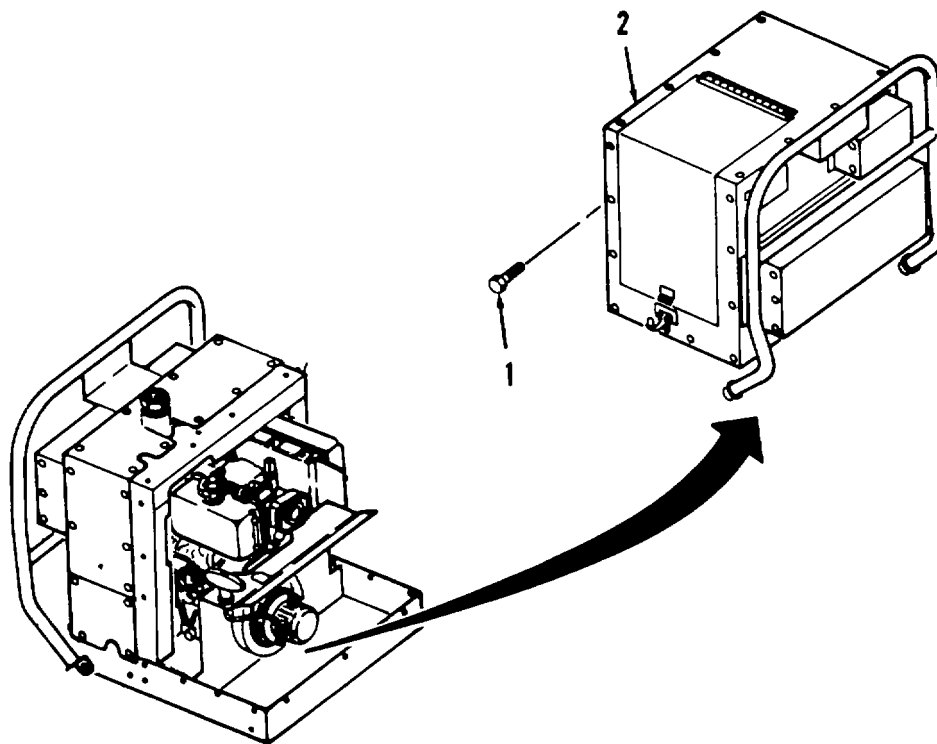

Figure 4-11. Enclosure Assembly, Inlet Side Removal.

b. Disassembly. (Refer to Figure 4-12).

- (1) Drill out and remove four rivets (1) from door (2).
- (2) Drill out and remove four rivets (1) and remove hinge (3).
- (3) Drill out and remove two rivets (4) and two rivets (5).
- (4) Remove catch strike (6) and clamping catch (7) from door (2).
- (5) Drill out and remove ten rivets (8) and sheet (9) from sheet (10).
- (6) Drill out and remove seven rivets (11) and sheet (12) from sheet (9).
- (7) Drill out and remove eight rivets (13) and sheet (14) from sheet (9).
- (8) If foam insulation is to be replaced, remove foam insulation as required.

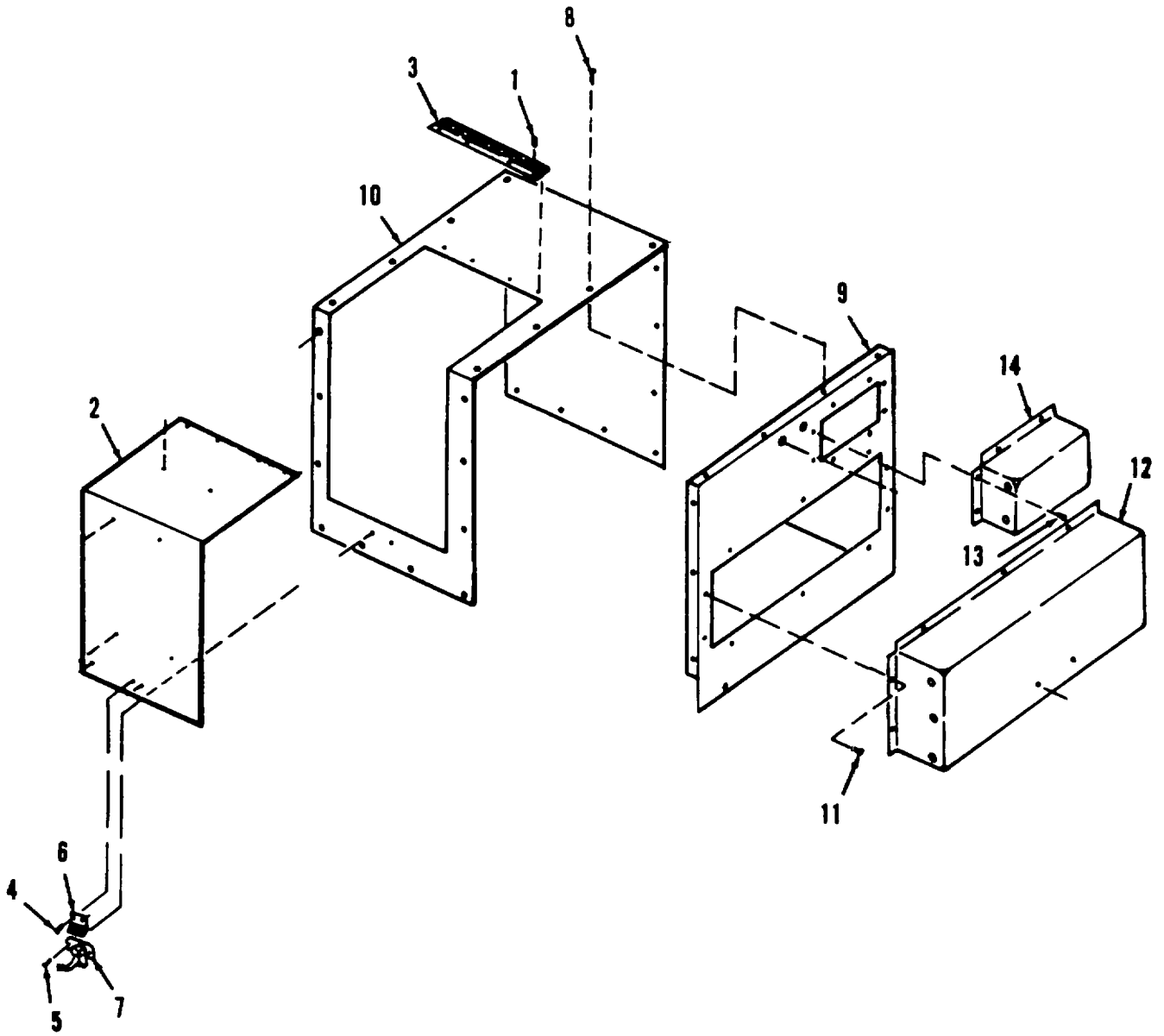

Figure 4-12. Enclosure Assembly, Inlet Side Disassembly.

c. Cleaning.

- (1) Remove all build up of dirt, oil, and debris from all surfaces.

WARNING

Serious injury can result in breathing fumes of dry cleaning solvent P-D-680, Type III. Serious injury or death can result from explosion of fumes from solvent. When using this solvent:

- Clean parts in a well ventilated area.
 - Avoid inhalation of solvent fumes and prolonged exposure of skin to cleaning solvent. Wash exposed skin thoroughly.
 - Do not use near open flame or excessive heat. Flash point of solvent is 100° F to 138° F (38° C to 59° C).
 - Wear eye protection when blowing solvent from parts. Air pressure should not exceed 30 psig (2.1 kg/cm²).
- (2) Clean all metallic parts with a clean soft cloth or a medium bristle brush, and cleaning solvent. Be sure that all gasket adhesive residue is removed if gasket material is being replaced.
 - (3) Allow parts to dry.

d. Repair. Repair is limited to replacement of parts found defective during inspection.

e. Assembly. (Refer to Figure 4-12.)

- (1) If foam insulation was removed, replace foam insulation. Refer to Appendix F for manufacturing instructions.
- (2) Install eight rivets (13) and sheet (14) onto sheet (9).
- (3) Install seven rivets (11) and sheet (12) onto sheet (9).
- (4) Install ten rivets (8) and sheet (9) onto sheet (10).
- (5) Install two rivets (5) and clamping catch onto sheet (10).
- (6) Install two rivets (4) and catch strike (6) onto door (2).
- (7) Install four rivets (1) and hinge (3) onto door (2).
- (8) Install four rivets (1) and door (2) onto sheet (10).

f. Installation. (Refer to Figure 4-11).

- (1) Place inlet enclosure assembly (2) into position on unit.
- (2) Install twenty-one screws (1).

4-23. ENCLOSURE ASSEMBLY, OUTLET REPAIR AND REPLACEMENT.

This Task Covers:

- a. Removal b. Disassembly c. Cleaning d. Repair e. Assembly f. Installation
-

Initial Setup:**Tools Required**

Tool Kit, General Mechanic's (Appendix B, Item 1)
Drill, Hand Portable (Appendix B, Item 2)
Riveter, Blind, Hand (Appendix B, Item 5)
Bit, Drill, .125 in. dia. (Appendix B, Item 2)
Shears, Bent, Trimmers (Appendix B, Item 2)

Material's Required

Cloth, Lint-Free (Appendix E, Item 1)
Brush, Medium Bristle (Appendix E, Item 2)
Solvent, Dry Cleaning (Appendix E, Item 3)

Equipment Condition

DED pump assembly shut down and cool.

NOTE

If outlet enclosure assembly is being removed for maintenance access only, do not remove roll-over frames.

Roll-over handles removed (see paragraph 4-13).
Access cover removed (see paragraph 4-18).
Inlet enclosure assembly removed (see paragraph 4-22).
Compression release handle removed (see paragraph 4-14).
Throttle control assembly removed (see paragraph 4-15).

a. Removal. (Refer to Figure 4-13).

- (1) Remove nineteen screws (1).
- (2) Remove outlet enclosure assembly (2) from unit.
- (3) Remove four screws (3) and sheet (4).

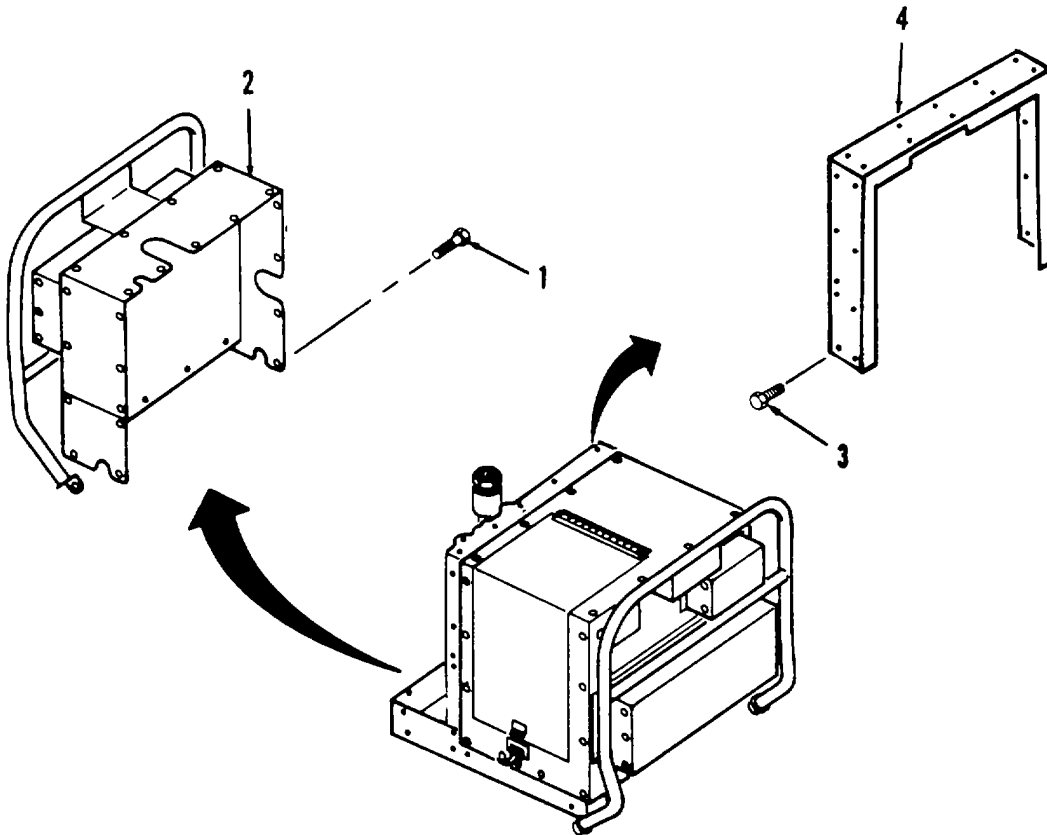

Figure 4-13. Enclosure Assembly, Outlet Side Removal.

b. Disassembly. (Refer to Figure 4-14).

- (1) Drill out and remove seven rivets (1).
- (2) Remove sheet (2) from sheet (3).
- (3) Drill out and remove eleven rivets (4).
- (4) Remove sheet (5) from sheet (3).
- (5) If foam insulation is to be replaced, remove foam insulation (6) as required.

4-23. ENCLOSURE ASSEMBLY, OUTLET REPAIR AND REPLACEMENT. Continued.

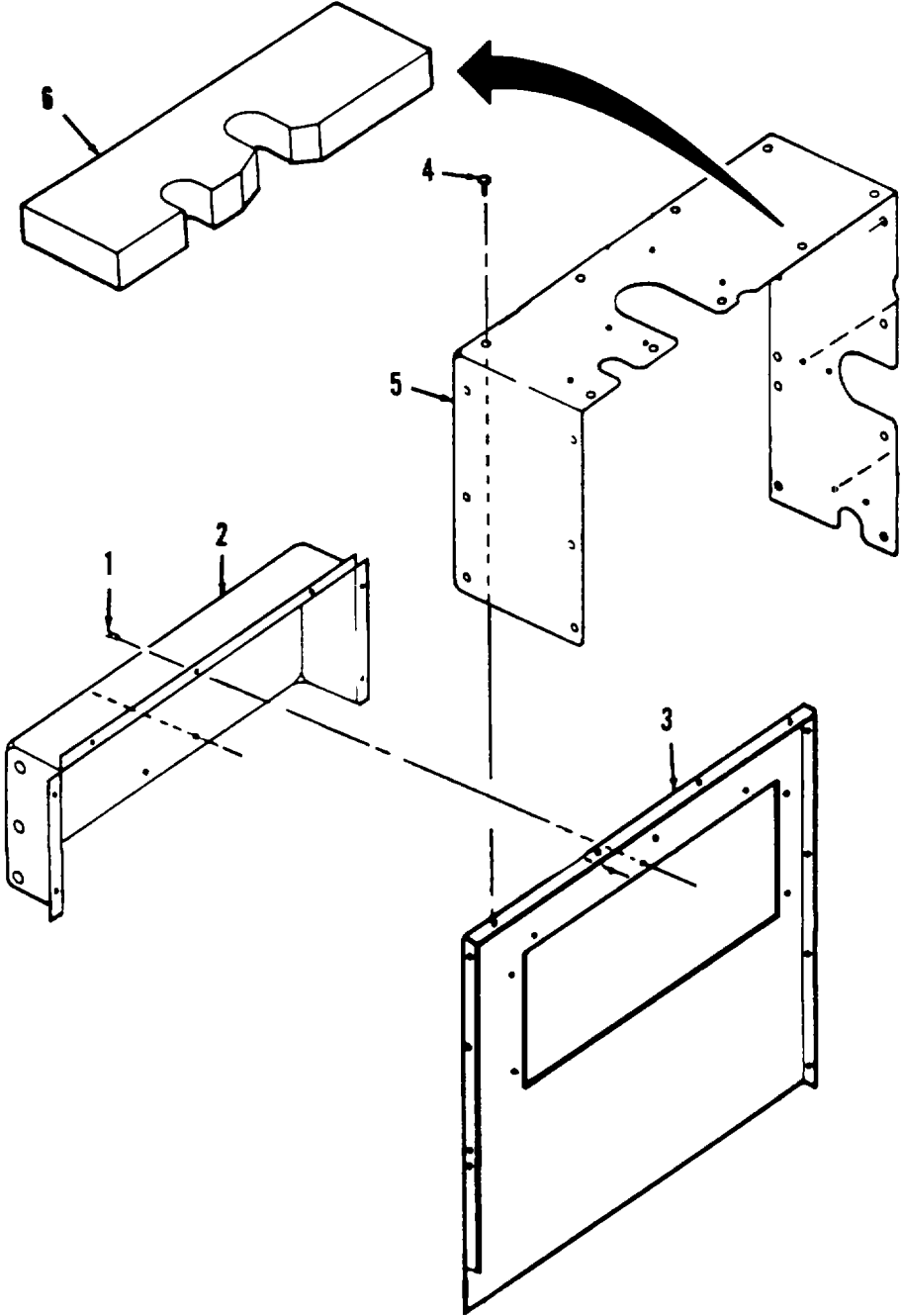

Figure 4-14. Enclosure Assembly, Outlet Side Disassembly.

c. Cleaning.

- (1) Remove all build up of dirt, oil, and debris from all surfaces.

WARNING

Serious injury can result in breathing fumes of dry cleaning solvent P-D-680, Type III. Serious injury or death can result from explosion of fumes from solvent. When using this solvent:

- Clean parts in a well ventilated area.
- Avoid inhalation of solvent fumes and prolonged exposure of skin to cleaning solvent. Wash exposed skin thoroughly.
- Do not use near open flame or excessive heat. Flash point of solvent is 100° F to 138° F (38° C to 59° C).
- Wear eye protection when blowing solvent from parts. Air pressure should not exceed 30 psig (2.1 kg/cm²).

- (2) Clean all metallic parts with a clean soft cloth or a medium bristle brush, and cleaning solvent. Be sure that all gasket adhesive residue is removed if gasket material is being replaced.

- (3) Allow parts to dry.

d. Repair. Repair is limited to replacement of parts found defective during inspection.

e. Assembly. (Refer to Figure 4-14.)

- (1) If foam insulation (6) was removed, replace foam insulation. Refer to Appendix F for manufacturing instructions.
- (2) Place sheet (5) into position on sheet (3) and install eleven rivets (4).
- (3) Place sheet (2) into position on sheet (3) and install seven rivets (1).

f. Installation. (Refer to Figure 4-13).

- (1) Install sheet (4) and four screws (3).
- (2) Place outlet enclosure assembly (3) into position on unit and install twelve screws (2).
- (3) Install seven screws (1).
- (4) Install access cover (see paragraph 4-18).
- (5) Install roll-over frames (see paragraph 4-13).

4-24. PUMP INLET/OUTLET PIPING AND SUCTION FLANGE ASSEMBLY REPAIR AND REPLACEMENT.

This Task Covers:

- a. Removal b. Cleaning c. Inspection d. Repair e. Installation
-

Initial Setup:

Tools Required

Tool Kit, General Mechanic's (Appendix B, Item 1)

Materials Required

Cloth, Lint-Free (Appendix E, Item 1)
 Brush, Medium Bristle (Appendix E, Item 2)
 Solvent, Dry Cleaning (Appendix E, Item 3)
 Detergent, General Purpose (Appendix E, Item 10)
 Tape Anti-seize (Appendix E, Item 11)
 Gasket, (Refer to TM10-4320-316-24P)

Equipment Condition

DED pump assembly shut down and cool.
 Inlet enclosure removed (see paragraph 4-22).
 Outlet enclosure removed (see paragraph 4-23).

a. Removal (Refer to Figure 4-15)

(1) Remove hose adapter (1), coupling (2), and nipple (3) from pump (4) inlet.

(2) Remove hose adapter (5), gasket (6), coupling (7), and nipple (8) from pump (9) outlet.

(3) Remove two nuts (10) and two lock washers (11) from pump assembly (12).

(4) Remove suction flange (13) and gasket (14) from pump assembly (12).

(5) Remove screw (15), check valve weight (16), and check valve weight (17) from gasket (18).

Discard gasket.

b. Cleaning.

(1) Remove all build up of dirt, oil, and debris from all surfaces.

WARNING

Serious injury can result in breathing fumes of dry cleaning solvent P-D-680, Type III. Serious injury or death can result from explosion of fumes from solvent. When using this solvent:

- Clean parts in a well ventilated area.
- Avoid inhalation of solvent fumes and prolonged exposure of skin to cleaning solvent. Wash exposed skin thoroughly.
- Do not use near open flame or excessive heat. Flash point of solvent is 100° F to 138° F (38° C to 59° C).
- Wear eye protection when blowing solvent from parts. Air pressure should not exceed 30 psig (2.1 kg/cm²).

- (2) Clean all metallic parts with a clean soft cloth or a medium bristle brush, and cleaning solvent.
- (3) Allow parts to dry.

c. Inspection.

- (1) Inspect all threads for damage.
- (2) Check hose adapters, couplings, and nipples for cracks.

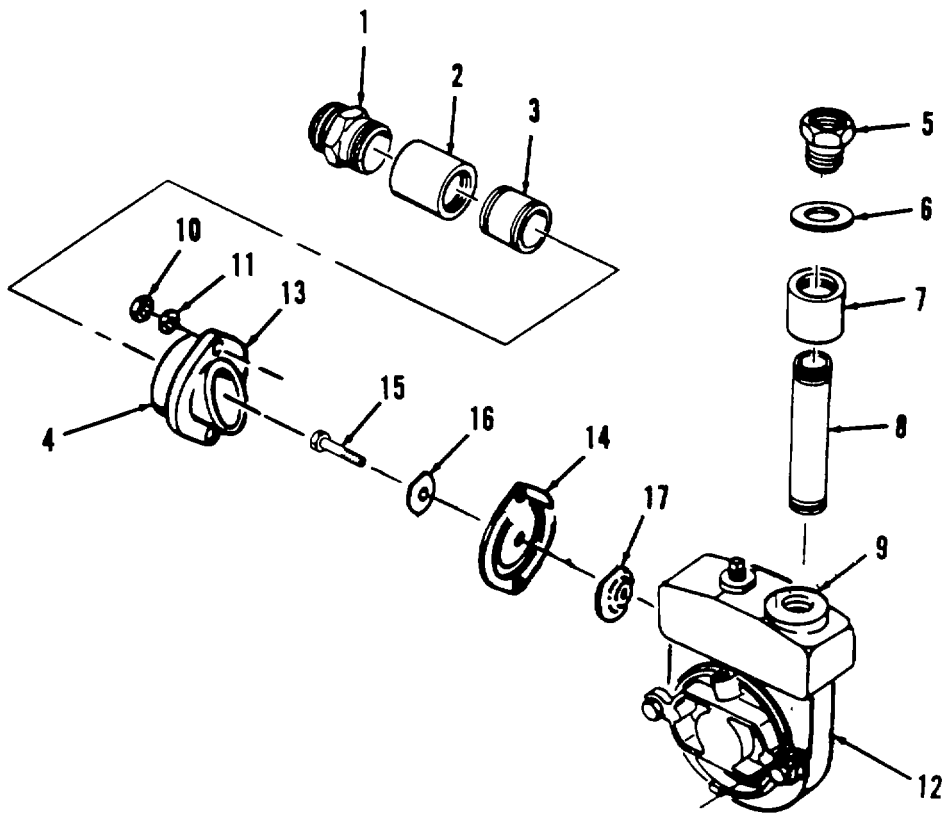

Figure 4-15. Pump Inlet/Outlet Piping Repair and Suction Flange Assembly Repair and Replacement.

4-24. PUMP INLET/OUTLET PIPING AND SUCTION FLANGE ASSEMBLY REPAIR AND REPLACEMENT. - Continued.

d. **Repair.** Repair is limited to replacement of parts found defective during inspection.

e. **Installation.**

- (1) Install check valve weight (17), check valve weight (16), and screw (15) onto new gasket (18).

NOTE

Hinged area of gasket faces the top stud. Large weight should face the pump.

NOTE

Install suction flange with tapered, protruding edge facing bottom.

- (2) Install gasket (14), suction flange (13), two lock washers (11), and two nuts (10) onto pump (12).

NOTE

Always wrap anti-seize tape around threads in the same direction as threads will rotate during installation.

- (3) Wrap anti-seize tape around pipe threads and install nipple (8), coupling (7), gasket (6), and hose adapter (5) onto pump (9) outlet.
- (4) Wrap anti-seize tape around pipe threads and install nipple (3), coupling (2), and hose adapter (1) onto pump (4) inlet.

4-25. BOTTOM PAN FRAME REPAIR AND REPLACEMENT.

This Task Covers:

- a. Removal b. Cleaning c. Inspection d. Repair e. Installation
-

Initial Setup:**Tools Required**

Tool Kit, General Mechanic's (Appendix B, Item 1)

Material's Required

Cloth, Lint-Free (Appendix E, Item 1)

Brush, Medium Bristle (Appendix E, Item 2)

Solvent, Dry Cleaning (Appendix E, Item 3)

Equipment Condition

DED pump assembly shut down and cool.

Inlet enclosure removed (see paragraph 4-22).

Outlet enclosure removed (see paragraph 4-23).

a. Removal (Refer to Figure 4-16).

(1) Remove four screws (1), eight shock mounts (2), four flat washers (3), and four lock nuts (4).

(2) Remove bottom pan frame (5).

(3) Remove four screws (13), four flat washers (14), and four bumpers (15) from bottom pan frame

(5).

b. Cleaning

(1) Remove all build up of dirt, oil, and debris from all surfaces.

WARNING

Serious injury can result in breathing fumes of dry cleaning solvent P-D-680, Type III. Serious injury or death can result from explosion of fumes from solvent. When using this solvent:

- Clean parts in a well ventilated area.
- Avoid inhalation of solvent fumes and prolonged exposure of skin to cleaning solvent. Wash exposed skin thoroughly.
- Do not use near open flame or excessive heat. Flash point of solvent is 100° F to 138° F (38° C to 59° C).
- Wear eye protection when blowing solvent from parts. Air pressure should not exceed 30 psig (2.1 kg/cm²).

(2) Clean all metallic parts with a clean soft cloth or a medium bristle brush, and cleaning solvent.

(3) Allow parts to dry.

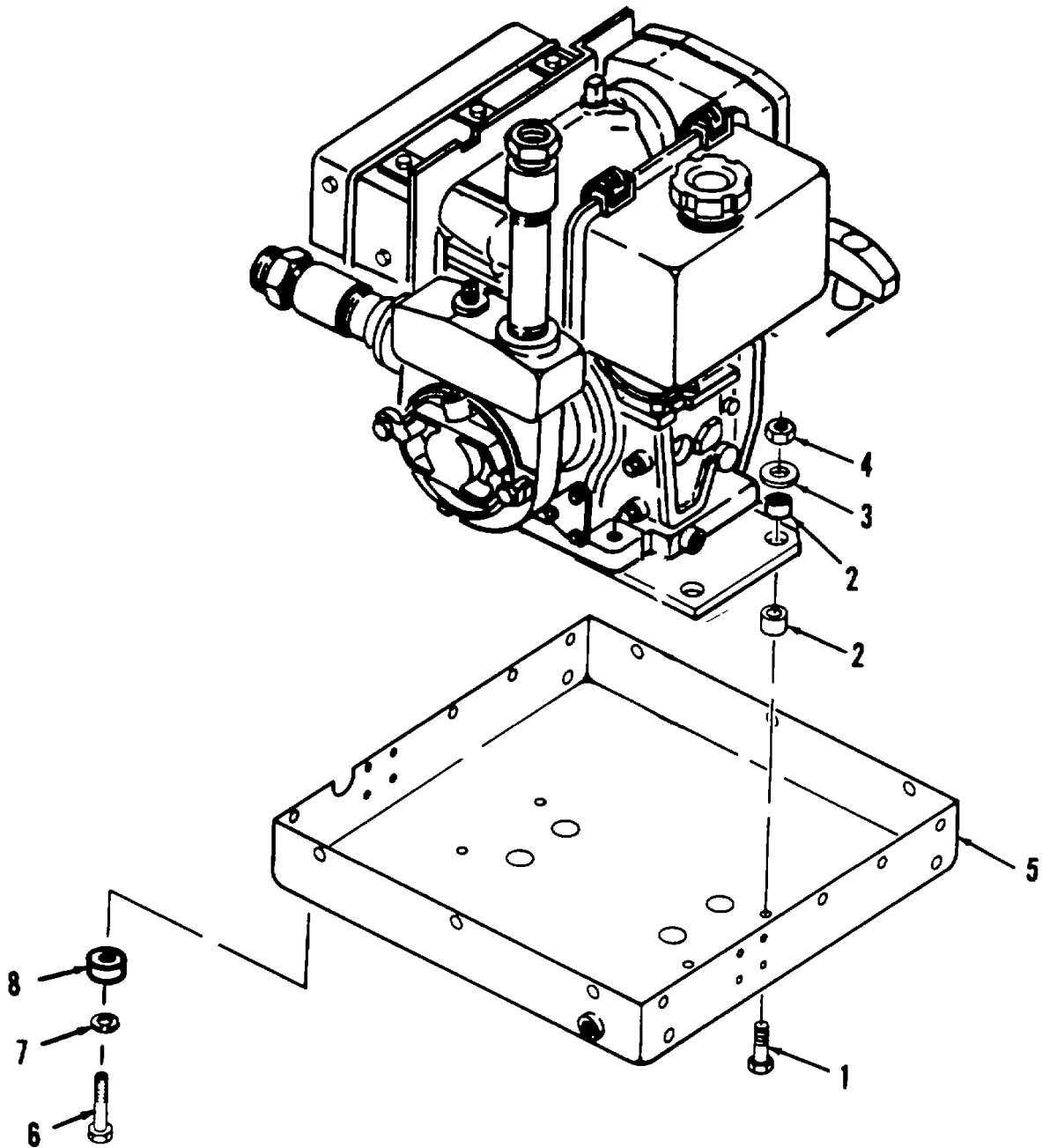

Figure 4-16. Bottom Pan Frame Repair and Replacement.
4-51

4-25. BOTTOM PAN FRAME REPAIR AND REPLACEMENT. - Continued.

c. Inspection.

- (1) Inspect all fastener threads for damage.
- (2) Check bottom pan frame for cracks and dents.

- (3) Inspect bumpers and shock for damage.

d. Repair. Repair is limited to replacement of parts found defective during inspection.

e. Installation.

- (1) Install four bumpers (15), four flat washers (14), and four screws (13), onto bottom pan frame (5).
- (2) Install bottom pan frame (5).

- (3) Install four lock nuts (4), four flat washers (3), eight shock mounts (2) and four screws (1).

4-26. PUMP ASSEMBLY REPAIR AND REPLACEMENT.

This Task Covers:

- a. Removal b. Cleaning c. Inspection d. Repair e. Installation
-

Initial Setup:**Tools Required**

Tool Kit, General Mechanic's (Appendix B, item 1)

Material's Required

Detergent, General Purpose (Appendix E, Item 10)
 Cloth, Lint-Free (Appendix E, Item 1)
 Brush, Medium Bristle (Appendix E, Item 2)
 Silicone Compound (Appendix E, Item 4)
 Packing, (Refer to TM 10-4320-316-24P)
 Lock Washer (Refer to TM 10-4320-316-24P)
 Lock Washers (Refer to TM 10-4320-316-24P)

Equipment Condition

DED pump assembly shut down and cool.
 Outlet enclosure assembly tilted open (see paragraph 4-23).

a. Removal. (Refer to Figure 4-17).

- (1) Remove two shoulder bolts (1), cover plate (2), and packing (3). Discard packing.
- (2) Remove nut (4), setscrew (5), and plastic washer (6).
- (3) Remove peeler (7) from pump.
- (4) Remove screw (8), lock washer (9), and washer (10). Discard lock washer.

NOTE

It may be necessary to use a small wood block and the rubber mallet to tap the impeller vanes so impeller breaks loose.

- (5) Remove impeller (11)
- (6) Remove three screws (12), and wear plate (13).
- (7) Tap out adapter shaft (14), two keys (15), and O-ring (16).
- (8) Remove shim stock (17).
- (9) Remove three screws (18), three lock washers (19), and pump body (20) from engine. Discard lock washers.
- (10) Remove plug (21) from pump body (20).
- (11) Remove two studs (22) from pump body (20).

NOTE

Do not remove shaft seal unless it is being replaced.

(12) Tap out shaft seal (23)

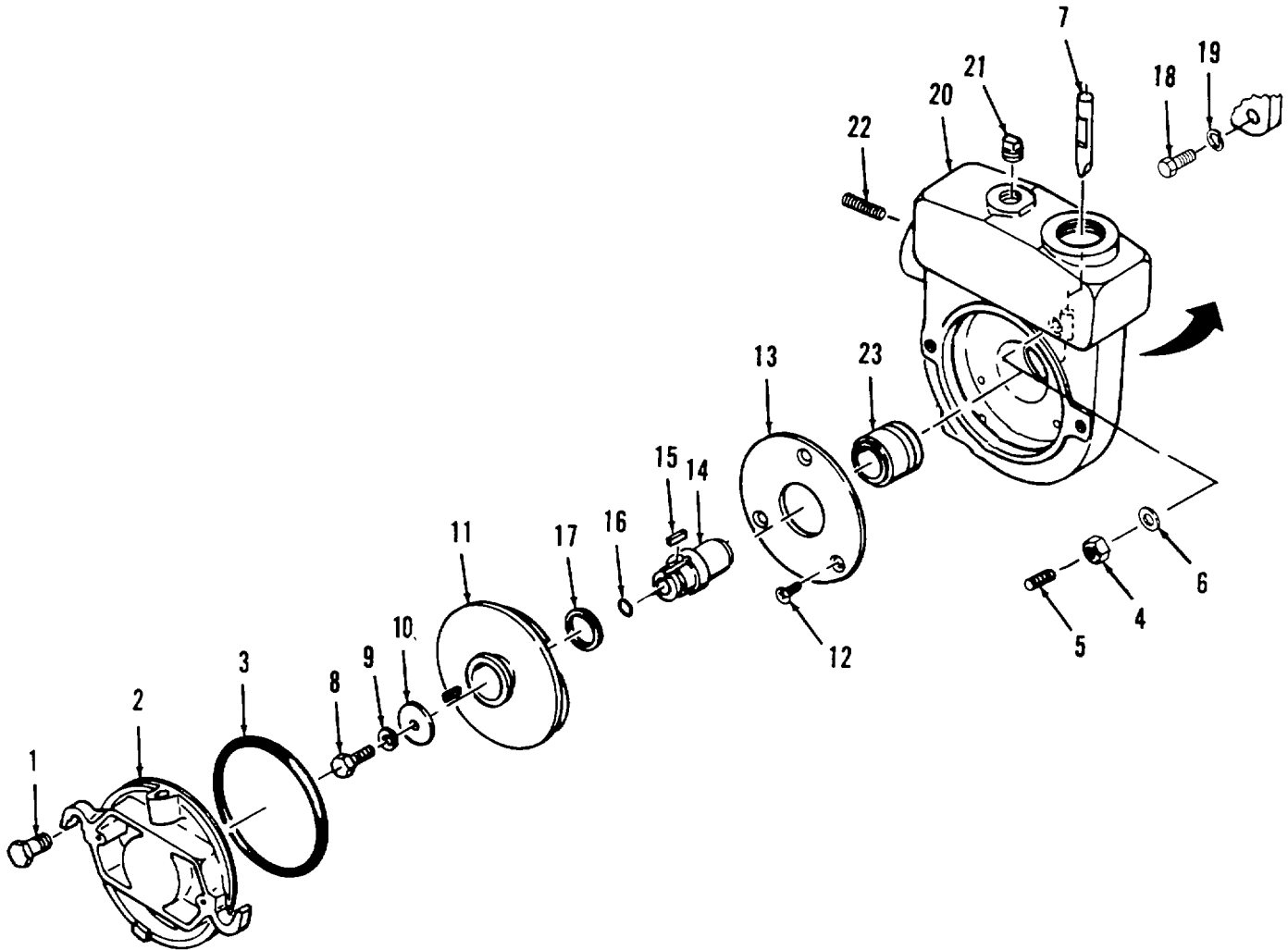

Figure 4-17. Pump Assembly Repair and Replacement.

4-26. PUMP ASSEMBLY REPAIR AND REPLACEMENT. - Continued.**b. Inspection.**

- (1) Inspect all metal parts for cracks, corrosion, or broken fittings.
- (2) Check all threaded parts for damaged threads.
- (3) Inspect inside of cover plate for wear damage.
- (4) Check impeller for damage or wear.
- (5) Inspect wear plate for damage or wear.
- (6) Inspect pump body for cracks, corrosion, and evidence of leaks.

c. Repair. Repair is limited to replacement of parts found defective during inspection.

d. Installation.**NOTE**

Be careful not to damage rubber gasket of shaft seal during installation.

- (1) Install shaft seal (23).
- (2) Install three studs (22) into pump body (20).
- (3) Apply silicone compound to plug (21) and install plug into pump body (20).
- (4) Install pump body (20) onto engine with new three lock washers (19) and three screws (18).
- (5) Apply silicone compound to shaft seal (23).
- (6) Install wear plate (13) and three screws (12).

CAUTION

Failure to set the clearance between the wear plate and the impeller will cause the pump to function badly or damage the pump. Be sure that the clearance between the wear plate and the impeller is between 0.010 and 0.015 inches (0.254 to 0.381 mm).

(7) Determine the shim thickness required to obtain a clearance of 0.010 to 0.015 inch (0.254 to 0.381 mm) between impeller and wear plate by the following procedure:

- (a) Install O-ring (16), key (15), adapter shaft (14), and screw (8) onto engine shaft.

CAUTION

Improper measurement of clearance will damage pump or reduce pump capacity. To insure proper measurement, be sure that all shims are pressed against adapter shaft during measurement.

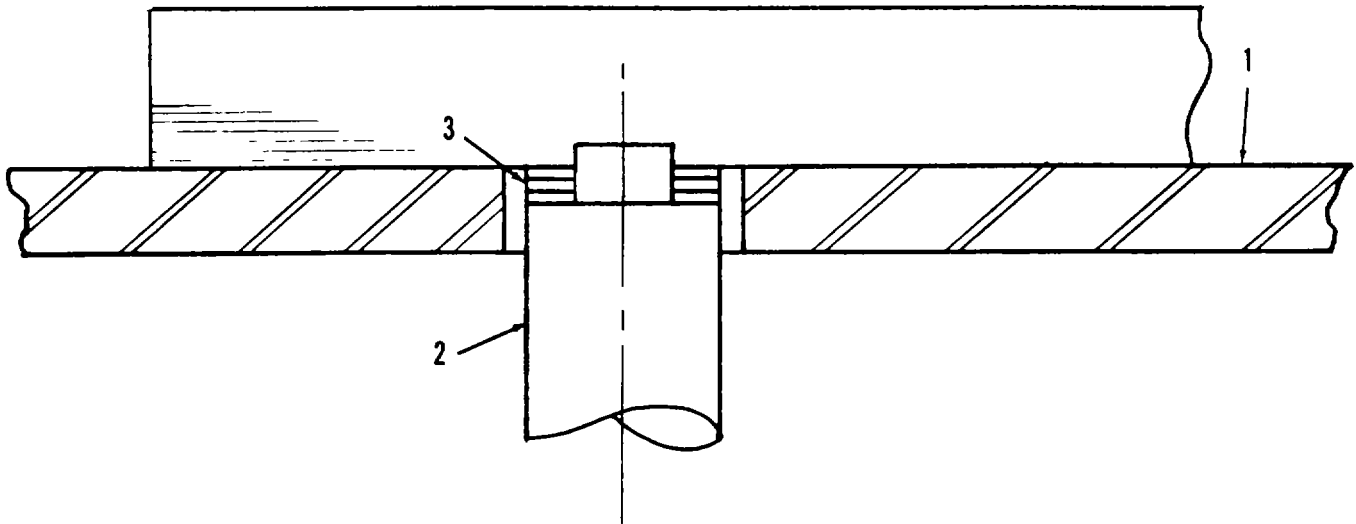

Figure 4-18. Measuring Impeller Clearance.

(b) (Refer to Figure 4-18.) Position a straight edge across the surface of the wear plate (13) and install single .010 shims onto shoulder of adapter shaft until the straight edge comes into contact with the edge of a shim when the straight edge is slid across the wear plate surface and against the adapter shaft.

(c) Remove one .010 shim and replace with one .005 shim and repeat Step (b). If straight edge does not touch the edge of the .005 shim, remove the .005 shim and install two .010 shims. This will provide a clearance of about .015 in. If the straight edge does touch the edge of the .005 shim, remove .005 shim and replace it with one .010 shim. This will provide about .010 clearance.

(d) When clearance is correct, remove screw (1), washer (10), and lock washer (9). Then install impeller (11), washer (10), new lock washer (9), and screw (8).

- (8) Install peeler (7) into pump.
- (9) Install plastic washer (6), set screw (5), and nut (4).
- (10) Adjust the peeler by performing the following steps.

4-26. **PUMP ASSEMBLY REPAIR AND REPLACEMENT.** - Continued.

d. **Installation.** - Continued.

CAUTION

Improper adjustment of peeler will cause damage to pump or reduce pump capacity. Be sure feeler gauge is placed between peeler and one of the blades of the impeller.

(a) Loosen nut (4) and set screw (5) and use a feeler gauge to adjust gap between peeler (7) and impeller until gap is 0.015 in. (0.381 mm).

(b) Tighten set screw (5) and then tighten nut (4).

(11) Apply silicone compound to packing (3).

(12) Install new packing (3), cover plate (2), and two shoulder bolts (1) onto pump.

4-27. FUEL TANK ASSEMBLY REPAIR AND REPLACEMENT.

This Task Covers:

- a. Removal b. Cleaning c. Inspection d. Repair e. Installation
-

Initial Setup:

Tools Required

Tool Kit, General Mechanic's (Appendix B, Item 1)
Pan, Drain (Appendix B, Item 2)

Materials Required

Cloth, Lint-Free (Appendix E, Item 1)

Equipment Condition

DED pump assembly shut down and cool.
Outlet enclosure removed (see paragraph 4-23).

WARNING

Improper care in handling fuel can cause fire and explosion which can cause severe injury or death to operating personnel. To avoid fire or explosion during engine refueling:

- DO NOT allow any flame producing material within 50 feet (15.25 m) of fuel during equipment filling.
 - DO NOT smoke while refueling.
 - DO NOT let fuel drip onto any hot surface.
 - DO NOT overfill fuel tank.
 - DO NOT refuel unit while engine is running.
-

a. Removal (Refer to Figure 4-19).

(1) Remove fuel cap (1) and drain plug (2) located at the bottom right corner of the fuel tank (3) and drain out all fuel into a clean container. Dispose of fuel per FM 10-69.

(2) Release hose clamps (4) on overflow hose (5).

(3) Release hose clamp (6) on fuel line (7) at injection pump (8) and disconnect hose from fuel tank (3).

(4) Remove hex head screw (9), lifting bolt (10), and washer (11) securing the upper part of the fuel tank stay bracket (12) and remove stay bracket and two dampers (13).

(5) Remove fuel tank (3).

(6) Remove two clamps (14) and pipe fuel gauge (15).

(7) Remove two bolts (16), stay (17), and two dampers (18).

b. Cleaning.

(1) Wipe outside of fuel tank with clean, dry, lint-free cloth to remove any oil or grease deposits.

(2) When tank is completely clean of any residual fuel, remove cap and clean away any deposits.

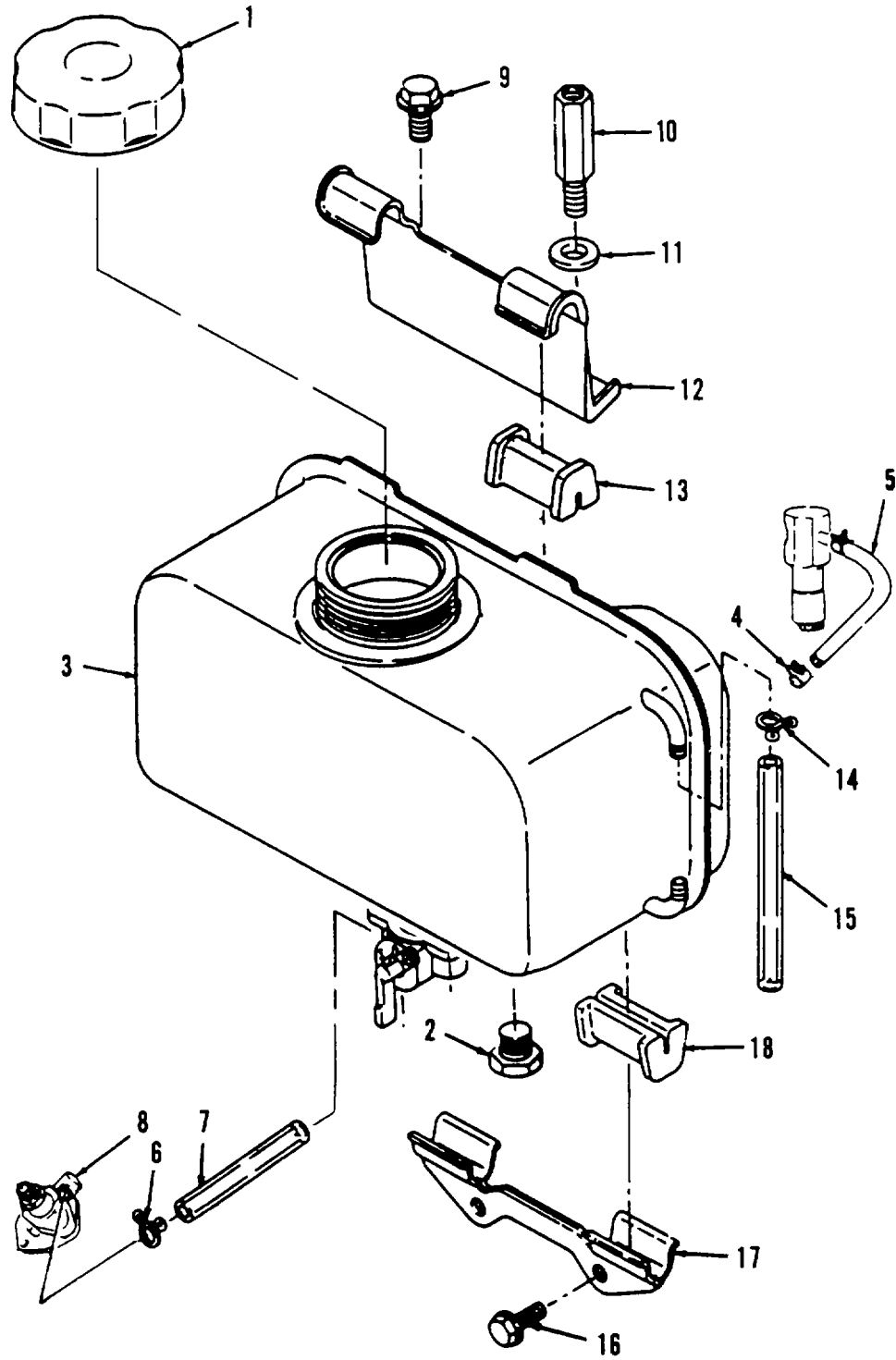

Figure 4-19. Fuel Tank Assembly Repair and Replacement.

4-27. FUEL TANK ASSEMBLY REPAIR AND REPLACEMENT. - Continued.**c. Repair.**

Repair is limited to replacement of defective parts.

d. Installation.

(1) Install two dampers (18), stay (17), and two bolts (16).

(2) Install pipe fuel gauge (15) and two clamps (14).

(3) Attach fuel tank (3) using two dampers (13), upper stay bracket (12), washer (11), lifting bolt (10), and hex head screw (9).

(4) Connect fuel line hose (7) and hose clamp (6) to fuel tank (3) and then connect other end of hose to injection pump (8).

(5) Connect overflow hose (5) and clamp (4) to fuel tank (3).

(6) Replace drain plug (2) and fuel cap (1).

(7) Check carefully for any leaks when filling the fuel tank.

4-28. FUEL FILTER, INLET REPLACEMENT.**This Task Covers:**

- a. Removal b. Installation

Initial Setup:**WARNING****Tools Required**

Tool Kit, General Mechanic's (Appendix B, Item 1)

Material's Required

None

Equipment Condition

DED pump assembly shut down and cool.

Improper care in handling fuel can cause fire and explosion which can cause severe injury or death to operating personnel. To avoid fire or explosion during engine refueling:

- DO NOT allow any flame producing material within 50 feet (15.25 m) of fuel during equipment filling.
- DO NOT smoke while refueling.
- DO NOT let fuel drip onto any hot surface.
- DO NOT overfill fuel tank.
- DO NOT refuel unit while engine is running.

a. Removal (Refer to Figure 4-20).

- (1) Remove fuel tank cap (1) from fuel tank (2).
- (2) Remove inlet fuel filter (3).

b. Installation.

- (1) Install fuel inlet filter (3) into fuel tank (2).
- (2) Install fuel tank cap (1) onto fuel tank (2).

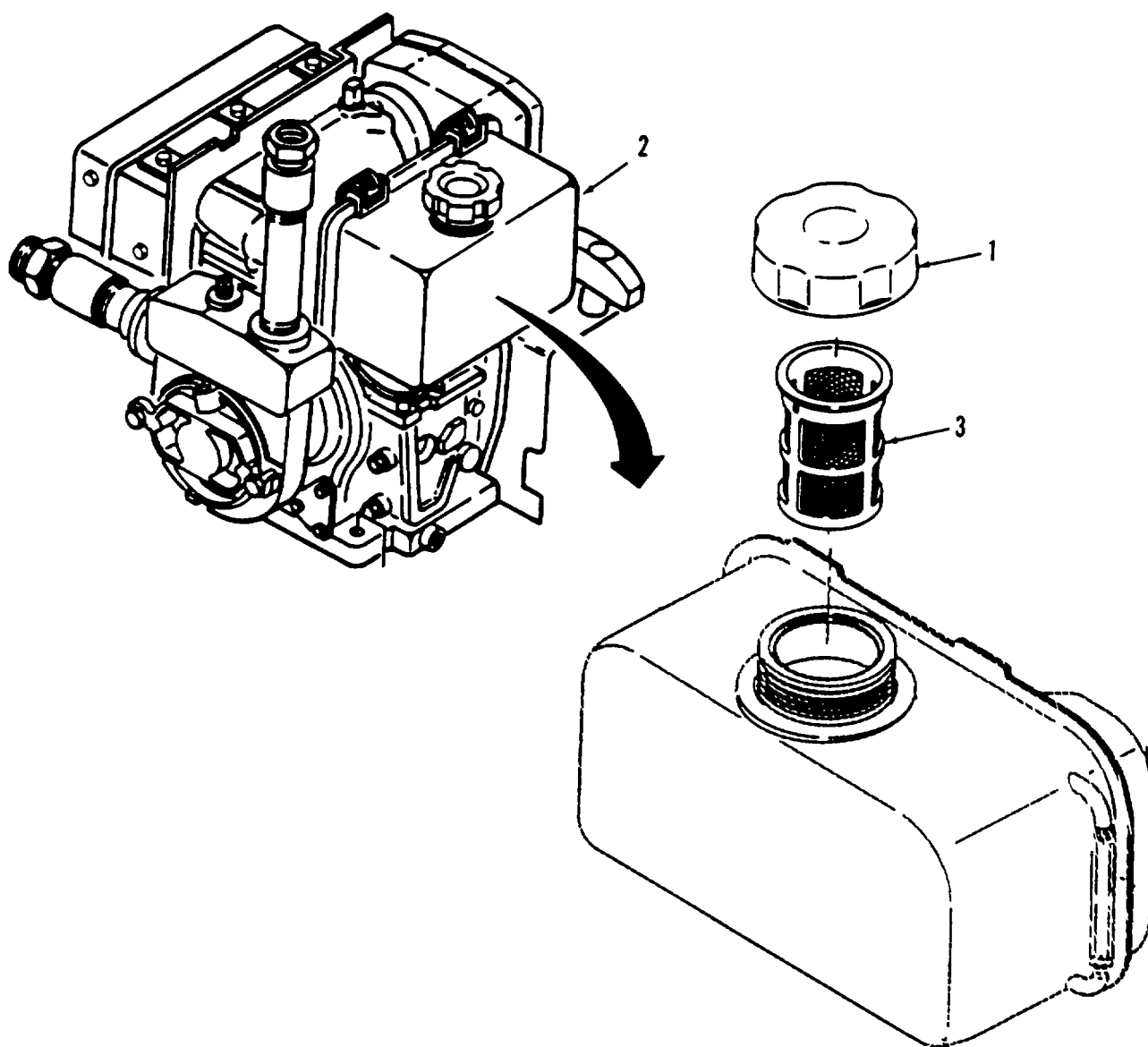

Figure 4-20. Fuel Filter, Inlet Replacement.

4-29. FUEL COCK AND FUEL FILTER, OUTLET REPLACEMENT.**This Task Covers:**

- a. Removal b. Service c. Installation

Initial Setup:**Tools Required**

Tool Kit, General Mechanic's (Appendix B, Item 1)
Pan, Drain (Appendix B, Item 2)

Material's Required

Diesel Fuel (Appendix E, Item 6)
O-ring, (Refer to TM10-4320-316-24P)

Equipment Condition

DED pump assembly shut down and cool.

WARNING

Improper care in handling fuel can cause fire and explosion which can cause severe injury or death to operating personnel. To avoid fire or explosion during engine refueling:

- DO NOT allow any flame producing material within 50 feet (15.25 m) of fuel during equipment filling.
- DO NOT smoke while refueling.
- DO NOT let fuel drip onto any hot surface.
- DO NOT overfill fuel tank.
- DO NOT refuel unit while engine is running.

a. Removal (Refer to Figure 4-21).

- (1) Remove fuel tank cap (1) and strainer (2).
- (2) Drain all fuel from fuel tank (3) by removing drain plug (4) at bottom of the tank. Dispose of fuel per FM 10-69.
- (3) Loosen clamp (5) and remove fuel line hose (6) from fuel cock (7).
- (4) Remove nut (8), nut (9), and washer (10) securing the fuel cock to studs on the tank, and remove fuel cock (7).
- (5) Remove O-ring (11) from fuel cock (7). Discard O-ring.
- (6) Remove fuel filter (12) and gasket (13) from inside of fuel tank (3).

b. Service.

- (1) Wash the fuel cock (7) and filter (12) thoroughly with diesel fuel.
- (2) Check the filter (12) for cracks or damage. Replace damaged filter.
- (3) Dry fuel cock (7) thoroughly before reinstalling.

c. Installation.

(1) Insert fuel filter (12) and new gasket (13) into fuel tank (3) through fuel tank cap (1) opening and position the fuel filter studs through the holes in the bottom of the fuel tank.

(2) Position fuel cock (7) with a new O-ring (11) over the two studs. Be sure that the shut off handle on the fuel cock points away from the engine.

(3) Install washer (10), nut (9), and nut (8) onto fuel cock (7).

(4) Replace fuel line hose (6) and clamp (5) onto fuel cock (7).

(5) Install drain plug (4).

(6) Replace strainer (2) and fuel tank cap (1) onto fuel tank (3).

(7) Check for leaks after refilling. Tighten any loose fasteners or clamps causing leaks.

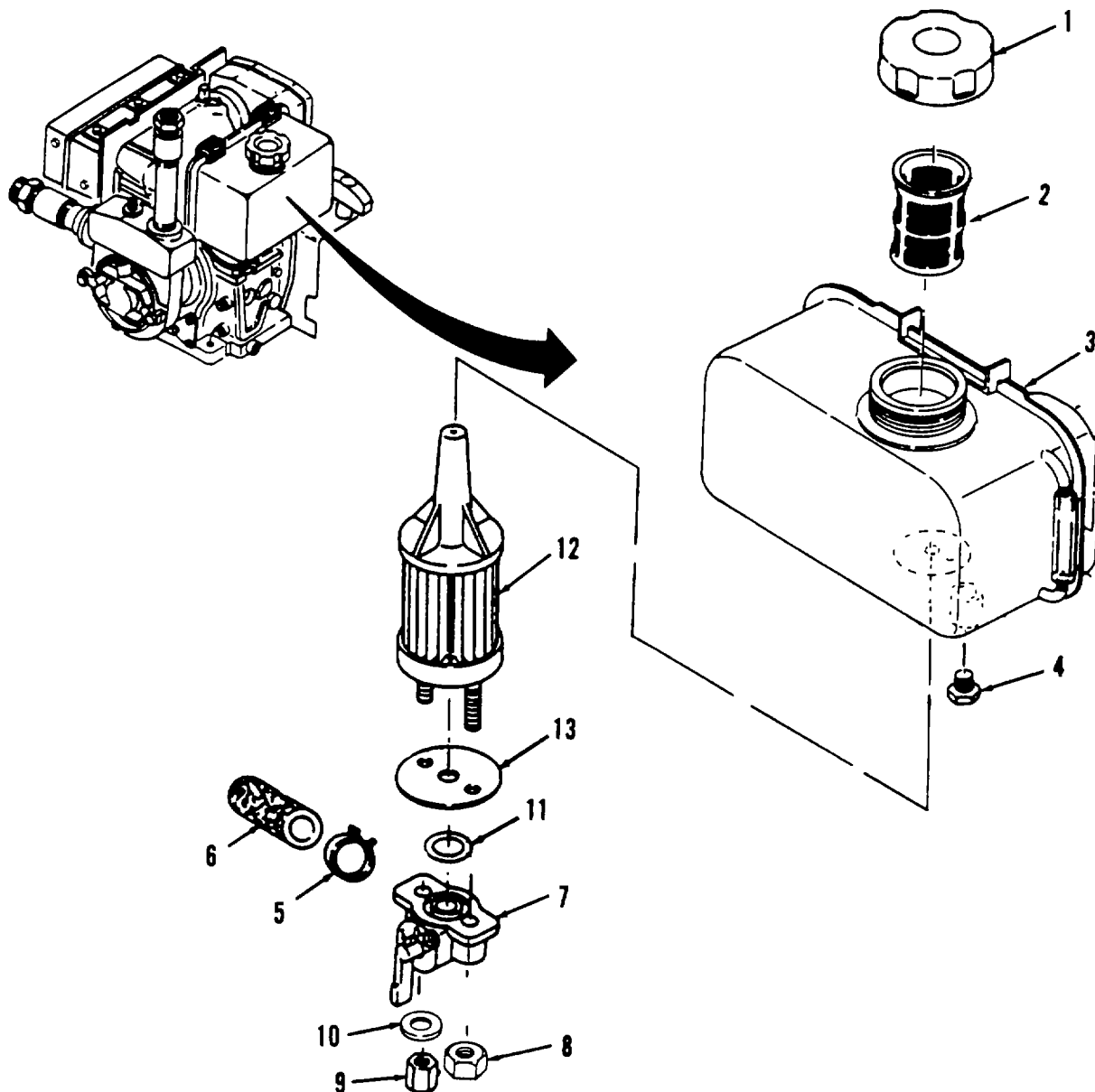

Figure 4-21. Fuel Cock and Fuel Filter, Outlet Replacement.

4-30. FUEL LINES REPLACEMENT.**This Task Covers:**

- a. Removal b. Service c. Installation

Initial Setup:**Tools Required**

Tool Kit, General Mechanic's (Appendix B, Item 1)
Pan, Drain (Appendix B, Item 2)

Material's Required

Cloth, Lint Free (Appendix E, Item 1)
Diesel Fuel (Appendix E, Item 6)

Equipment Condition

DED pump assembly shut down and cool.
Inlet enclosure removed (see paragraph 4-22).
Outlet enclosure removed (see paragraph 4-23)

WARNING

Improper care in handling fuel can cause fire and explosion which can cause severe injury or death to operating personnel. To avoid fire or explosion during engine refueling:

- DO NOT allow any flame producing material within 50 feet (15.25 m) of fuel during equipment filling.
- DO NOT smoke while refueling.
- DO NOT let fuel drip onto any hot surface
- DO NOT overfill fuel tank.
- DO NOT refuel unit while engine is running.

a. Removal (Refer to Figure 4-22).

- (1) Drain all fuel from fuel tank (1) by removing drain plug (2) at bottom of the tank. Dispose of fuel per FM 10-69.
- (2) Turn fuel cock (5) to OFF position.
- (3) Loosen connectors (6) at each end of fuel injection pipe (7).
- (4) Remove fuel injection pipe (7).
- (5) Remove two clamps (8), hose (9), two hose bands (10), and hose (11).
- (6) Wipe up any fuel that has leaked during removal

b. Cleaning.

Thoroughly wash the fuel injection pipe (6) in diesel fuel. Insure that line is clear. Wipe with clean, lint-free cloth.

c. Installation.

- (1) Install hose (11), two hose bands (10), hose (9), and two clamps (8).
- (2) Position fuel injection pipe (7) between fuel injection nozzle and fuel injection pump. Position the pipe so that the fittings line up.
- (3) Carefully hand tighten connectors (6) on fuel injection pipe (7). Finish tightening the two connectors with a wrench taking care not to strip the fittings.

- (4) Install drain plug (2) into bottom of tank (1).
- (5) Fill fuel tank (1) (see paragraph 2-7).
- (6) Turn fuel cock (5) to OPEN position.
- (7) Bleed air from fuel system.

NOTE

Air can enter the fuel pipe system when the engine is first installed, the fuel pipe removed, etc. No air bleeding will be required when the fuel tank runs out of fuel. Bleed the air according to the following instructions:

- (a) Place the throttle control handle in the run position.
- (b) Set the decompression lever to the non-compression position.
- (c) Make sure fuel comes out of the fuel injection nozzle while the recoil starter is pulled. The injection sound can be heard.

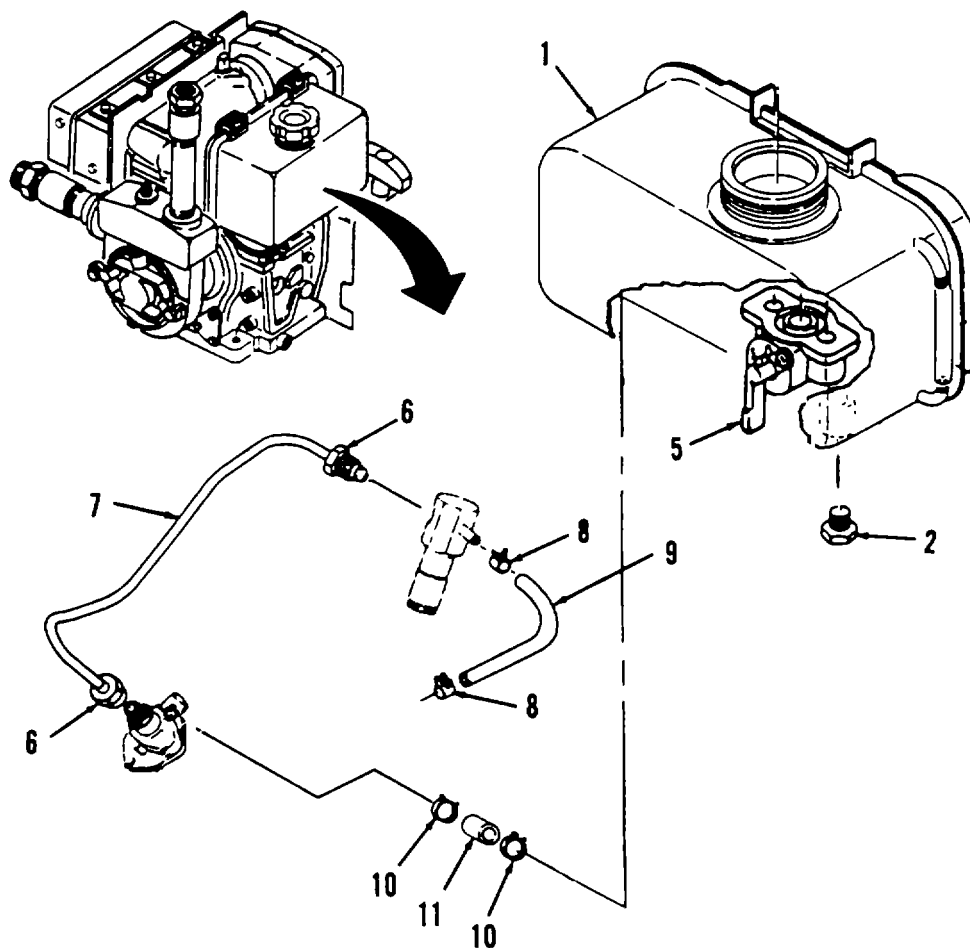

Figure 4-22. Fuel Lines Replacement.

4-31. AIR CLEANER, FILTER ELEMENT, AND AIR INTAKE PIPE REPAIR AND REPLACEMENT.

This Task Covers:

- a. Removal b. Inspection c. Repair. d. Installation
-

Initial Setup:**Tools Required**

Tool Kit, General Mechanic's (Appendix B, Item 1)

Material's Required

Gasket, (Refer to TM10-4320-316-24P)

Gasket, (Refer to TM10-4320-316-24P)

Equipment Condition

DED pump assembly shut down and cool.

Cooling fan housing removed (see paragraph 4-33).

a. Removal (Refer to Figure 4-23).

- (1) Loosen and remove wing nut (1) and washer (2).
- (2) Remove air cleaner housing cover (3).
- (3) Remove air cleaner element (4).
- (4) Remove three hex nuts (5) securing the air cleaner housing (6).
- (5) Remove air cleaner housing (6). Discard gasket (7).
- (6) Remove hex bolt (8) and air intake pipe (9) and air intake gasket (10). Discard gasket (10).

b. Inspection.

- (1) Check that air cleaner housing (6) and cover (3) are free from dirt.
- (2) Check air cleaner housing (6) and cover (3) for damage. Replace if necessary.

c. Repair.

Repair is limited to replacement of defective parts.

d. Installation.**CAUTION**

Never run the engine without the air cleaner element. Rapid engine wear may result.

- (1) Place new gasket (10) in place, position air intake bend (9), and secure with hex bolt (8).
- (2) Place new gasket (7) on intake manifold studs.

- (3) Place air cleaner housing (6) over studs and secure with three hex nuts (5).
- (4) Install air cleaner element (4) into air cleaner housing (6).
- (5) Replace air cleaner housing cover (3).
- (6) Replace and tighten washer (2) and wing nut (1).

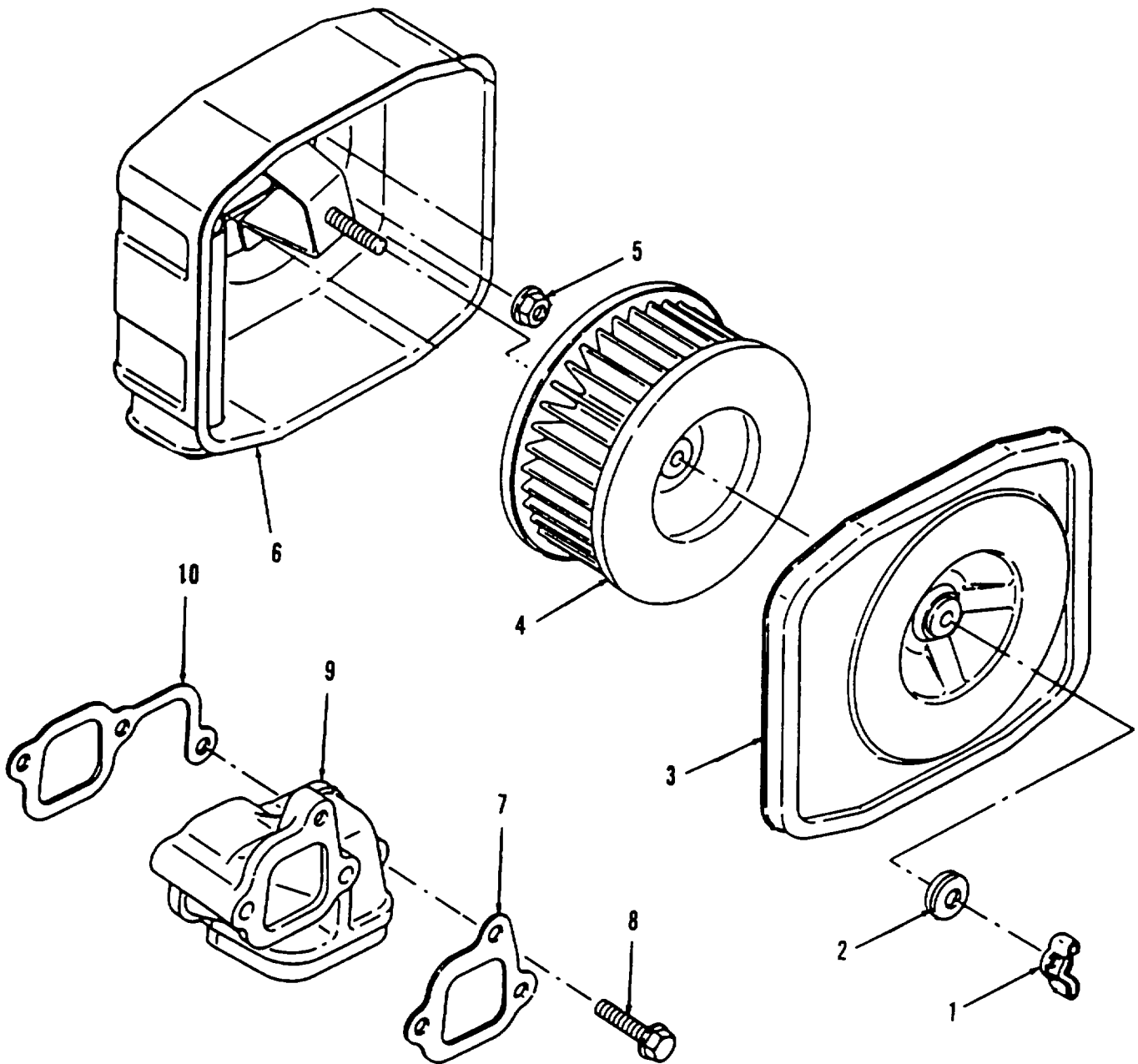

Figure 4-23. Air Cleaner, Filter Element, and Air Intake Pipe Repair and Replacement.

4-32. EXHAUST SILENCER REPAIR AND REPLACEMENT.

This Task Covers:

- a. Removal b. Inspection c. Repair. d. Installation
-

Initial Setup:**Tools Required**

Tool Kit, General Mechanic's (Appendix B, Item 1)

Material's Required

Gasket, (Refer to TM10-4320-316-24P)

Equipment Condition

DED pump assembly shut down and cool.

Muffler baffle assembly removed (see paragraph 4-21).

a. Removal (Refer to Figure 4-24).

- (1) Remove two hex head nuts (1) securing the exhaust silencer (2) to studs on the exhaust port of the engine.
- (2) Remove two hex head screws (3) securing the bracket on exhaust silencer (2) to the rear of the engine.
- (3) Lift exhaust silencer (2) and gasket (4) from the studs. Discard gasket.

b. Inspection.

Carefully inspect exhaust silencer (2) for cracks, rust, or pin holes.

c. Repair.

Repair is limited to replacement of defective parts.

d. Installation.

(1) Position exhaust silencer (2) and new gasket (4) onto the studs and line up holds in bracket with rear mounting holes on engine.

(2) Secure exhaust silencer (2) with two hex head nuts (1) onto the studs and two hex head screws

(3) in the mounting holes on engine.

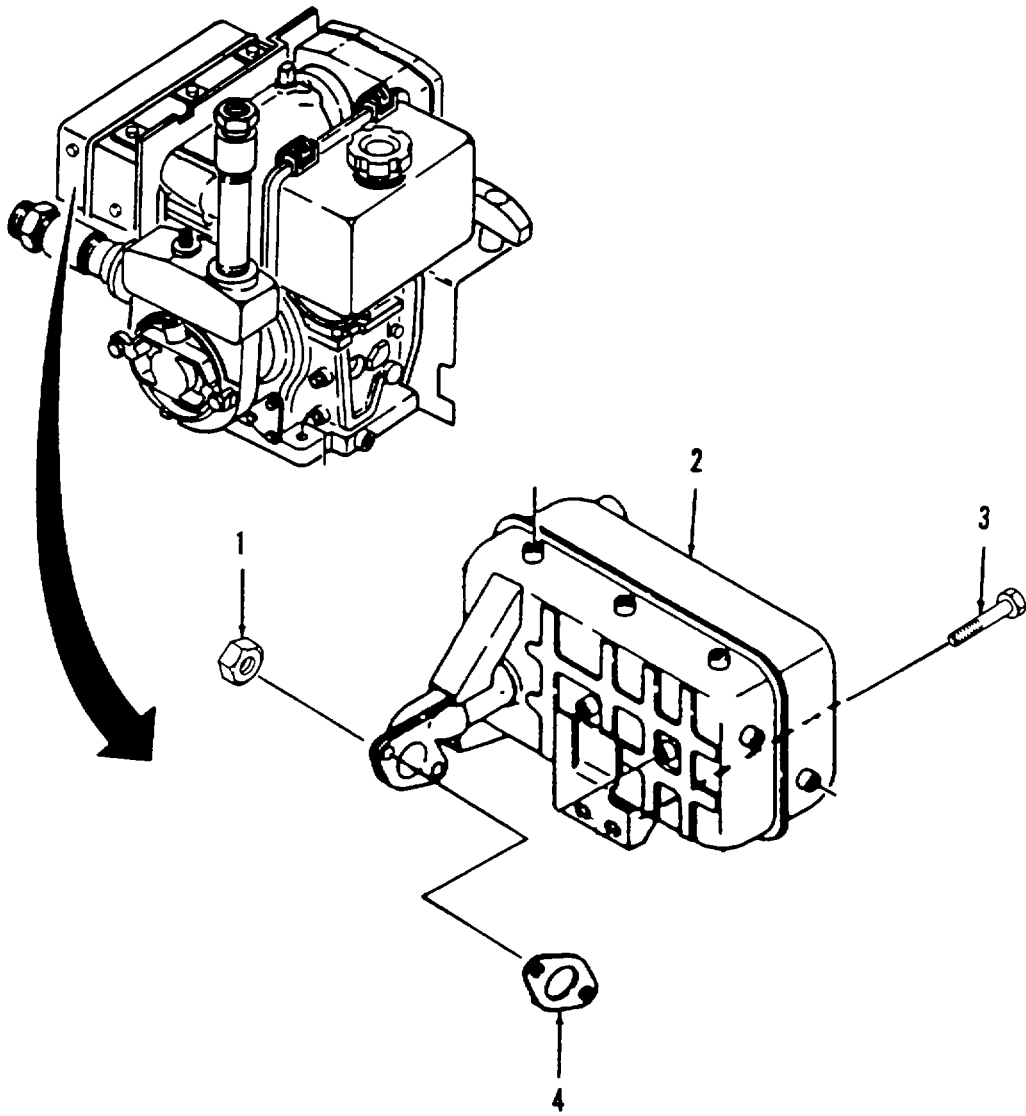

Figure 4-24. Exhaust Silencer Repair and Replacement.

4-33. RECOIL STARTER AND COOLING FAN CASE REPAIR AND REPLACEMENT.

This Task Covers:

- a. Removal b. Inspection c. Repair. d. Installation
-

Initial Setup:**Tools Required**

Tool Kit, General Mechanic's (Appendix B, Item 1)

Material's Required

Seal, (Refer to TM10-4320-316-24P)

Equipment Condition

DED pump assembly shut down and cool.

NOTE

If you are only replacing the recoil starter, only perform removal steps (1) and (2) of the baffle removal procedure.

Baffles removed (see paragraph 4-21).

a. Removal (Refer to Figure 4-25).

- (1) Remove four bolts (1).
- (2) Remove the recoil starter assembly (2) as a self-contained unit.
- (3) Remove four bolts (3), four washers (4), four collars (5), and four rubber cushions (6).
- (4) Remove cooling fan case (7) and seal (8). Discard seal.
- (5) Remove screw (8) and cover (9).

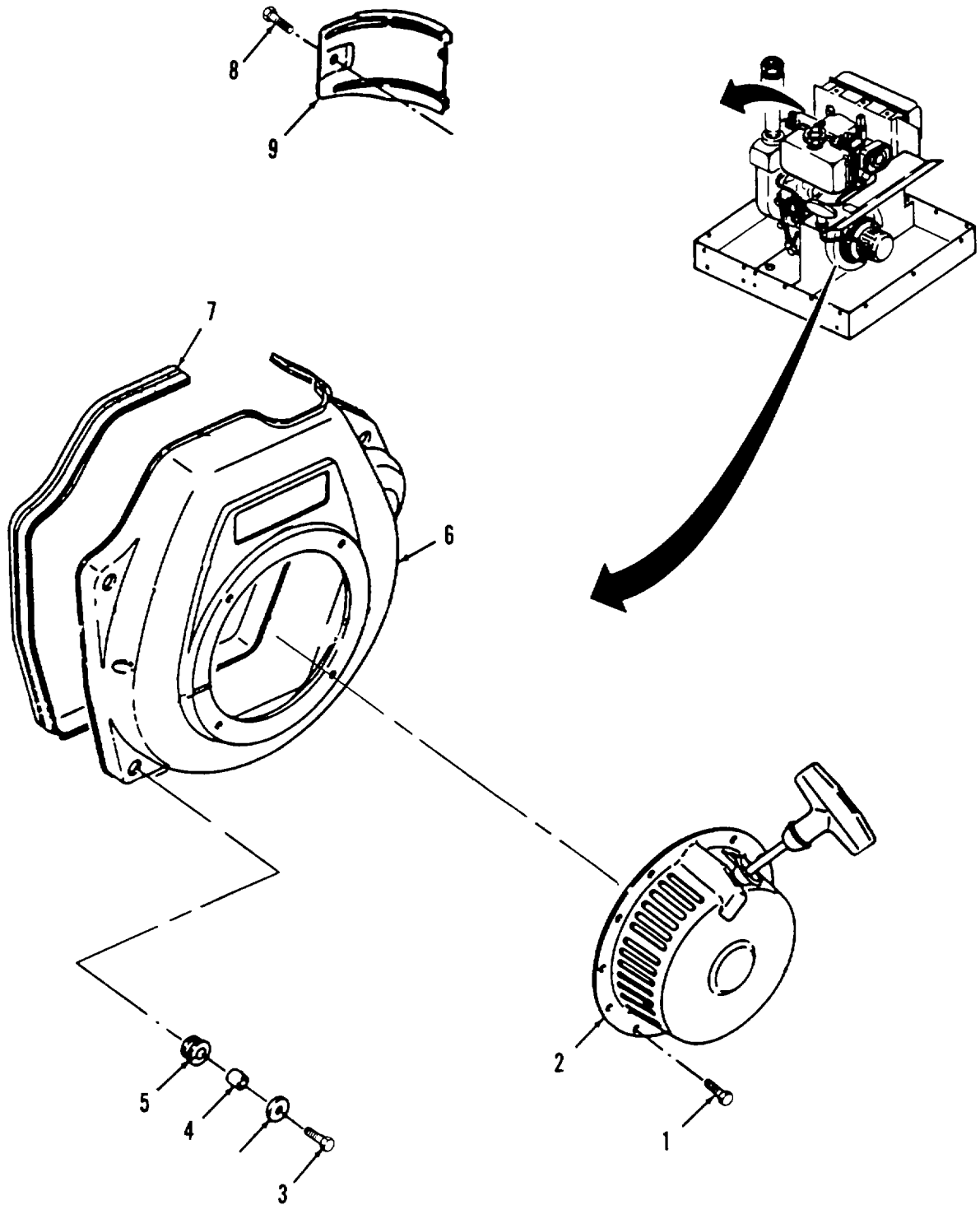

Figure 4-25. Recoil Starter and Fan Cooling Case Repair and Replacement.

4-33. RECOIL STARTER AND COOLING FAN CASE REPAIR AND REPLACEMENT. - Continued.**b Inspection.**

- (1) Pull the rope. It should pull easily with no binding.
- (2) Observe the drive mechanism. The cam that engages the flywheel cap should extend freely.
- (3) Allow the rope to retract. The engaging mechanism should retract.

c. Repair.

Repair of recoil starter is limited to replacement of defective parts.

d. Installation.

- (1) Install cover (9) and screw (8).
- (2) Place seal (7) and cooling fan case (6) into position on engine.
- (3) Install four rubber cushions (5), four collars (4), and four screws (3).
- (4) Check the recoil starter (2) for operation before installing it on the engine.
- (5) Position the recoil starter (2) on the cooling fan case (6) as noted at removal. Push the cam back into the assembly if it is extended.
- (6) Install four bolts (1) and baffle (see paragraph 4-21).
- (7) Check recoil starter (3) for operation on the engine.

4-34. FUEL INJECTOR PUMP REPLACEMENT.

This Task Covers:

- a. Removal b. Inspection c. Installation
-

Initial Setup:**Tools Required**

Tool Kit, General Mechanic's (Appendix B, item 1)

Material's Required

None

Equipment Condition

DED pump assembly shut down and cool.
 Fuel tank removed (see paragraph 4-27).
 Inlet enclosure removed (see paragraph 4-22).

a. Removal. (Refer to Figure 4-26).

- (1) Loosen hex nut (2) securing pump viewing access plate (3) and gasket (4). Discard gasket.
- (2) Loosen two hex nuts (5) securing fuel injection pump (6), and remove pump together with base mounting plate.
- (3) Remove metal shim (7).
- (4) If flat tappet (8) is not removed with fuel injection pump, then remove flat tappet with fingers.

b. Inspection. Check for damaged parts and/or evidence of leakage.**c. Installation.****NOTE**

When replacing or installing a new fuel injection pump, it is usually not necessary to test or adjust the injection timing. Run the engine and observe performance and exhaust color (refer to Table 4-2) before adjusting timing.

- (1) Insert bottom flat tappet (8) down into engine block, closed end first.
- (2) Adjust speed control lever (9) until governor yoke (10) is centered in engine block opening.
- (3) Refer to Figure 4-27. The access hole on fuel injection pump has an access hole pointer match mark (1). Make sure the pointer (2) of the control lever lines up with the match mark.
- (4) Refer to Figure 4-26. Position metal shim (7) and carefully insert fuel injection pump (6) onto the studs, making sure the speed control lever engages into governor yoke (9).
- (5) Secure fuel injection pump onto studs using two nuts (5).
- (6) Attach pump viewing access plate (3) and new gasket (4) with one hex nut (2).

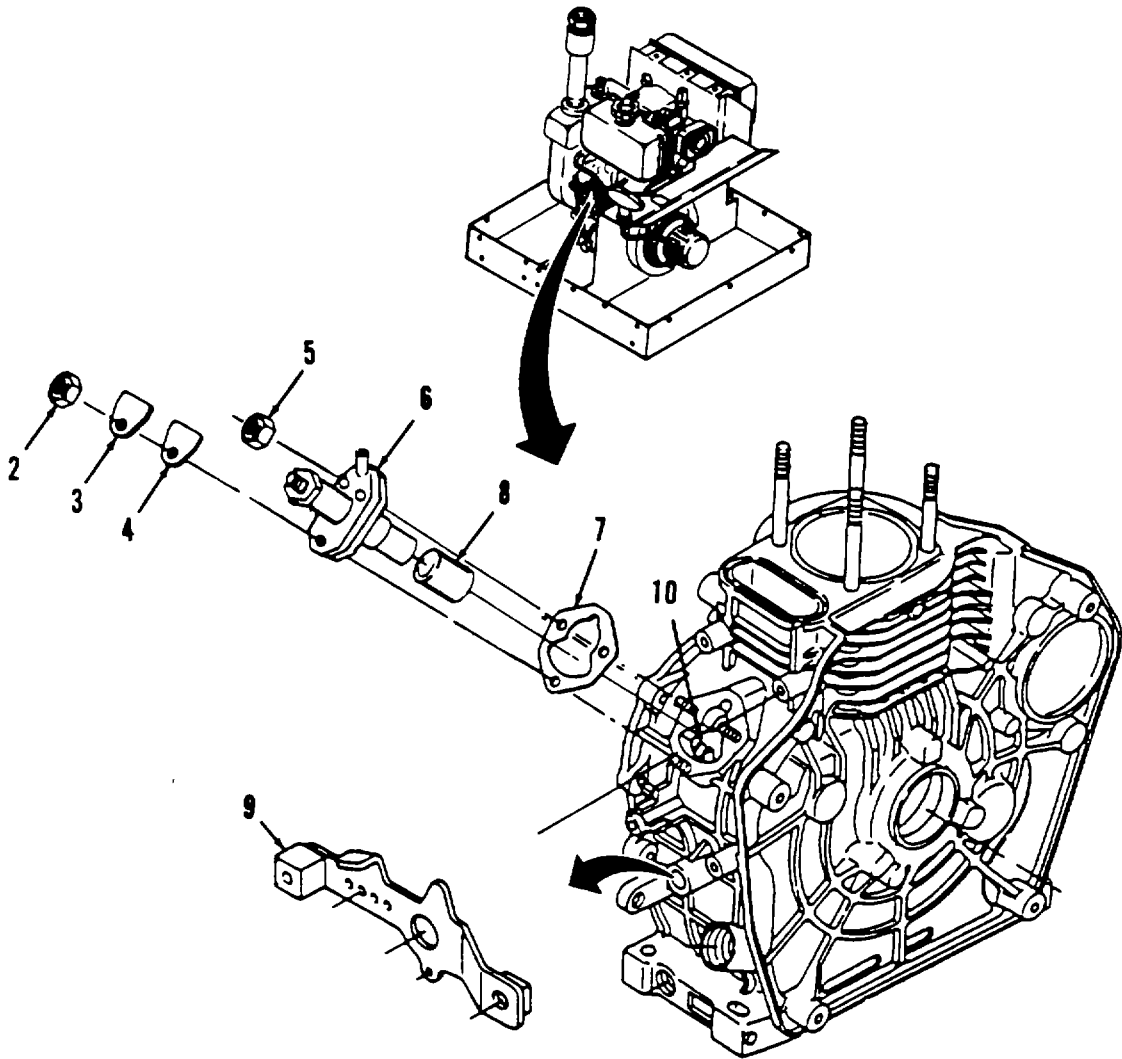

Figure 4-26. Fuel Injector Pump Replacement.

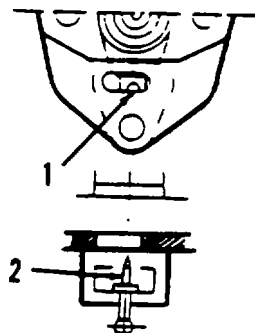

Figure 4-27. Fuel Injector Pump Alignment.

4-35. LUBE OIL STRAINER REPAIR AND REPLACEMENT.

This Task Covers:

- a. Removal b. Repair c. Installation
-

Initial Setup:**Tools Required**

Tool Kit, General Mechanic's (Appendix B, Item 1)

Materials Required

Diesel Fuel (Appendix E, Item 6)

O-ring, (Refer to TM10-4320-316-24P)

Equipment Condition

DED pump assembly shut down and cool.

Outlet enclosure removed (see paragraph 4-23).

a. Removal. (Refer to Figure 4-28).

- (1) Drain oil from engine (Refer to LO10-4320-316-12).
- (2) Remove hex head bolt (1) from crankcase (2).
- (3) Remove lube oil strainer (3) and O-ring (4). Discard O-ring.

b. Repair.

Repair is limited to replacement of defective parts.

c. Installation.

- (1) Lubricate new O-ring (4) with engine oil and insert into groove on lube oil strainer (3).
- (2) Insert lube oil strainer (3) into hole in crankcase (2).
- (3) Install hex head bolt (1) to attach lube oil strainer (3) to crankcase (2).
- (4) Fill engine with 0.75 quart of proper engine oil (Refer to LO10-4320-316-12).

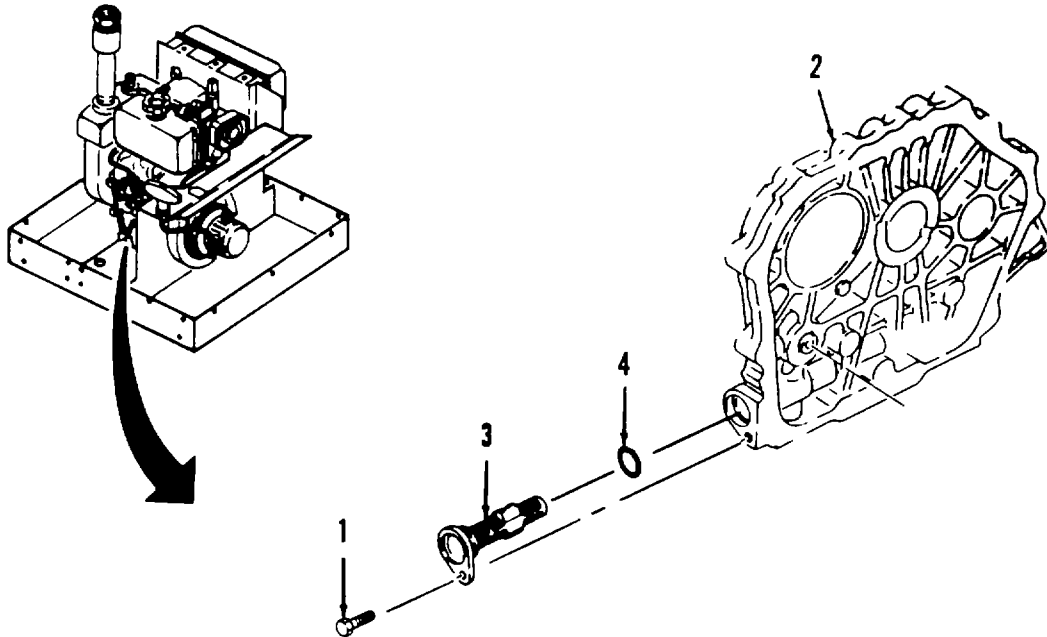

Figure 4-28. Lube Oil Strainer Repair and Replacement.

4-36. OIL CAP/GAUGE REPAIR AND REPLACEMENT.

This Task Covers:

- a. Removal b. Repair c. Installation
-

Initial Setup:**Tools Required**

Tool Kit, General Mechanic's (Appendix B, Item 1)

Material's Required

O-ring, (Refer to TM10-4320-316-24P)

Equipment Condition

DED pump assembly shut down and cool.
Inlet enclosure removed (see paragraph 4-22).

NOTE

Engine is equipped with two oil/cap gauges.

a. Removal. (Refer to Figure 4-29).

- (1) Remove oil cap/gauge (1) from engine crankcase (2).
- (2) Remove O-ring (3) from oil cap/gauge (1). Discard O-ring.
- (3) Remove plug (4) and washer (5).

b. Repair.

Repair is limited to replacement of defective parts.

c. Installation.

- (1) Install washer (5) and plug (4).
- (2) Install new O-ring (3) onto oil cap/gauge (1).
- (3) Install oil cap/gauge (1) into engine crankcase (2).

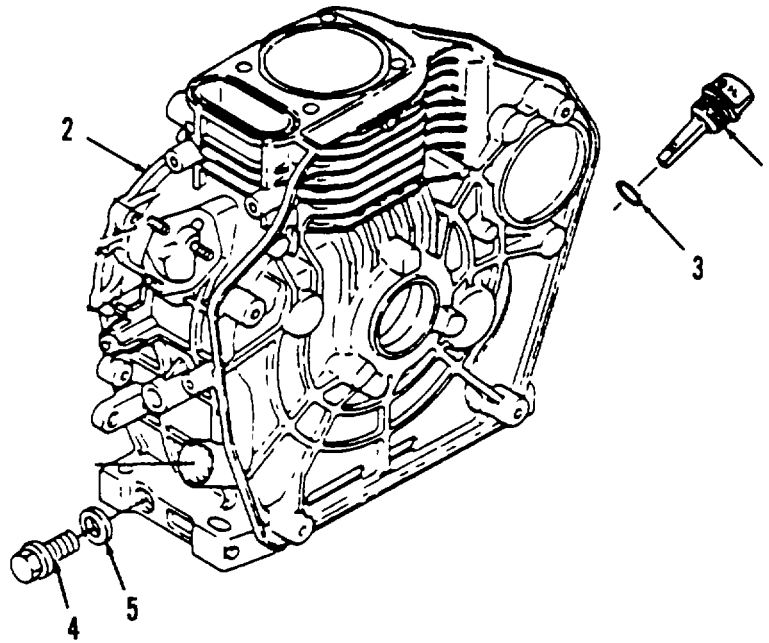

Figure 4-29. Oil Cap/Gauge Repair and Replacement.

SECTION VII. PREPARATION FOR STORAGE OR SHIPMENT

4-37. PREPARATION FOR GENERAL STORAGE OR SHIPMENT. Before storing the DED pump, it must be properly prepared. To insure that the unit will operate properly when it is removed from storage or shipment, the following procedures must be performed.

- a. Operate engine for about 3 minutes and then stop.
- b. Drain the engine lube oil while the engine is still warm.
- c. Remove drain pipe cap and allow pump to drain.
- d. Remove drain plug on fuel tank and allow tank to drain.
- e. Replace fuel tank drain plug and pump drain plug.
- f. Fill engine with new lube oil. Refer to LO10-4320-316-12 for proper lubrication oil to be used.
- g. Remove rubber plug on cylinder head and add about 5 drops of lube oil. Replace rubber plug.
- h. Hold decompression lever down and slowly pull recoil starter rope 2 or 3 times (do not start engine).
- i. Pull decompression lever up.
- j. Pull the recoil starter rope slowly; stop when it feels tight. This closes the intake and exhaust valves and helps to prevent rust from forming.

4-38. ADMINISTRATIVE STORAGE OF EQUIPMENT.

a. General.

(1) Placement of equipment in administrative storage should be for short periods of time when a shortage of maintenance effort exists. Items should be in mission readiness within 24 hours or within the time factors determined by the directing authority. During the storage period appropriate maintenance records will be kept.

(2) Before placing equipment in administrative storage, current maintenance services and Equipment Serviceable Criteria (ESC) evaluations should be completed, shortcomings and deficiencies should be corrected, and all Modification Work Orders (MWO) should be applied.

(3) Storage site selection. Inside storage is preferred for items selected for administrative storage. If inside storage is not available, trucks, vans, conex containers and other containers may be used.

b. Intermediate Storage (46 to 180 days). No special handling is required other than protection from damage and the elements.

c. Long Term or Flyable Storage (Indefinite time).

(1) Place the unit into a plywood crate, preferably the original crate used to ship the unit if it has been preserved.

- (2) Wrap the unit with two layers of heavy plastic sheet or barrier paper.
- (3) Tape and strap the wrapping in place.
- (4) Mark the DED pump in accordance with the standard Army procedures contained in TM 740-90-1, Administrative Storage of Equipment.

**CHAPTER 5
DIRECT SUPPORT MAINTENANCE INSTRUCTIONS**

SECTION I. DIRECT SUPPORT REPAIR PARTS, SPECIAL TOOLS, TEST MEASUREMENT AND DIAGNOSTIC EQUIPMENT (TMDE), AND SUPPORT EQUIPMENT

5-1. COMMON TOOLS AND EQUIPMENT. For authorized common tools and equipment, refer to the Modified Table of Organization and Equipment (MTOE) applicable to your unit.

5-2. SPECIAL TOOLS, TMDE, AND SUPPORT EQUIPMENT. The special tools required to service the centrifugal pump are listed and illustrated in TM 10-4320-316-24P, Repair Pars and Special Tools List (RPSTL), and In the Maintenance Allocation Chart (MAC) located in Appendix B of this manual.

5-3. REPAIR PARTS. Repair parts are listed and illustrated in TM10-4320-316-24P.

SECTION II. DIRECT SUPPORT TROUBLESHOOTING

5-4. SYMPTOM INDEX. To assist the direct support maintenance of the DED pump unit, the following index of the troubleshooting symptoms contained in this chapter are provided for quick reference.

MALFUNCTION	PAGE NO.
ENGINE DOES NOT OPERATE PROPERLY	5-2

5-5. INTRODUCTION. This level of troubleshooting contains checks and corrective maintenance actions which will isolate defects to be corrected by specific maintenance procedures. Table 5-1 is a direct support troubleshooting chart. Symptoms listed in this table are accompanied by suggested tests or inspections which, in turn, suggest corrective action and the appropriate maintenance paragraph reference. Corrective action sometimes suggests additional checks to confirm the troubled area or further localize and isolate trouble to a more specific component. Maintenance procedures include removal, cleaning, inspection, repair, replacement, and installation. These maintenance procedures can be found in Section II of this chapter.

Refer to Table 5-1 to locate problematic symptoms, corrective action steps to isolate a faulty component, and references to provide corrective maintenance. The following paragraphs briefly explain the different headings of Table 5-1.

- a. Malfunction.** This is a sequential listing of problematic symptoms. The malfunction number is used for cross reference purposes and to avoid needless repetition.
- b. Test or Inspection.** This suggests further test or inspection checks to localize the symptom cause to a more specific area. It allows corrective action flexibility depending on the outcome of these checks.
- c. Corrective Action.** This lists the corrective action or actions to be taken and the paragraph reference to locate the step-by-step maintenance procedures to fix the fault.

Table 5-1. Direct Support Troubleshooting.

MALFUNCTION	TEST OR INSPECTION	CORRECTIVE ACTION
<p>1. ENGINE DOES NOT OPERATE PROPERLY.</p>	<p>Step 1. Inspect for malfunctioning speed regulator assembly.</p>	<p>Check speed regulator assembly for defective operation (see para. 5-9). Repair and adjust malfunctioning speed regulator assembly.</p> <p>If speed regulator assembly is operating properly, proceed to step 2.</p>
	<p>Step 2. Check for defective fuel injector valve assembly.</p>	<p>Inspect fuel injector valve for damaged components or clogged nozzle (see para. 5-8). Repair defective or clogged fuel injector valve</p> <p>If fuel injector valve is not damaged or clogged, proceed to step 3.</p>
	<p>Step 3. Check that cylinder head valve assembly components are functioning properly and are not broken.</p>	<p>Refer to para. 5-10 and inspect cylinder head assembly for proper operation. Repair as necessary.</p> <p>If engine still fails to start, replace engine (see para. 5-7).</p>

SECTION III. DIRECT SUPPORT MAINTENANCE PROCEDURES

5-6. DIRECT SUPPORT MAINTENANCE PROCEDURES. Maintenance procedures at direct support maintenance level include as necessary: removal, cleaning and inspection, repair or replacement, and installation. Unless the procedure requires special resources or tools, more than one maintenance person or specific equipment conditions, these are not listed for each maintenance procedure. They are listed only for those procedures that require them.

5-7. MOUNTING PLATE REPAIR AND REPLACEMENT.

This Task Covers:

- a. Removal b. Installation
-

Initial Setup:**Tools Required**

Tool Kit, General Mechanic's (Appendix B, Item 1)

Material's Required

Cloth, Lint-Free (Appendix E, Item 1)
Brush, Medium Bristle (Appendix E, Item 2)
Solvent, Dry Cleaning (Appendix E, Item 3)

Equipment Condition

DED pump assembly shut down and cool.
Inlet enclosure removed (see paragraph 4-22).
Outlet enclosure removed (see paragraph 4-23).

a. Removal. (Refer to Figure 5-1).

- (1) Remove four screws (1), four nuts (2), four flat washers (3), four flat washers (4), and four nuts (5).
- (2) Remove mounting plate (6) from engine (7).

b. Installation.

- (1) Install mounting plate (6) onto engine (7).
- (2) Install four nuts (5), four flat washers (4), four flat washers (3), four nuts (2), and four screws (1).

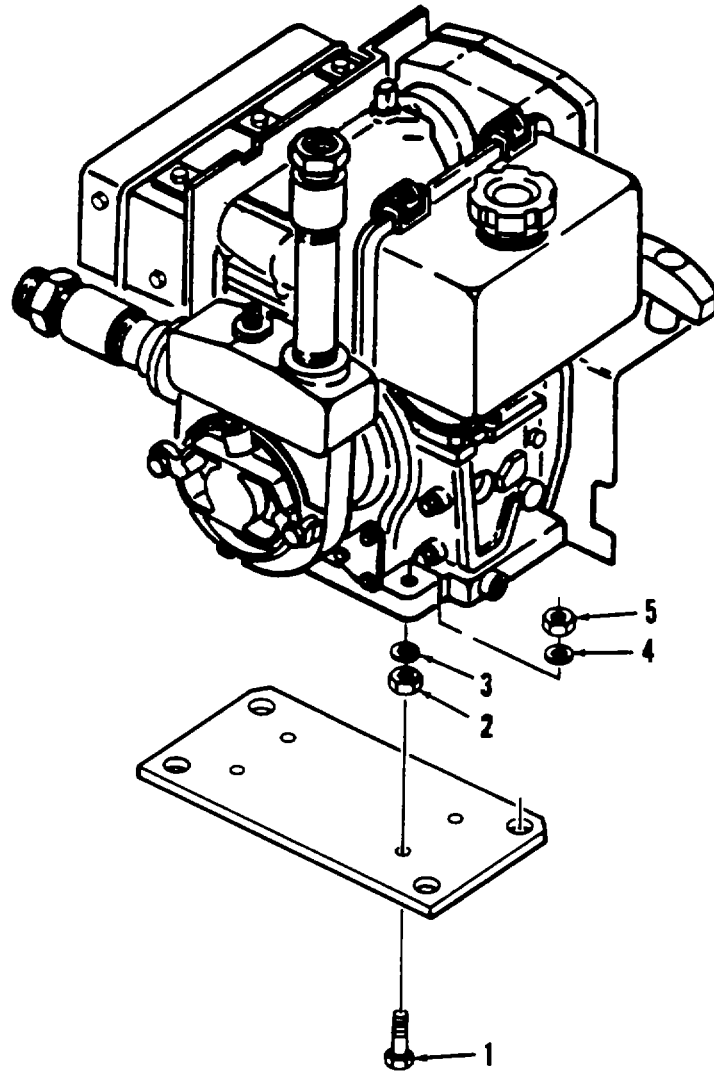

Figure 5-1. Mounting Plate Repair and Replacement

5-8. FUEL INJECTOR VALVE ASSEMBLY REPLACEMENT.

This Task Covers:

- a. Removal b. Test c. Installation
-

Initial Setup:**Tools Required**

Tool Kit, General Mechanic's (Appendix B, item 1)
Test Stand, Injector (Appendix B, Item 3)
Torque Wrench Common 0-175 in-lb (Appendix B, Item 3)

Material's Required

Cloth, Lint-free (Appendix E, Item 1)
Hex Head Bolt, 3/8 x 4 inch UNC (Appendix B, Item 6)

Equipment Condition

DED pump assembly shut down and cool.
Inlet enclosure removed (see paragraph 4-22).

- a. **Removal.** (Refer to Figure 5-2).

CAUTION

Do not touch tip of fuel injection nozzle as damage to equipment can occur.

- (1) Remove clamp (1) and fuel return line (2) from fuel injector valve assembly.
- (2) Remove two hex head nuts (3), retaining plate (4), and the strap for the valve cover rubber plug.

NOTE

If the nozzle is tight, gently pry nozzle using a small pry bar. Be careful not to pry on the fuel return hose hub.

- (3) Carefully remove fuel injection nozzle (5). Wrap it in clean cloth to protect the nozzle tip. Do not place nozzle tip directly on any dirty surface without protection.

- (4) If nozzle gasket (6) and spacer (7) are not attached to nozzle at removal, screw a 3/8 x 4 inch UNC hex head bolt into nozzle gasket, then remove stud bolt. The gasket and spacer should come out and be discarded.

WARNING

Death or serious injury could occur if fuel is not handled properly. Use in a well-ventilated area away from open flame, arcing equipment, ignition sources, heaters, or excessive heat. Always store fuel in properly marked containers. DO NOT SMOKE.

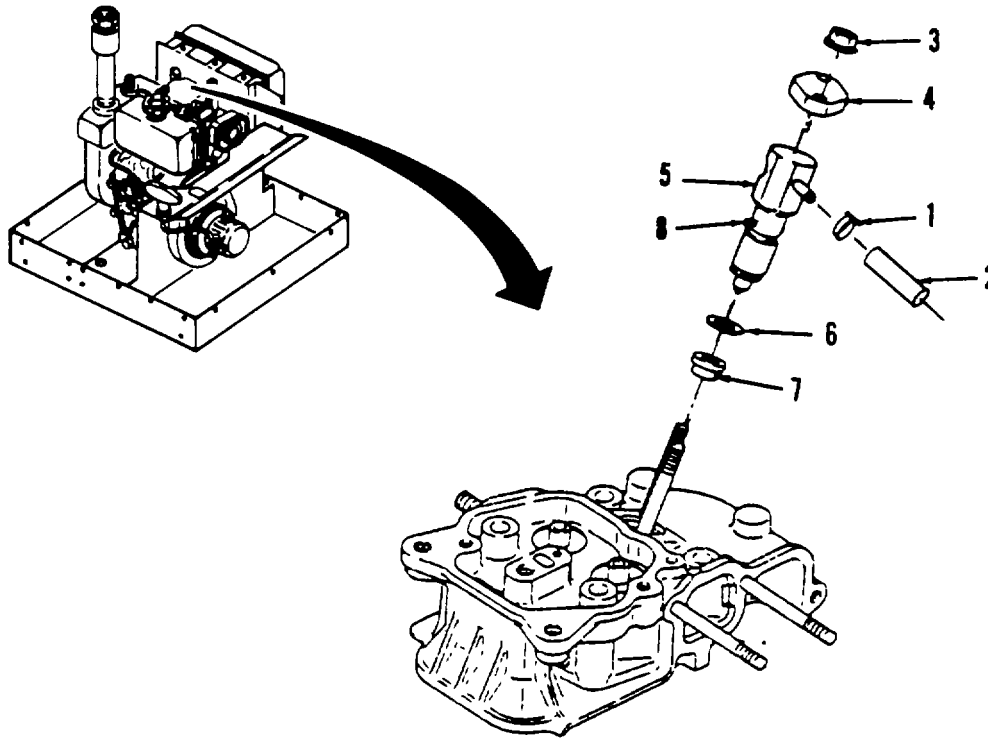

Figure 5-2. Fuel Injector Valve Assembly Replacement.

b. Test.

- (1) Use nozzle test to check injection starting pressure. Pressure should be 2,844 psig (200 kg/cm²) +142 psig (10 kg/sq cm).
- (2) Spray pattern should be equal.
- (3) Pressurize injector nozzle to 2,030 psig (140 kg/sq cm) for 60 seconds and check for leaks.
- (4) If injector nozzle fails either test, replace.

c. Installation.

- (1) Install new fuel injection nozzle gasket (6) and spacer (7) onto fuel injection nozzle (5) before installing nozzle into cylinder block.

NOTE

Make sure nozzle and sleeve surface is clean. Carbon deposits will build up on nozzle in the form of flowers. Flowering lowers combustion performance significantly.

5-8. FUEL INJECTOR VALVE ASSEMBLY REPLACEMENT. - Continued.

(2) Carefully insert the fuel injection nozzle (5) into the cylinder block. Care must be taken in order to avoid damage to nozzle gasket (6).

(3) Make sure fuel injection nozzle (5) positioning pin slides (8) into the positioning slot.

(4) Position the strap for the valve cover rubber plug and secure nozzle (5) to engine with two hex head nuts (3) and retaining plate (4). Torque to 72-94 in-lb (80-100 cm-kg).

(5) Install fuel return line (2) and clamp (1) to injector valve assembly.

5-9. REGULATOR BRACKET ASSEMBLY REPAIR, ADJUSTMENT, AND REPLACEMENT.**This Task Covers:**

- a. Removal b. Inspection c. Repair d. Installation e. Adjustment
-

Initial Setup:**Tools Required**

Tool Kit, General Mechanic's (Appendix B, Item 1)
Tachometer (Appendix B, Item 3)

Material's Required

Diesel Fuel (Appendix E, Item 6)

Equipment Condition

DED pump assembly shut down and cool.
Inlet enclosure removed (see paragraph 4-22).
Control assembly removed (see paragraph 4-15).

a. Removal. (Refer to Figure 5-3).

- (1) Remove mounting bolts (1 and 2).
- (2) Remove regulator bracket (3) with regulator lever (4) and springs attached.
- (3) Remove regulator spring (5) from the governor lever (6) and regulator lever (4).
- (4) Remove return spring (7) from the governor lever (6) and regulator lever (4).
- (5) Remove regulator coil spring (8).
- (6) Remove regulator lever (4) from regulator bracket (3) by unscrewing lever locking knob (9) and locknut (10).
- (7) Remove adjusting bolt (11) and nut (12).
- (8) Remove wire (13), bolt (14), and nut (15).

b. Inspection.

- (1) Clean all parts with diesel fuel.
- (2) Inspect all components for damage or excessive wear. Replace any components damaged or worn.

c. Repair.

Repair is limited to replacement of defective parts.

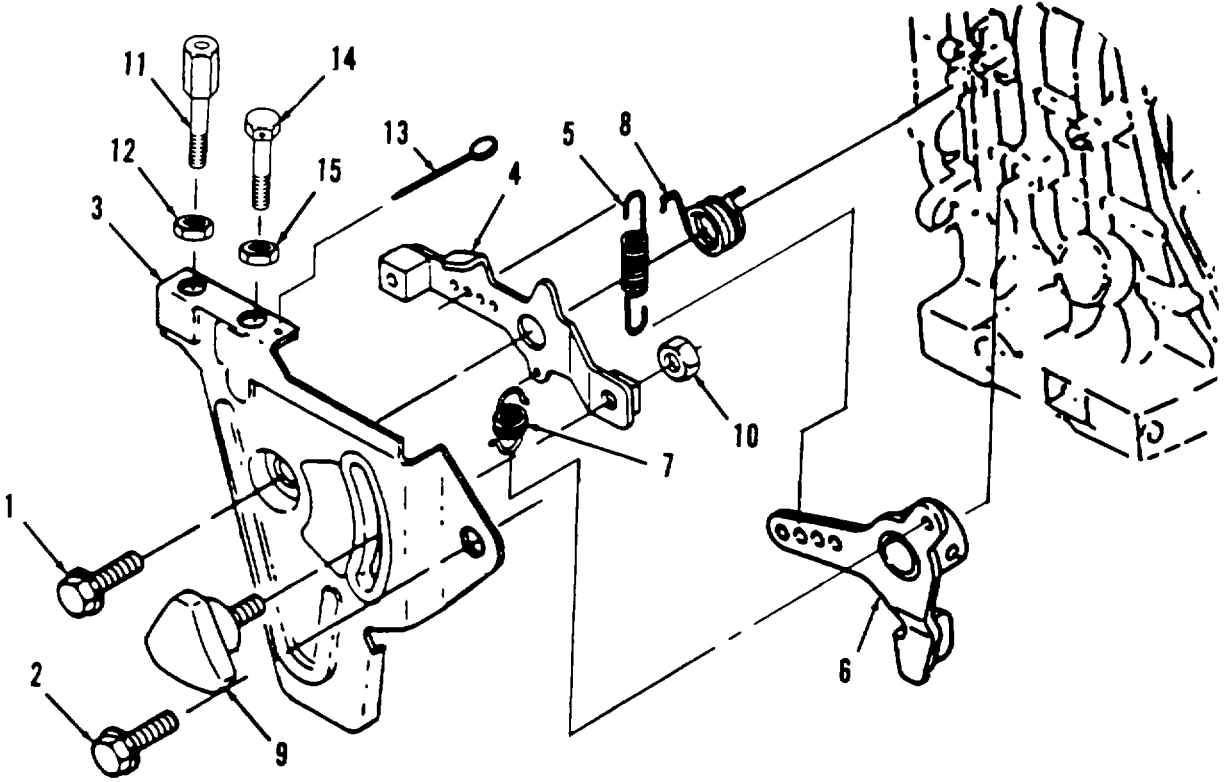

Figure 5-3. Regulator Bracket Assembly Repair and Replacement.

5-9. REGULATOR BRACKET ASSEMBLY REPAIR, ADJUSTMENT, AND REPLACEMENT. - Continued.

d. Installation.

- (1) Install nut (15) and bolt (14).
- (2) Install nut (12) and adjusting bolt (11).
- (3) Install regulator coil spring (8).
- (4) Attach return spring (5) to the governor lever (6) and to regulator lever (4).
- (5) Attach regulator spring (4) to the second hole from the left on the governor lever (2) and connect spring to second hole from the left on regulator lever (3).
- (6) Mount regulator lever (4) to regulator bracket (3) using the locking nut (9). Secure with self-locking nut (10).
- (7) Mount regulator bracket assembly (3) with mounting bolts (2 and 1).
- (8) Lubricate all moving parts with lubricating oil.

e. Adjustment.**CAUTION**

Do not operate engine and pump if all water has been removed from pump.
Pump will be seriously damaged if it is operated without water in the pump body.

- (1) Check that engine RPM is 3,650.
- (2) Loosen nut (15) and adjust bolt (14) until engine operates at 3,650 RPM.
- (3) When engine RPM is correct, tighten nut (15) to hold adjusting bolt (14) into position and install new wire (13) to seal adjustment.

5-10. CYLINDER HEAD ASSEMBLY REPAIR AND REPLACEMENT.

This Task Covers:

- a. Removal b. Inspection c. Repair d. Installation e. Adjustment
-

Initial Setup:**Tools Required**

Tool Kit, General Mechanic's (Appendix B, item 1)
Fitting Tool, Valve Stem Seal (Appendix B, Item 3)
Torque Wrench (Appendix B, Item 3)
Compressor, Air (Appendix B, Item 3)
Caliper, Slide (Appendix B, Item 3)
Micrometer (Appendix B, Item 3)

Material's Required

Abrasive Cloth (Appendix E, Item 5)
Diesel Fuel (Appendix E, Item 6)
Lubricating Oil (Appendix E, Item 7)
Equipment Condition
DED pump assembly shut down and cool.
Inlet enclosure removed (See paragraph 4-22).

a. Removal. (Refer to Figure 5-4).

- (1) Remove plunger (1), holder (2), two screws (3), cylinder head cover (4), and gasket (5).
- (2) Remove two cap nuts (6) and washers (7) from cylinder head studs (8).
- (3) Remove two cylinder head nuts (9) and cylinder head washers (10) from cylinder head studs (11).
- (4) Remove cylinder head assembly (12) by lifting straight up off the four cylinder head studs (8 and 11).
- (5) Remove and discard push rod O-ring (13) and cylinder head gasket (14).

CAUTION

Keep intake and exhaust push rods separate. Switching push rods may damage engine.

- (6) Tag and remove push rods (15).

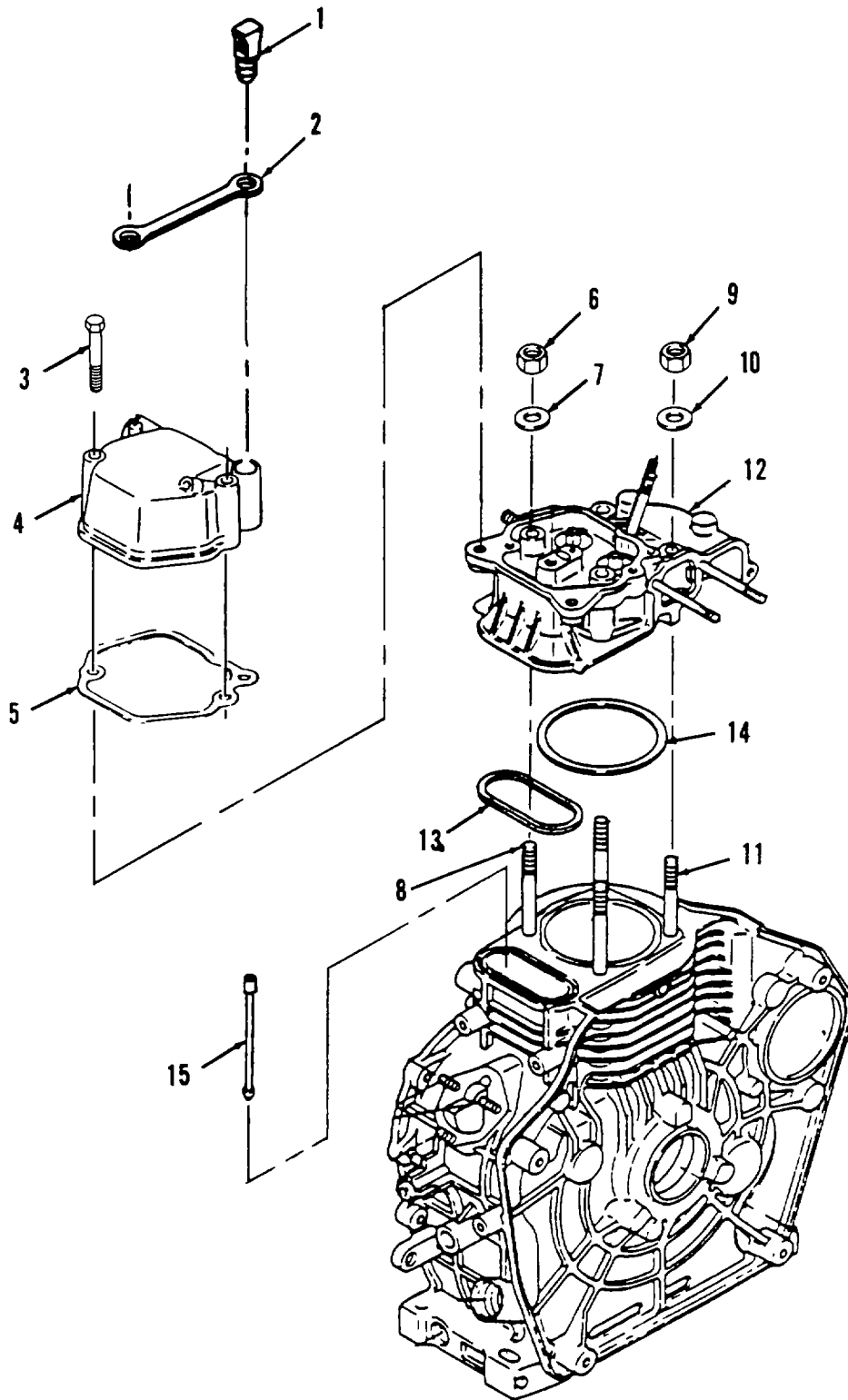

Figure 5-4. Cylinder Head Removal.

5-10. CYLINDER HEAD ASSEMBLY REPAIR AND REPLACEMENT. - Continued.

b. Disassembly. (Refer to Figure 5-5.)

- (1) Remove rocker arm support bolt (1).
- (2) Remove rocker arm support (2) with intake and exhaust valve rocker arms (3 and 4) attached.
- (3) Remove valve stem caps (5).

WARNING

Serious injury can be caused by the sudden release of spring loaded parts.
Use extreme caution when removing valve springs.

- (4) Compress valve spring (6), and remove retainer keeper (7) and retainer (8) from top of valve spring
- (6).
- (5) Remove valve spring (6).
 - (6) Remove valve spring washer (9).
 - (7) Remove valves (10 and 11) from cylinder head.
 - (8) Remove valve seals (12) from cylinder head and discard.

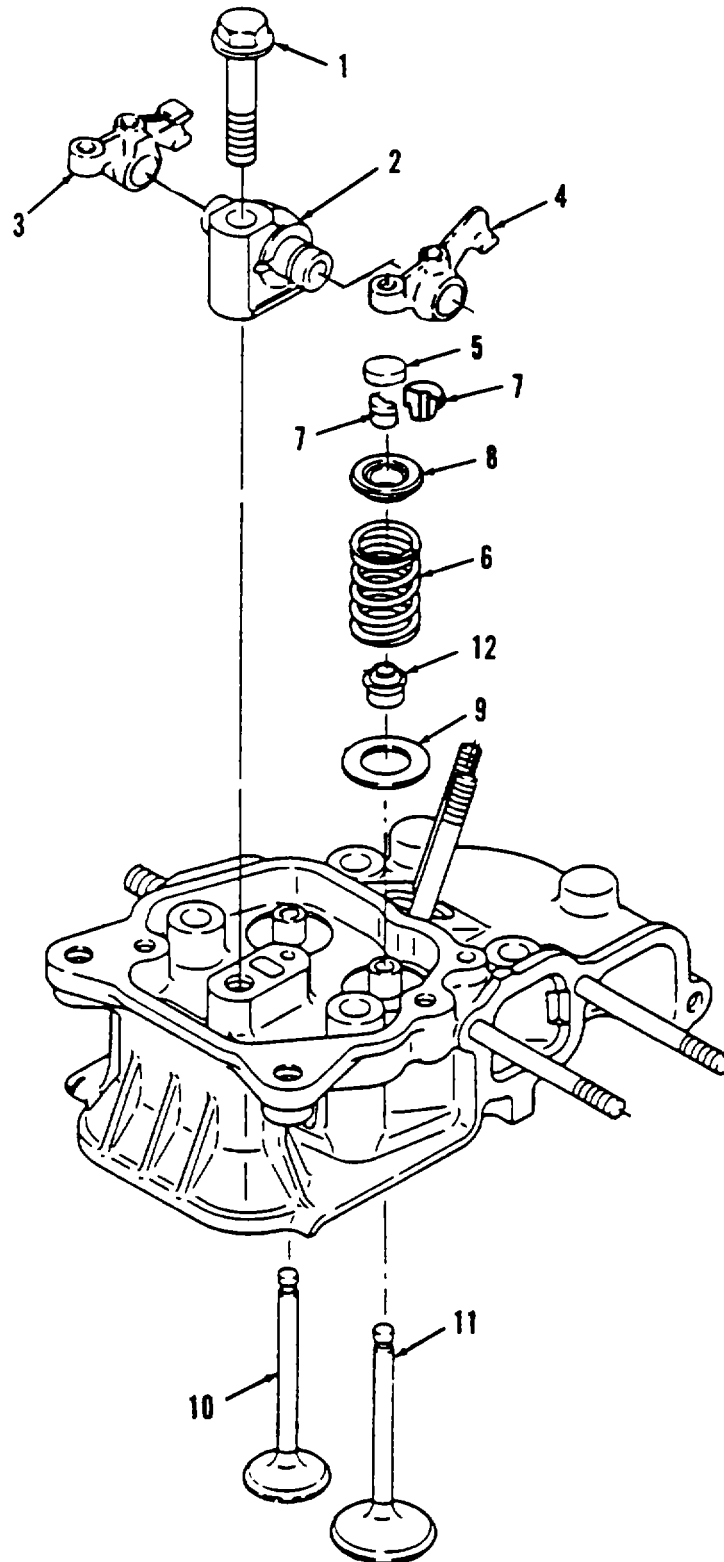

Figure 5-5. Cylinder Head Disassembly.

5-10. CYLINDER HEAD ASSEMBLY REPAIR AND REPLACEMENT. - Continued.**c. Inspection.****WARNING**

Death or serious injury could occur if compressed air is directed against skin. Do not use compressed air for cleaning or drying unless the pressure is/has been reduced to 30 PSI or less. When working with compressed air, always use eye protection and any other protective equipment.

CAUTION

- Do not confuse the intake and exhaust valve stems.
- The intake/exhaust valve guides are provided with a valve stem seal. Valve stem seals cannot be reused and must be replaced with new ones.
- When inserting the intake and exhaust valve stems, apply lube oil to the valve stems.

(1) Clean cylinder head and valves with a clean cloth dampened with diesel fuel. Use wire brush where necessary and dry with compressed air.

(2) Inspect cylinder head for cracks, corrosion, or excessive heat damage.

(3) Inspect valve heads and valve stems for cracks, pitting, scratches, warpage, or any other damage.

(4) Refer to Figure 5-6. Check that each valve stem diameter is more than 0.2126 inch (5.40 mm).

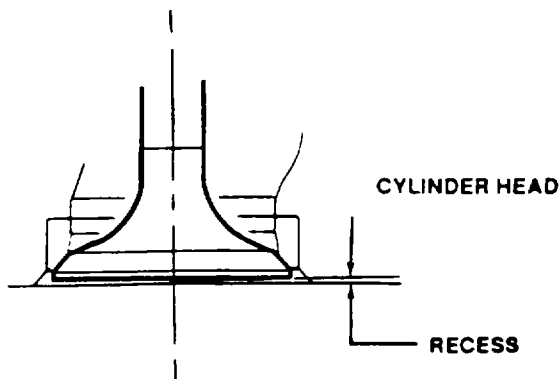

Figure 5-6. Valve Recess.

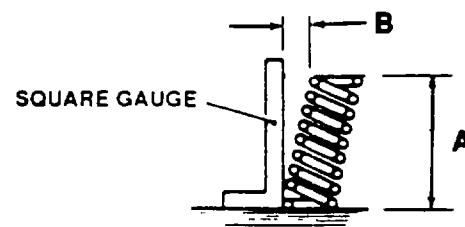

Figure 5-7. Spring Inclination.

(5) Reinsert valves into the cylinder head and check that each valve recess is less than 0.043 inch (1.1 mm).

(6) Check that the inside diameter of each valve guide does not exceed 0.2197 inch (5.58 mm).

(7) Clean off carbon deposits on the valve seats since carbon buildup, excessive wear, and corrosion can cause compression leaks.

(8) Replace cylinder head if any of the following conditions exist:

If cylinder block contact surface is roughened or not level; if the valve seats are worn; if the valve rocker arm cover contact surface is rough or damaged; or if there are cracks between the valve seats.

(9) Check the valve spring for flaw or corrosion.

(10) Refer to Figure 5-7. Check that the valve spring free length (dimension A) is more than 1.043 inches (26.5 mm).

(11) Check that the spring inclination (how far spring inclines to the left or right, dimension B) is less than 0.030 inch (0.75 mm).

(12) Check that the OD of the valve rocker arm support shaft is more than 0.4685 inch (11.90 mm).

(13) Check that the ID of the valve rocker arm does not exceed 0.4764 inch (12.1 mm).

(14) Check for bending of the push rods.

(15) Inspect and clean thoroughly the gasket and O-ring areas of cylinder head and crankcase.

(16) Inspect studs (8) and (11). Replace if threads are stripped or broken.

d. Repair.

(1) Replace any components that do not meet inspection criteria.

(2) Remove slight scratches or scuff marks with crocus cloth.

e. Assembly. (Refer to Figure 5-5).

(1) Insert new valve stem seals onto valve guide.

(2) Insert valves (10 and 11) into cylinder head.

(3) Install valve spring washer (9).

(4) Install valve springs (6).

(5) Compress valve spring (6) and install retainer (8) and retainer keeper (7).

f. Installation.

(1) Refer to Figure 5-4. Place new cylinder head gasket (14) and push rod O-ring (13) onto cylinder block.

(2) Install cylinder head (12) onto four studs (8) and (11) protruding from cylinder block.

(3) Position push rods (15) into cylinder block in the cam followers.

5-10. CYLINDER HEAD ASSEMBLY REPAIR AND REPLACEMENT. - Continued.**f. Installation. - Continued.**

- (4) Secure cylinder head (12) to cylinder block using two nuts (9), two washers (10), two nuts (6), and two washers (7).
- (5) Tighten nuts using torque wrench to 20-23 ft-lb (280-320 kg-cm).
- (6) Refer to Figure 5-5. Install valve stem caps (5).

NOTE

Rocker arm with flat head is for the exhaust valve only.

- (7) Install rocker arm support (2) with intake and exhaust valve rocker arms attached.
- (8) Tighten rocker arm support bolt (1) with torque wrench to 14.5-16.6 ft-lb (200-230 kg-cm).
- (9) Refer to Figure 5-4. Install gasket (5), cylinder head cover (4), two screws (3), holder (2), and plunger (1).

g. Adjustment. (Refer to Figure 5-8).**NOTE**

Valve clearance should be adjusted when engine is cold.

- (1) Turn flywheel so "T" mark on flywheel aligns with alignment mark on cylinder block.
- (2) Slightly rotate flywheel (approximately 20 degrees in both directions). If valves move up and down, this is the exhaust top dead center. Do not adjust the valve clearance with the flywheel in this position.
- (3) Give flywheel another turn until ""T" mark on flywheel aligns with alignment mark on cylinder block. Slightly rotate flywheel (approximately 20 degrees in both directions). If valves do not move up and down, the flywheel is in correct position to check valve clearance.
- (4) Check that "T" mark and alignment mark are aligned correctly.
- (5) Insert screwdriver into adjusting bolt and loosen locknut. Refer to Figure 5-9.
- (6) Turn screwdriver counterclockwise to obtain a clearance. Move valve lever inside for adjustments.
- (7) Insert feeler gauge between valve rocker arm and top of the valve spring cotter.
- (8) While turning the adjusting screw clockwise, slowly slide the feeler gauge back and forth. Stop turning adjusting screw when slight resistance is felt on the feeler gauge.
- (9) Remove feeler gauge and tighten locknut. Keep screwdriver inserted into adjusting screw to prevent adjusting screw from turning.
- (10) Verify valve clearance of 0.006 inch (0.15 mm) after completion.

- (11) Repeat on both intake and exhaust valves.
- (12) After securing both locknuts, check that clearance is still 0.006 inch (0.15 mm).

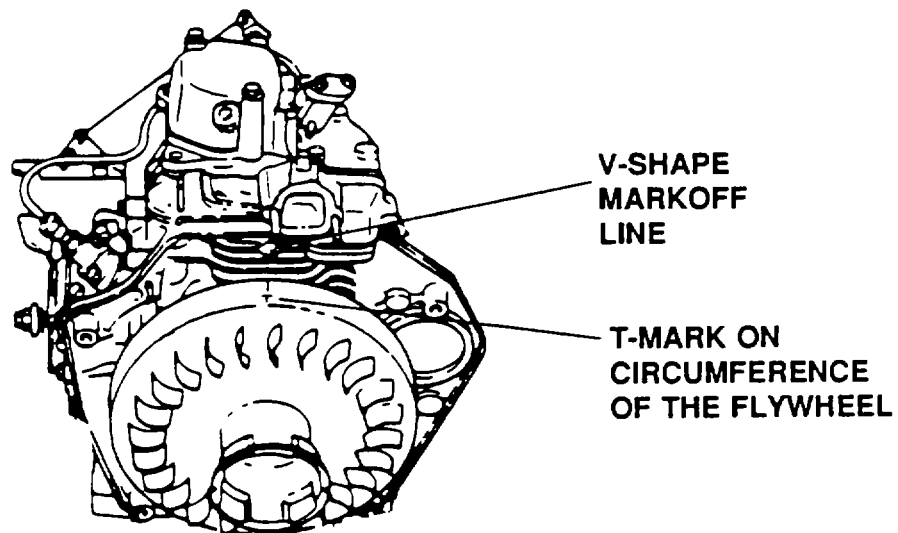

Figure 5-8. Alignment of Flywheel With Cylinder Block.

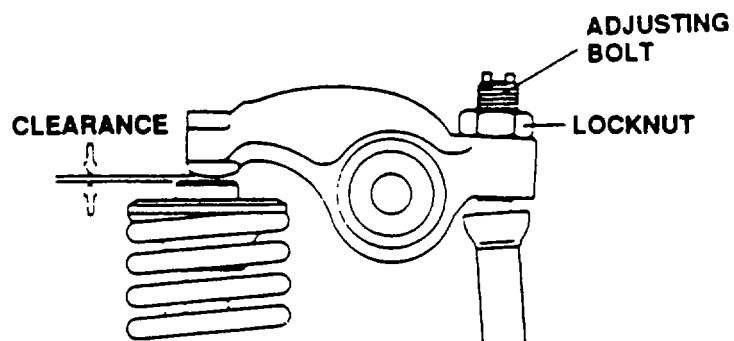

Figure 5-9. Adjusting Valve Clearance.

5-11. FLYWHEEL REPLACEMENT.

This Task Covers:

- a. Removal b. Installation
-

Initial Setup:**Tools Required**

Tool Kit, General Mechanic's (Appendix B, item 1)
Puller (Appendix B, Item 3)
Torque Wrench (Appendix B, Item 3)

Material's Required

None

Equipment Condition

DED pump assembly shut down and cool.
Cooling fan case removed (see paragraph 4-33).

a. Removal. (Refer to Figure 5-10).

- (1) Remove starter pulley (1) by removing three bolts (2).
- (2) Brace the flywheel (5) to prevent the flywheel from turning while loosening the flywheel nut (3) by inserting a pry bar through a hole in the flywheel into the depression in the crankcase.
- (3) Remove flywheel end nut (3) and washer (4) from crankshaft (6).
- (4) Using a puller, remove flywheel.

CAUTION

Be careful not to damage the taper part of the crankshaft.

- (5) Remove flywheel key (7) from crankshaft (6)

b. Installation.

- (1) Install flywheel key (7) onto crankshaft (6).
- (2) Install flywheel (5) onto crankshaft (6).
- (3) Install flywheel end nut (3) and washer (4).
- (4) Tighten flywheel end nut (3) after bracing the flywheel by inserting a pry bar through a hole in the flywheel into the depression in the crankcase. Torque flywheel end nut to 73-80 ft-lb (1000-1100 cm-kg).
- (5) Install starter pulley (1) and three bolts (2).

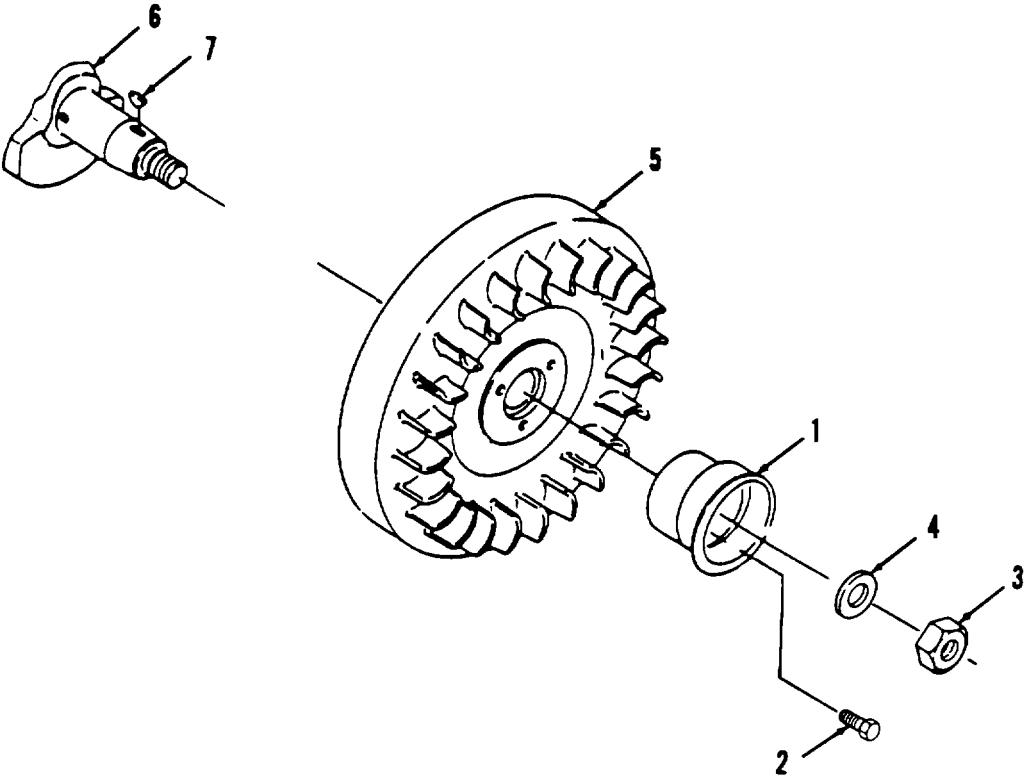

Figure 5-10. Flywheel Replacement.

CHAPTER 6

GENERAL SUPPORT MAINTENANCE INSTRUCTIONS

SECTION I. GENERAL SUPPORT REPAIR PARTS, SPECIAL TOOLS, TEST MEASUREMENT AND DIAGNOSTIC EQUIPMENT (TMDE), AND SUPPORT EQUIPMENT

6-1. COMMON TOOLS AND EQUIPMENT. For authorized common tools and equipment, refer to the Modified Table of Organization and Equipment (MTOE) applicable to your unit.

6-2. SPECIAL TOOLS, TMDE, AND SUPPORT EQUIPMENT. The special tools required to service the centrifugal pump are listed and illustrated in TM10-4320-316-24P, Repair Pars and Special Tools List (RPSTL), and in the Maintenance Allocation Chart (MAC) located in Appendix B of this manual.

6-3. REPAIR PARTS. Repair parts are listed and illustrated in TM10-4320-316-24P.

SECTION II. GENERAL SUPPORT MAINTENANCE PROCEDURES

6-4. GENERAL SUPPORT MAINTENANCE PROCEDURES. Maintenance procedures at general support maintenance level include as necessary: removal, cleaning and inspection, repair or replacement, and installation. Unless the procedure requires special resources or tools, more than one maintenance person or specific equipment conditions, these are not listed for each maintenance procedure. They are listed only for those procedures that require them.

6-5. CRANKCASE ASSEMBLY REPAIR AND REPLACEMENT.

This Task Covers:

- a. Removal b. Inspection c. Repair d. Installation
-

Initial Setup:**Tools Required**

Tool Kit, General Mechanic's (Appendix B, item 1)
Caliper, Slide (Appendix B, Item 3)
Bearing Puller (Appendix B, Item 3)
Torque, Wrench (Appendix B, Item 3)

Material's Required

Lubricating Oil (Appendix E, Item 8)
Diesel Fuel (Appendix E, Item 6)
Oil Seal Gasket, 114250-01412

Equipment Condition

DED pump assembly shut down and cool.
Bottom pan frame removed (see paragraph 4-25).

- a. **Removal.** (Refer to Figure 6-1).

CAUTION

Oil pump cover and oil filter cover do not have to be disassembled to remove crankcase cover and should only be disassembled when necessary.

- (1) Remove fourteen crankcase cover bolts (1).
- (2) Remove one additional crankcase cover bolt (2) located inside of the bolt pattern and above the lube oil strainer.
- (3) Remove crankcase cover (3) and discard gasket (4).
- (4) Remove and discard oil seal (5).
- (5) Remove lube oil inlet pipe (6) from crankcase cover (3).

b. **Inspection.**

- (1) Clean out each oil hole on the crankcase cover with diesel fuel. Insure oil passages are not clogged.
- (2) Check the main bearing metal insert on the crankcase side for discoloration or damage.

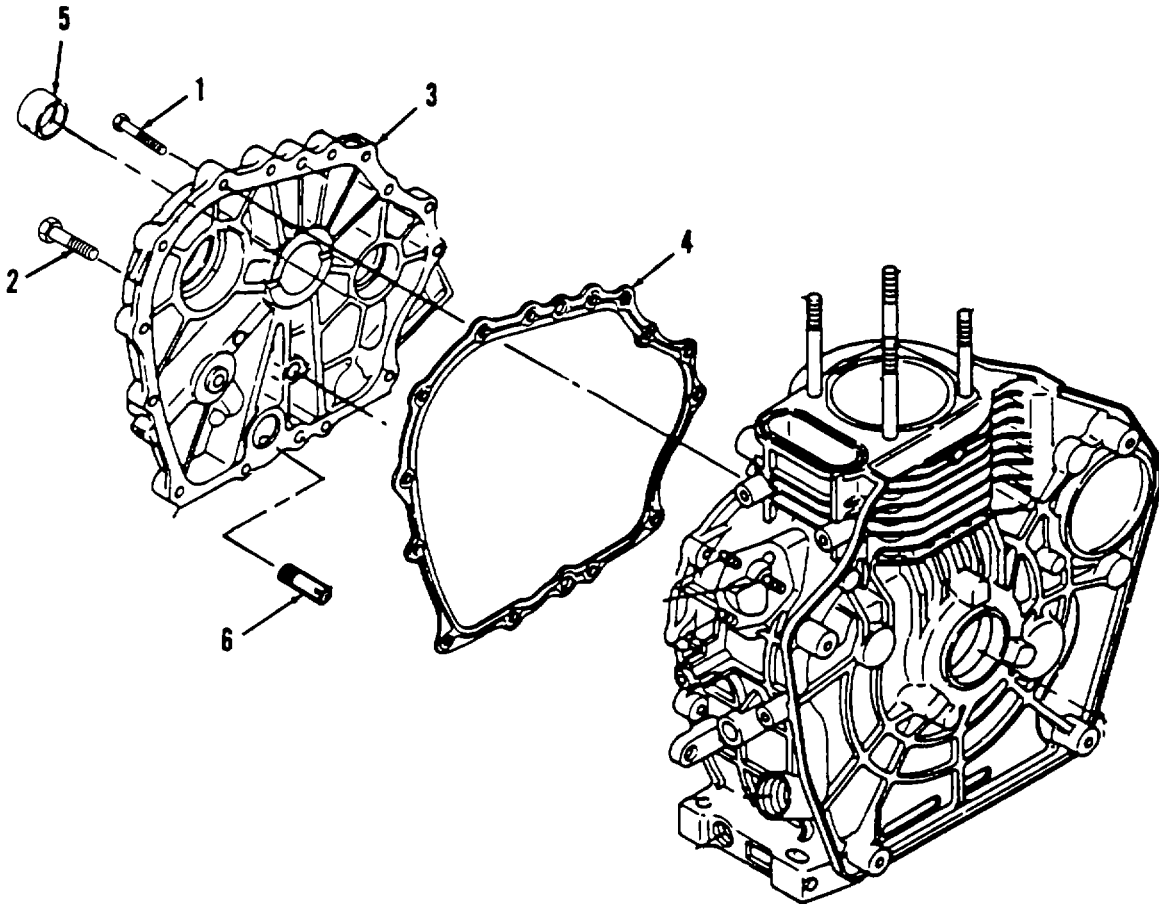
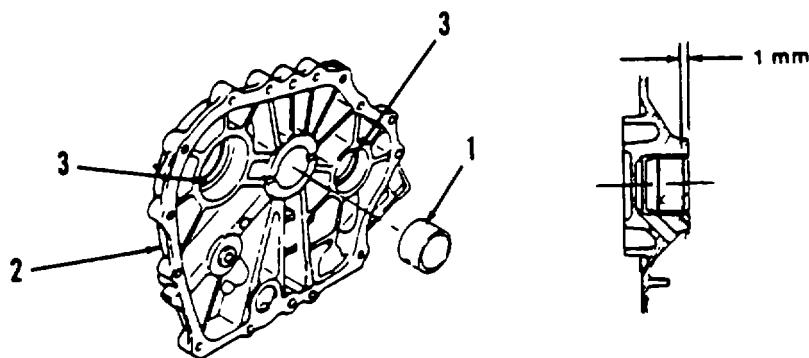

Figure 6-1. Crankcase Cover Replacement.

6-5. CRANKCASE ASSEMBLY REPAIR AND REPLACEMENT. - Continued.**c. Repair.**

- (1) Replace the main bearing metal insert if it is discolored or damaged.
 - (a) Remove bad main bearing metal insert (1).
 - (b) Insert main bearing (1) into crankcase cover (2). Carefully fit the main bearing so that the oil groove is in the upper half and the oil hole in the bearing is aligned with the oil groove.
 - (c) Press fit the main bearing until recess is 0.0039 inch (1 mm) past the cover edge.

**Figure 6-2. Main Bearing Insert Removal.**

- (2) Replace the camshaft ball bearing or the balance shaft ball bearing.
 - (a) Remove bad bearing (3) using a mechanical bearing puller.
 - (b) Press fit the new ball bearing (3) into the crankcase cover (2).
- (3) Refer to Figure 6-2. Replace crankshaft oil seal.
 - (a) Insert new crankshaft oil seal (5) into crankcase cover (3).
 - (b) Insert crankshaft seal into crankcase cover until it is 0.1575 inch (4 mm) deep from the end of crankcase.
- (4) Replace crankcase cover gasket (4).

b. Installation. (Refer to Figure 6-1).

- (1) Install lube oil inlet pipe (6) into crankcase cover (3).
- (2) Place a crankcase cover gasket (4) between the surface of the crankcase and the crankcase cover (3).
- (3) Apply oil to the lips of oil seal (5).
- (4) Apply lubricating oil to crankshaft and camshaft.
- (5) Make sure that the oil pump drive gears are properly engaged.
- (6) Carefully guide the crankcase cover (3) over the crankshaft and insure that the seal seats properly.
- (7) Attach crankcase cover (3) to the cylinder block using 14 bolts (1) plus additional bolt (2) located above the lube oil strainer.
- (8) Refer to Figure 6-3. Tighten bolts in sequence shown and torque to 72-96 in-lb (83-110 kg-cm).

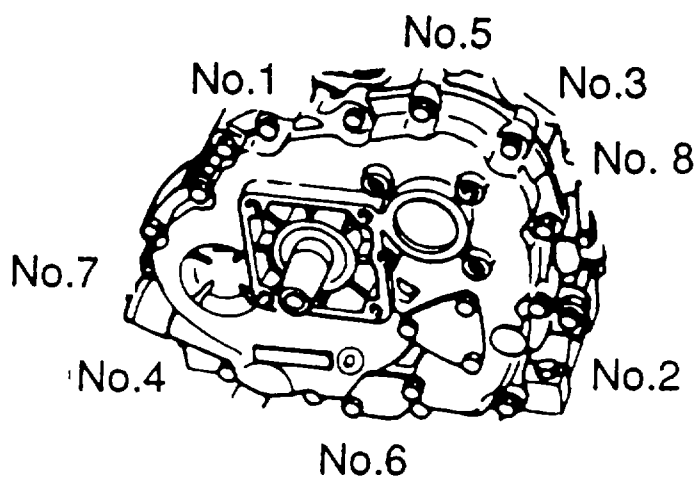

Figure 6-3. Tightening Sequence for Crankcase Cover Bolts.

6-6. PISTON AND CONNECTING ROD ASSEMBLY REPAIR AND REPLACEMENT.

This Task Covers:

- a. Removal b. Inspection c. Repair d. Installation
-

Initial Setup:**Tools Required**

Tool Kit, General Mechanic's (Appendix B, item 1)
Snap Ring Pliers (Appendix B, Item 3)
Piston Ring Expander (Appendix B, Item 4)
Piston Ring Groove Cleaner (Appendix B, Item 4)
Piston Ring Compressor (Appendix B, Item 4)
Torque Wrench (Appendix B, Item 3)
Gloves (Appendix B, Item 3)

Materials Required

Diesel Fuel (Appendix E, Item 6)
Lubricating Oil (Appendix E, Item 8)
Plastigage, PG-1 (Appendix E, Item 9)

Equipment Condition

DED pump assembly shut down and cool.
Camshaft removed (see paragraph 6-9)
Balancer shaft removed (see paragraph 6-8)

a. Removal. (Refer to Figure 6-4).

- (1) Remove carbon deposited on the upper inside surface of the cylinder before extracting the piston.
- (2) Remove two connecting rod mounting bolts (1), nuts (2), and washers (3).
- (3) Remove connecting rod cap (4).
- (4) Rotate crankshaft to the top of the piston stroke and pull out piston (5).
- (5) Remove both snap lock rings (6).

WARNING

Heated parts can result in severe burns Exercise care in handling the heated parts.

CAUTION

Avoid heating piston directly with a torch.

- (6) Heat piston (5) and piston pin (7) to 160-180°F.
- (7) Remove piston pin (7) from piston (5).
- (8) Connecting rod (8) can now be separated from piston.

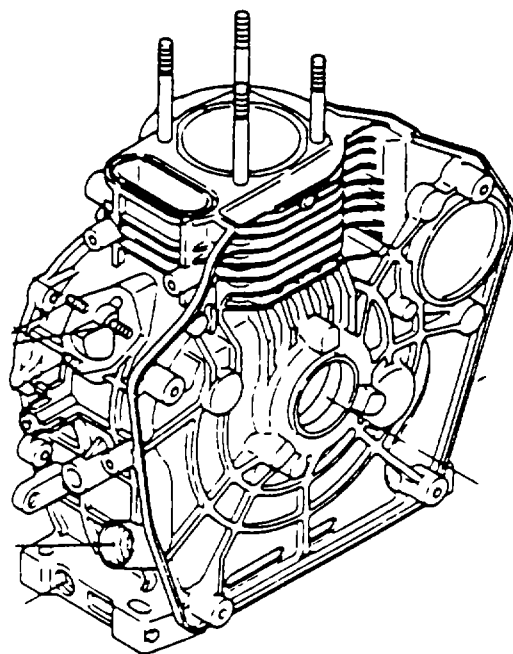
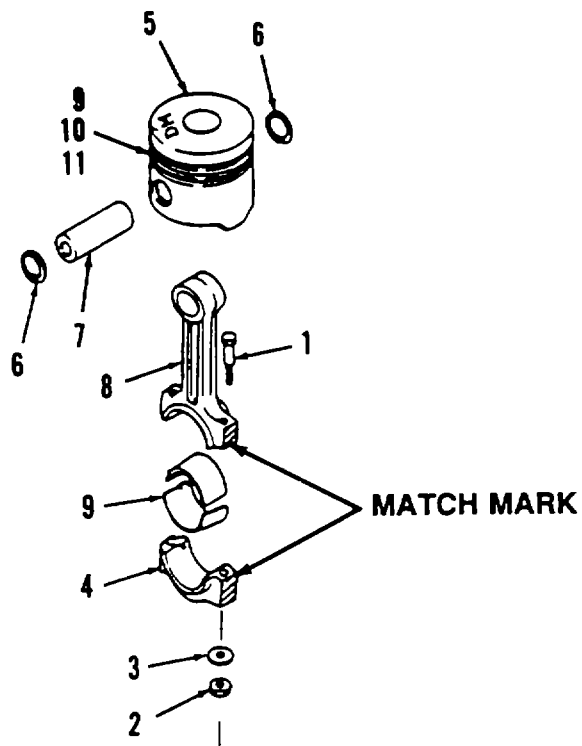

Figure 6-4. Piston and Connecting Rod Assembly Replacement.

6-6. PISTON AND CONNECTING ROD ASSEMBLY REPAIR AND REPLACEMENT. - Continued.**a. Removal.** - Continued.**CAUTION**

Piston ring breakage may occur if rings are opened more than necessary when removing. Never stretch piston rings more than necessary.

- (9) Use the piston ring remover tool to remove piston rings (9), (10), and (11). Discard piston rings.

NOTE

Prior to inspecting/evaluating the piston and connecting rod assembly, evaluate the cylinder. Check that the cylinder ID is no greater than 2.684 inches (68.16 mm). If the cylinder sleeve is greater than this wear limit, follow the procedures to replace the crankcase.

b. Inspection.

- (1) Clean piston (5) and piston pin (7).
- (2) Remove carbon from piston and piston components.
- (3) Carefully clean the piston ring groove after the piston rings have been removed.
- (4) Inspect piston, piston skirt, piston grooves, and piston pin for excessive wear, discoloration, and damage. Replace damaged piston.

NOTE

Before reading any measurements, all carbon buildup must be removed. Carbon buildup will cause unreliable measurements.

- (5) Check that the OD of piston is greater than 2.665 inches (67.68 mm). Measure piston OD 90 degrees from the piston pin hole and about 0.50 inch (12 mm) from the bottom of piston. Replace piston if worn beyond the wear limit.
- (6) Check that the ID of the piston pin hole is less than 0.751 inch (19.07 mm). Replace piston if ID exceeds wear limit.
- (7) Check that the OD of the piston pin is greater than 0.745 inch (18.92 mm). Replace piston pin if OD is worn beyond the wear limit.
- (8) Clean connecting rod components with diesel fuel.
- (9) Inspect all connecting rod components for bending, warping, cracking, excessive wear, or any other damage. Replace any components damaged or worn.
- (10) Check that piston pin hole ID (small end hole) of connecting rod is less than 0.752 inch (19.1 mm). Replace connecting rod if piston pin hole diameter exceeds wear limit.
- (11) Check that crank pin hole ID (large end hole) of connecting rod is less than 1.184 inches (30.08 mm). Replace connecting rod if crank pin hole diameter exceeds wear limit.

(12) Check the thrust surface on both ends of the connecting rod for damage. Replace connecting rod if necessary.

(13) Check the contact surface of the crank pin bearing insert for separation, melting, seizure, etc. Replace crank pin bearing insert if it is separated or damaged.

(14) Check that clearance between crank pin and crank pin bearing insert is less than 0.004 inch (0.12 mm). Replace crankpin bearing insert if clearance exceeds wear limit.

c. **Repair.** Repair is limited to replacement of defective parts.

d. **Installation.**

WARNING

Heated parts can result in severe burns. Exercise care in handling the heated parts.

CAUTION

Connecting rod is made of a special aluminum alloy. Avoid damage while handling. Do not drop or clash against a hard object.

CAUTION

Avoid direct heating of piston with a torch.

- (1) Heat piston (5) to 160-180°F.
- (2) Position the piston top identification mark "DM" (12) and the ID number on the connecting rod as shown.
- (3) Align the small end hole of connecting rod (8) with the piston.
- (4) Insert piston pin (7) into the piston pin hole.
- (5) Insert two snap lock rings (6) into piston pin holes.

NOTE

Any time piston is removed from engine, new piston rings should be installed.

- (6) Measure piston ring end gap of each piston ring.
- (7) When inserting the rings, the identification mark should face up.

CAUTION

Piston ring breakage may occur if rings are opened more than necessary when installing. Never stretch piston rings more than necessary.

NOTE

The top piston ring will have a "T" on the top surface. The middle piston ring will have a "2T" on the top surface and the bottom piston ring will have a "1" on the top surface.

- (8) Use the piston ring remover tool to install piston rings (9), (10), and (11). Install oil ring, 2nd compression ring, and 1st compression ring in order.

6-6. PISTON AND CONNECTING ROD ASSEMBLY REPAIR AND REPLACEMENT. - Continued.**d. Installation.** - Continued.

- (9) Make sure each piston ring gap is 120 degrees.
- (10) Make sure the piston rings move smoothly.

NOTE

Cylinder walls should have a deglazed and cross-hatched pattern. The surface should be clean and dry.

- (11) Apply liberal amount of lubricating oil to the outer surface of the piston and inner surface of the cylinder.
- (12) Align the identification mark DM on the piston head with the mark on the crankcase.
- (13) Install new connecting rod bearing insert (14) into connecting rod (8).
- (14) Apply oil to the crank pin on the crankshaft.

CAUTION

Connecting rod is made of a special aluminum alloy. Avoid damage while handling. Do not drop or clash against a hard object.

(15) Insert the piston and connecting rod assembly into the cylinder using a piston ring compressor, and move the crankshaft to top dead center. The identification mark DM on the piston head should align with the mark on the cylinder block.

(16) Insert connecting rod end cap bearing insert (14) into connecting rod end cap (4).

(17) Install the connecting rod cap (4) using bolts (1), washers (3), and nuts (2). Rotate flywheel so piston is at bottom dead center. Tightening torque for connecting rod bolts is 13.0-14.5 ft-lb (190-200 cm-kg).

6-7. GOVERNOR ASSEMBLY AND LUBE OIL PUMP REPAIR AND REPLACEMENT.

This Task Covers:

- a. Removal b. Inspection c. Repair d. Installation
-

Initial Setup:**Tools Required**

Tool Kit, General Mechanic's (Appendix B, item 1)

Materials Required

Diesel Fuel (Appendix E, Item 6)

Equipment Condition

DED pump assembly shut down and cool.
Crankshaft removed (see paragraph 6-10).

a. Removal.**(1) Governor Assembly Removal.** (Refer to Figure 6-5).

- (a) Remove governor lever taper pin (1).
- (b) Remove governor lever (2).
- (c) Remove governor control arm (3) and governor shaft (4) from inside the engine.
- (d) Remove governor control arm lever taper pin (5).
- (e) Remove governor control arm (3) from the governor shaft (4).
- (f) Remove thrust bushing (6).
- (g) Remove needle bearing (7) and washer (8).
- (h) Remove nut (9) from fuel limiting adjustment (10).
- (i) Remove fuel limiting adjustment (10) from crankcase.

(2) Lube Oil Pump Removal. (Refer to Figure 6-6).

- (a) Remove three lube oil pump cover bolts (1) holding lube oil pump cover (2).
- (b) Remove lube oil pump cover (2) and O-ring (3). Discard O-ring.
- (c) Lay crankcase cover on clean, flat surface.
- (d) Grasp hold of the plastic gear (4) and carefully pull spindle (5) from lube oil pump shaft.
- (e) Remove drive pin (6).
- (f) Remove lube oil pump shaft (7) and outer rotor (8) from crankcase cover.

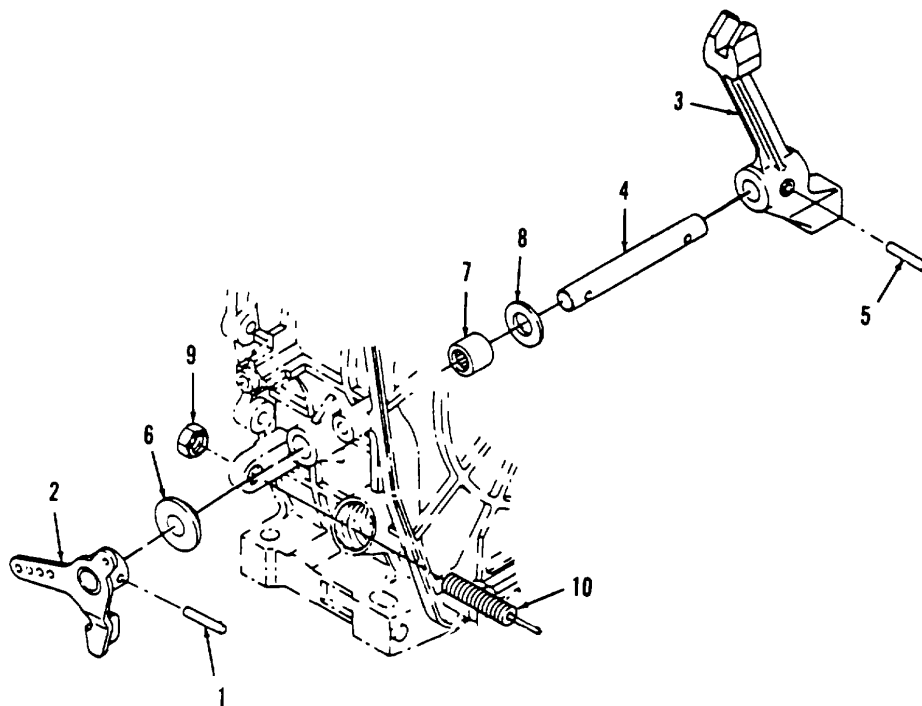

Figure 6-5. Governor Assembly Removal.

b. Inspection.

- (1) Clean all parts with diesel fuel.
- (2) Inspect all components for damage or excessive wear. Replace any components damaged or worn.
- (3) Check that the outside diameter of the outer rotor is at least 1.138 inches (28.90 mm).
- (4) Check that the crankcase cover housing inside diameter is less than 1.149 inches (29.18 mm).
- (5) Check that the clearance between housing ID and outer rotor OD is between 0.005-0.011 inch (0.120-0.280 mm).
- (6) Check that outer rotor and inner rotor width is at least 0.311 inch (7.90 mm).
- (7) Check that the crankcase cover housing depth is less than 0.319 inch (8.10 mm).
- (8) Check that the clearance between the inner and outer rotor is less than 0.010 inch (0.25 mm).

6-7. GOVERNOR ASSEMBLY AND LUBE OIL PUMP REPAIR AND REPLACEMENT. - Continued.

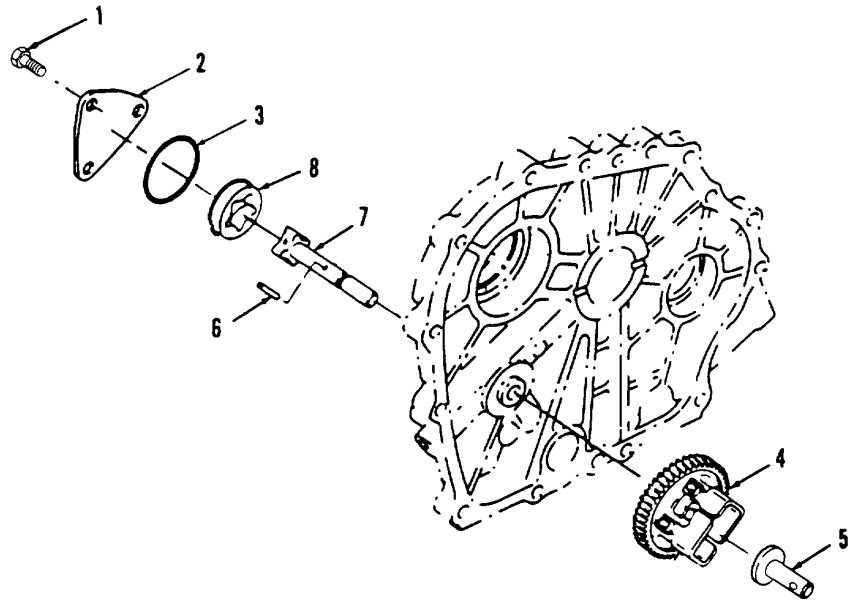

Figure 6-6. Lube Oil Pump Repair and Replacement.

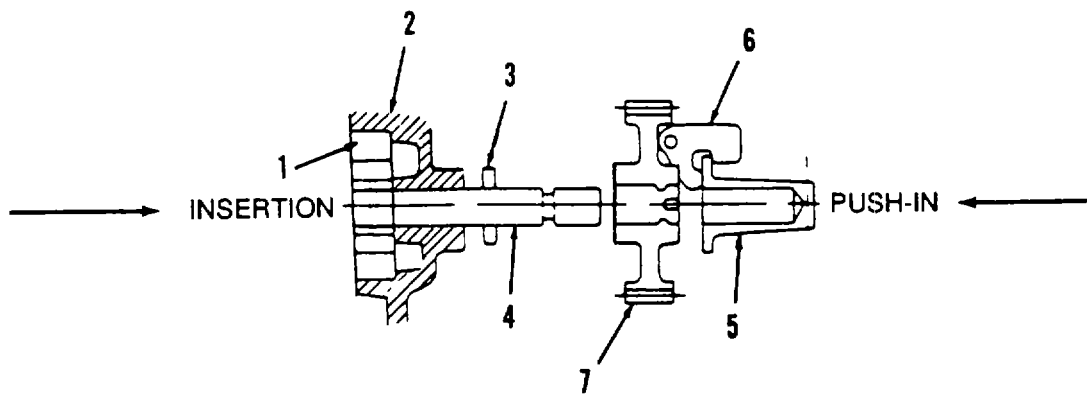

Figure 6-7. Lube Oil Pump Installation.

c. Repair. Repair is limited to the replacement of defective parts as described in the following steps.

- (1) Replace lube oil pump if the OD of the outer rotor is less than 1.138 inches (28.9 mm).
- (2) Replace crankcase cover if the housing ID is greater than 1.149 inches (29.18 mm).
- (3) Replace the lube oil pump if the clearance between housing ID and outer rotor OD is greater than 0.011 inch (0.280 mm).
- (4) Replace lube oil pump if the outer and inner rotor width is less than 0.311 inch (7.9 mm).
- (5) Replace crankcase cover if the housing depth is greater than 0.319 inch (8.1 mm).
- (6) Replace lube oil pump if the clearance between the inner and outer rotor is less than 0.010 inch (0.25 mm).

d. Installation.

(1) Lube Oil Pump.

(a) (Refer to Figure 6-7). Insert lubricating oil pump assembly (1) from the outside of the crankcase cover (2). Coat the rotor with oil before installing the cover.

(b) Insert drive pin (3) into the lubricating oil pump shaft (4).

(c) Insert spindle (5) into the weights (6) on the governor gear assembly (7), then push the governor gear assembly (7) onto the oil pump shaft (4). Ensure that gear is firmly engaged onto pin (3). (d) (Refer to Figure 6-6). Install new O-ring (3) onto crankcase cover and secure oil pump cover (2) with 3 bolts (1).

(2) Governor Assembly. (Refer to Figure 6-5).

(a) Install fuel limiting adjustment (10) into crankcase.

(b) Install nut (9) onto fuel limiting adjustment (10).

(c) Install needle bearing (7) into cylinder block.

(d) Insert shaft (4) into governor control arm (3) and lock into position with taper pin (5).

(e) Install governor control arm (3), shaft (4), and washer (8) into needle bearing in engine from the inside.

(f) Insert thrust bushing (6) onto shaft (4) in cylinder block.

(g) Install control arm lever (2) onto shaft (4) and insert taper pin (1) into shaft.

(h) After engine has been reassembled, adjust engine speed control device per paragraph 5-9.

6-8. BALANCER SHAFT ASSEMBLY REPLACEMENT.

This Task Covers:

- a. Removal b. Installation
-

Initial Setup:**Tools Required**

Tool Kit, General Mechanic's (Appendix B, item 1)

Materials Required

Diesel Fuel (Appendix E, Item 6)

Equipment Condition

DED pump assembly shut down and cool.
Crankcase cover removed (see paragraph 6-5).

a. Removal. (Refer to Figure 6-8).

- (1) Check the location of the timing marks on all gears.
- (2) Remove the balancer shaft (1).

b. Installation.

- (1) Insert the balancer shaft assembly (1) into the cylinder block (2).
- (2) Refer to Figure 6-9. Make sure the timing marks (1) on the balancer gear (2) and the crank gear (3) are aligned.

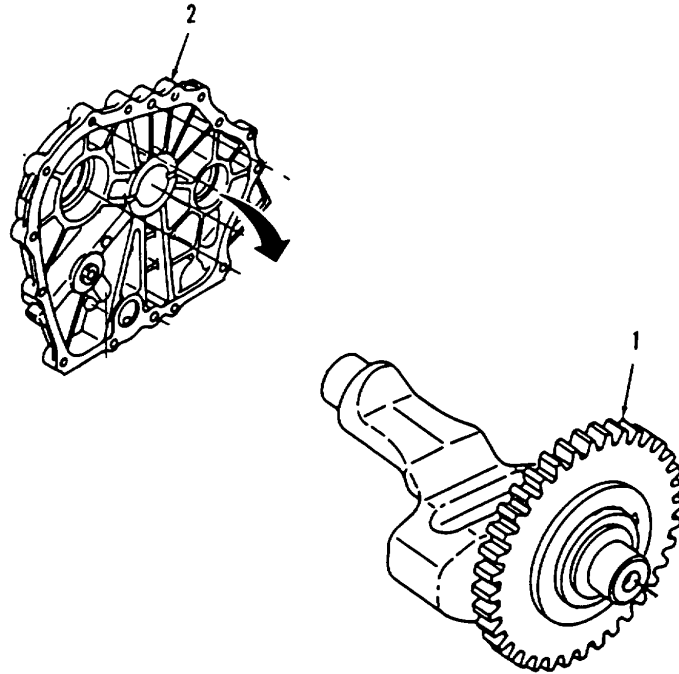

Figure 6-8. Balancer Shaft Removal.

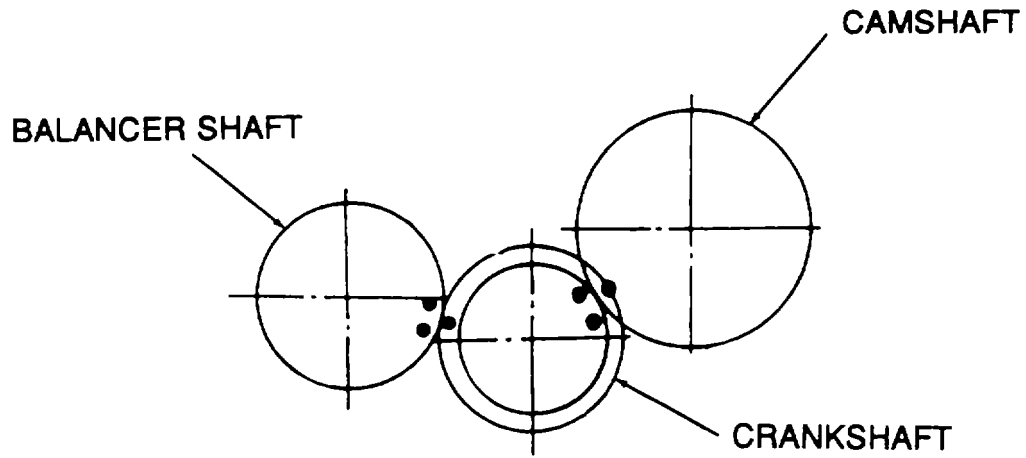

Figure 6-9. Rotating Group Timing Marks.

6-9. CAMSHAFT ASSEMBLY REPLACEMENT.

This Task Covers:

- a. Removal b. Installation
-

Initial Setup:**Tools Required**

Tool Kit, General Mechanic's (Appendix B, item 1)
Micrometer Set (Appendix B, Item 3)
Arbor Press (Appendix B, Item 3)

Materials Required

Diesel Fuel (Appendix E, Item 6)

Equipment Condition

DED pump assembly shut down and cool.
Fuel injection pump removed. (see paragraph 4-34).
Cylinder head and valve assembly removed (see paragraph 5-10).
Crankcase cover removed (see paragraph 6-5).

- a. **Removal** (Refer to Figure 6-10).

CAUTION

Keep exhaust and intake tappets separate. They may fall down when pulling out the camshaft and may be confused.

- (1) Check the location of the timing marks on all gears.
- (2) Lay engine down on the flywheel side to prevent tappets from falling out
- (3) Pull out the camshaft (1) from engine (2).

- b. **Installation.**

CAUTION

Keep the intake and exhaust tappets separate and return into same location at reassembly.

- (1) Insert the intake and exhaust valve tappets into the cylinder block.
- (2) Insert the camshaft assembly (1) into the cylinder block.
- (3) Refer to Figure 6-11. Align timing marks on the cam gear (1) and crank gear (2).

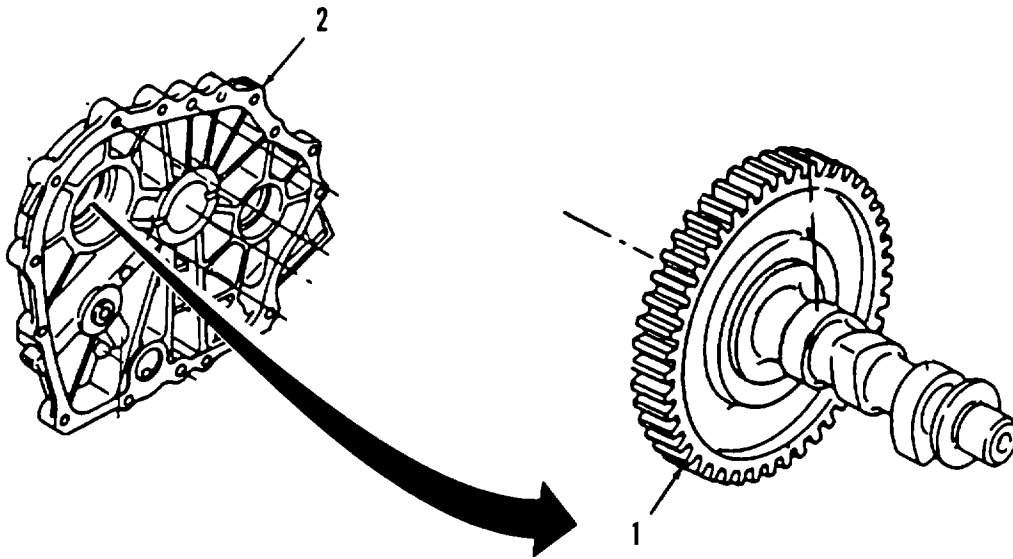

Figure 6-10. Camshaft Removal.

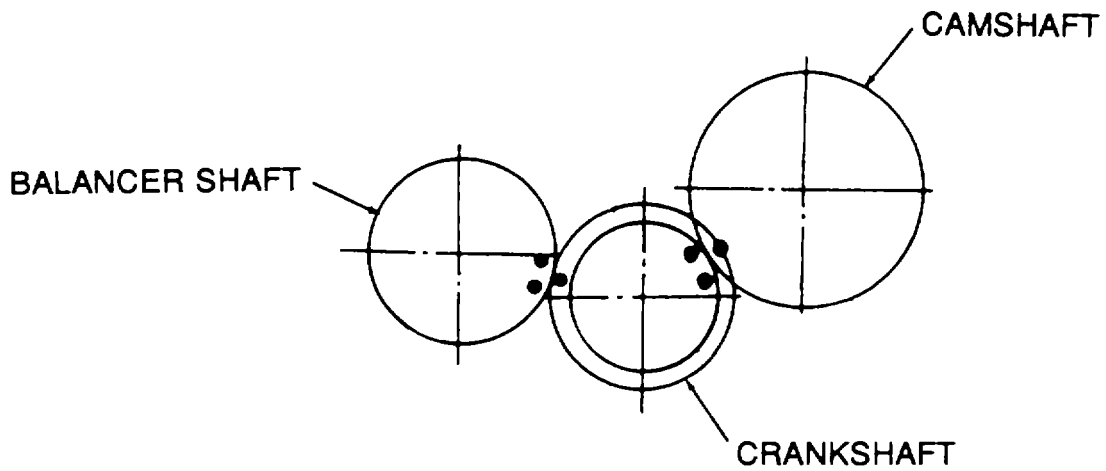

Figure 6-11. Camshaft Timing Marks.

6-10. CRANKSHAFT REPLACEMENT.

This Task Covers:

- a. Removal b. Installation
-

Initial Setup:**Tools Required**

Tool Kit, General Mechanic's (Appendix B, item 1)

Materials Required

Diesel Fuel (Appendix E, Item 6)
Lubricating Oil (Appendix E, Item 8)
Oil Seal, 160110-02220

Equipment Condition

DED pump assembly shut down and cool.
Piston and connecting rod assembly removed (see paragraph 6-6).
Flywheel removed (see paragraph 5-11).

a. Removal. (Refer to Figure 6-12).

- (1) Remove bearing holder (1) and bearing holder nut (2).
- (2) Pull out the crankshaft (3). It may be necessary to carefully tap crankshaft with a rubber mallet.
- (3) Remove oil seal (4) and discard.

b. Installation.

- (1) Lubricate the new oil seal lips and install into crankcase.

CAUTION

Crankshaft must be carefully installed into crankcase to avoid damaging the crankcase oil seal.

- (2) Install the crankshaft (3) into the crankcase.
- (3) Make sure crankshaft has been inserted as far as it will go by tapping on crankshaft with rubber mallet.
- (4) Install the bearing holder (1). Secure with bolt (2).

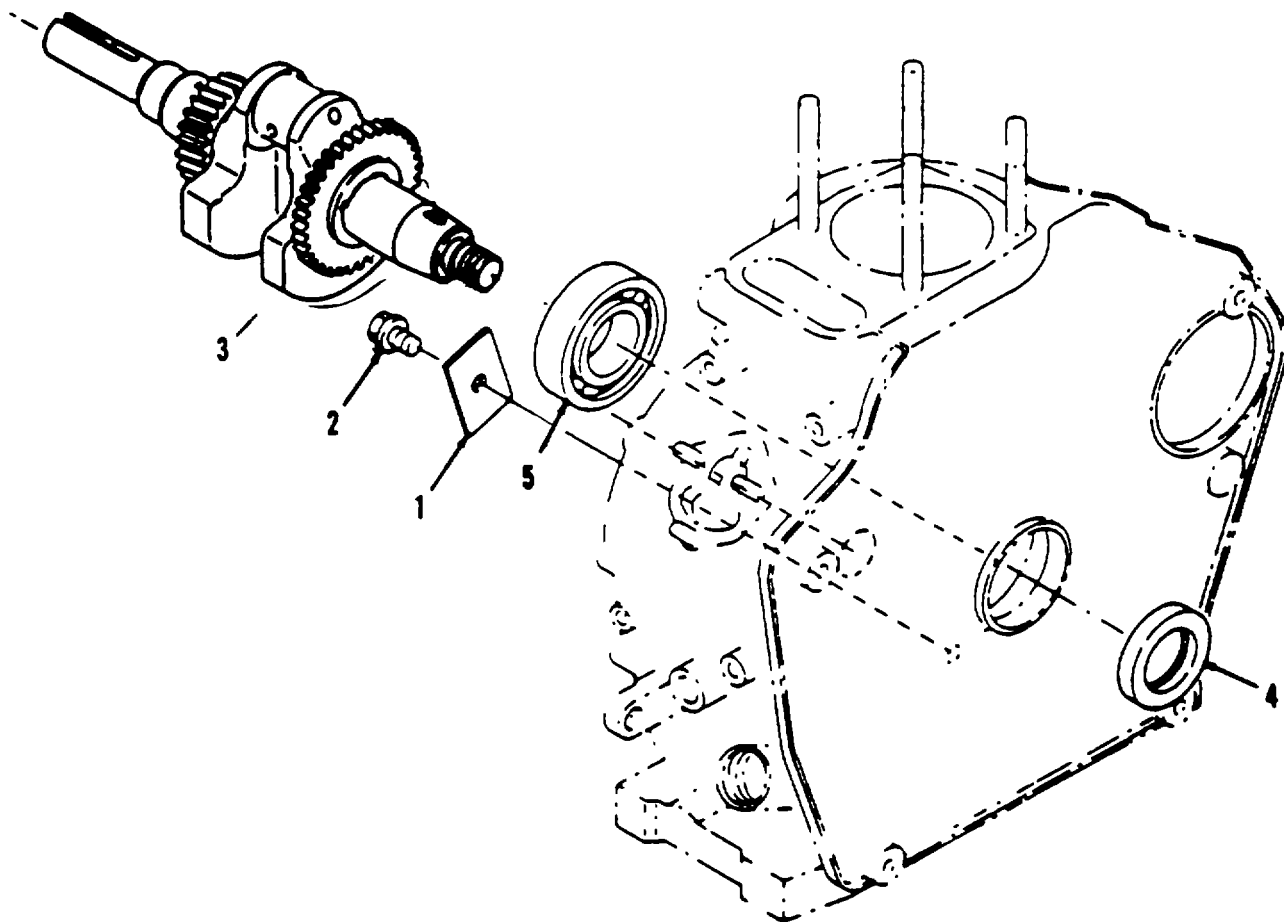

Figure 6-12. Crankshaft Replacement.

APPENDIX A

REFERENCES

A-1. SCOPE. This appendix lists all forms, field manuals, technical manuals, and miscellaneous publications referenced in this manual.

A-2. FORMS.

Report of DiscrepancySF 364
 Equipment Inspection and Maintenance Worksheet DA Form 2404
 Product Quality Deficiency ReportSF 368
 Recommended Changes to Equipment Technical
 Publications DA Form 2028-2
 Recommended Changes to Publications and Blank Forms DA Form 2028

A-3. FIELD MANUALS.

First Aid For Soldiers FM 21-11
 NBC Contamination Avoidance FM 3-3
 NBC Protection FM 34
 NBC Decontamination FM 3-5
 Petroleum Supply Point Equipment and Operation FM 10-69

A-4. TECHNICAL MANUALS.

Administrative Storage of Equipment TM 740-90-1
 Procedures for Destruction of Equipment to Prevent
 Enemy Use (Mobility Equipment Command) TM 750-244-3
 Unit, Direct Support, and General Support Repair Parts and
 Special Tools List for Pumping Assembly, 65 GPM TM10-4320-316-24P

A-5. MISCELLANEOUS PUBLICATIONS AND STANDARDS.

The Army Maintenance Management System DA PAM 738-750
 Abbreviations for Use on Drawings, And Standards, Specifications
 and Technical Documents MIL-STD-12
 Army Medical Department Expendable/Durable Items CTA 8-100
 Expendable Items (Except Medical Class V, Repair Parts
 and Heraldic Items) CTA 50-970
 Lubrication Order LO10-4320-316-12

APPENDIX B

MAINTENANCE ALLOCATION CHART

SECTION I. INTRODUCTION

B-1. The Army Maintenance System MAC.

a. This introduction (section I) provides a general explanation of all maintenance and repair functions authorized at various maintenance categories under the standard Army Maintenance System concept.

b. The Maintenance Allocation Chart (MAC) in section II designates overall authority and responsibility for the performance of maintenance functions on the identified end item or component. The application of the maintenance functions to the end item or component will be consistent with the capacities and capabilities of the designated maintenance levels which are shown on the MAC in column (4) as:

Unit - includes two subcolumns, C (operator/crew) and O (unit Maintenance).

Direct Support - includes and F subcolumn.

General Support - includes an H subcolumn.

Depot - includes a D subcolumn.

c. Section III lists the tools and test equipment (both special tools and common tool sets) required for each maintenance function as referenced from section II.

d. Section [V contains supplemental instructions and explanatory notes for a particular maintenance function.

B-2. Maintenance Functions. Maintenance functions are limited to and defined as follows:

a. **Inspect**. To determine the serviceability of an item by comparing its physical, mechanical, and/or electrical characteristics with established standards through examination (e.g., by sight, sound, or feel).

b. **Test**. To verify serviceability by measuring the mechanical, pneumatic, hydraulic, or electrical characteristics of an item and comparing those characteristics with prescribed standards.

c. **Service**. Operations required periodically to keep an item in proper operating condition, e.g., to clean (includes decontaminate, when required), to preserve, to drain, to paint, or to replenish fuel, lubricants, chemical fluids, or gases.

d. **Adjust**. To maintain or regulate, within prescribed limits, by bringing into proper or exact position, or by setting the operating characteristics to specified parameters.

e. **Align** To adjust specified variable elements of an item to bring about optimum or desired performance.

f. **Calibrate.** To determine and cause corrections to be made or to be adjusted on instruments or test, measuring, and diagnostic equipments used in precision measurement. Consists of comparisons of two instruments, one of which is a certified standard of known accuracy, to detect and adjust any discrepancy in the accuracy of the instrument being compared.

g. **Remove / Install.** To remove and install the same item when required to perform service or other maintenance functions. Install may be the act of emplacing, seating, or fixing into position a spare, repair part, or module (component or assembly) in a manner to allow the proper functioning of an equipment or system.

h. **Replace.** To remove an unserviceable item and install a serviceable counterpart in its place. "Replace" is authorized by the MAC and assigned maintenance level is shown as the 3rd position code of the SMR code.

i. **Repair.** The application of maintenance services¹, including fault location/trouble-shooting², removal/installation, and disassembly/assembly³ procedures, and maintenance actions⁴ to identify troubles and restore serviceability to an item by correcting specific damage, fault, malfunction, or failure in a part, subassembly, module (component or assembly), end item, or system.

j. **Overhaul.** That maintenance effort (service/action) prescribed to restore an item to a completely serviceable/operational condition as required by maintenance standards in appropriate technical publications (i.e., DMWR). Overhaul is normally the highest degree of maintenance performed by the Army. Overhaul does not normally return an item to like new condition.

k. **Rebuild.** Consists of those services/actions necessary for the restoration of unserviceable equipment to a like new condition in accordance with original manufacturing standards. Rebuild is the highest degree of material maintenance applied to Army equipment. The rebuild operation includes the act of returning to zero those age measurements (hours/miles, etc.) considered in classifying Army equipment/components.

¹Services - Inspect, test, service, adjust, align, calibrate, and/or replace.

²Fault location /troubleshooting - The process of investigating and detecting the cause of equipment malfunctioning; the act of isolating a fault within a system or unit under test (UUT).

³Disassembly / assembly - The step-by-step breakdown (taking apart) of a spare/functional group coded item to the level of its least component, that is assigned an SMR code for the level of maintenance under consideration (i. e., identified as maintenance significant).

⁴Actions - Welding, grinding, riveting, straightening, facing, machining, and or resurfacing.

B-3. Explanation of Columns In the MAC, SECTION II.

a. **Column 1, Group Number.** Column 1 lists functional group code numbers, the purpose of which is to identify maintenance significant components, assemblies, subassemblies, and modules with the next higher assembly.

b. **Column 2, Component/Assembly.** Column 2 contains the names of components, assemblies, subassemblies, and modules for which maintenance is authorized.

c. **Column 3, Maintenance Function.** Column 3 lists the functions to be performed on the item listed in Column 2. (For detailed explanation of these functions, see paragraph B-2.)

d. **Column 4, Maintenance Level.** Column 4 specifies each level of maintenance authorized to perform each function listed in Column 3, by indicating work time required (expressed as man hours in whole hours or decimals) in the appropriate subcolumn. This work-time figure represents the active time required to perform that maintenance function at the indicated level of maintenance. If the number or complexity of the tasks within the listed maintenance function vary at different maintenance levels, appropriate work-time figures are to be shown for each level. The work-time figure represents the average time required to restore an item (assembly, subassembly, component, module, end item, or system) to a serviceable condition under typical field operating conditions. This time includes preparation time (including any necessary disassembly/assembly time), troubleshooting/fault location time, and quality assurance/quality control time in addition to the time required to perform the specific tasks identified for the maintenance functions authorized in the maintenance allocation chart. The symbol designations for the various maintenance levels are as follows:

- C Operator or crew maintenance
- O Unit maintenance
- F Direct support maintenance
- L Specialized Repair Activity (SRA)
- H General support maintenance
- D Depot maintenance

e. **Column 5, Tools and Test Equipment reference code.** Column 5 specifies, by code, those common tools sets (not individual tools), common TMDE, and special tools, special TMDE, and support equipment required to perform the designated function. Codes are keyed to tools and test equipment in section III.

f. **Column 6, Remarks.** When applicable, this column contains a letter code, in alphabetical order, which is keyed to the remarks contained in Section IV.

B-4. Explanation of Columns In Tools and Test Equipment Requirements, Section III.

a. **Column 1, Reference Code.** The tool and test equipment reference code correlates with a code used in the MAC, Section II, Column 5.

b. **Column 2, Maintenance Level.** The lowest level of maintenance authorized to use the tool or test equipment.

c. **Column 3, Nomenclature.** Name or identification of the tool or test equipment.

d. **Column 4, National Stock Number.** The National stock number of the tool or test equipment.

e. **Column 5, Tool Number**. The manufacturer's part number, model number, or type number.

B-5. Explanation of Columns In Remarks, Section IV.

a. **Column 1. Reference Code**. The code recorded in column 6, Section II.

b. **Column 2, Remarks**. This column lists information pertinent to the maintenance function being performed as indicated in the MAC, Section II.

**SECTION II. MAINTENANCE ALLOCATION CHART
FOR
PUMP UNIT, CENTRIFUGAL, DIESEL-DRIVEN.**

GROUP NUMBER	COMPONENT ASSEMBLY	MAINTENANCE FUNCTION	MAINTENANCE LEVEL					TOOLS AND EQUIP	REMARKS
			C	O	F	H	D		
00	PUMP UNIT CENTRIFUGAL DIESEL-DRIVEN								
01	ENCLOSURE ASSEMBLY								
0101	Compression Release Handle	Inspect Replace	0.1	0.3				1	
0102	Control Assembly	Inspect Replace	0.1	0.3				1	
0103	Air Intake Hose	Inspect Replace	0.1	0.3				1	
0104	Exhaust Extension	Inspect Replace	0.1	0.3				1	
0105	Access Cover	Inspect Repair Replace	0.1	0.2 0.2				1 1	A
0106	Pump Drain	Inspect Repair Replace	0.1	0.2 0.2				1 1	A
0107	Oil Drain	Inspect Repair Replace	0.1	0.2 0.2				1 1	A
0108	Baffles	Inspect Replace	0.2	0.2				1	
0109	Enclosure Assembly, Inlet Side	Inspect Repair Replace	0.3	0.6 0.4				1, 4 1	A
0110	Enclosure Assembly, Outlet Side	Inspect Repair Replace	0.3	0.6 0.4				1, 4 1	A

**SECTION II. MAINTENANCE ALLOCATION CHART
FOR
PUMP UNIT, CENTRIFUGAL, DIESEL-DRIVEN.**

GROUP NUMBER	COMPONENT ASSEMBLY	MAINTENANCE FUNCTION	MAINTENANCE LEVEL					TOOLS AND EQUIP	REMARKS
			C	O	F	H	D		
0305	Pipe Fuel Gauge	Inspect Replace	0.1	0.3				1	
0306	Fuel Lines	Inspect Replace	0.1	0.5				1	
0307	Air Cleaner	Inspect Repair Replace	0.1	0.4 0.5				1 1	A
030701	Filter Element	Inspect Service Replace	0.1 0.2	0.2					
030702	Air Intake Pipe	Inspect Repair Replace		0.1 0.2 0.3				1 1	A
0308	Exhaust Silencer	Inspect Repair Replace	0.1	0.3 0.4				1 1	A
0309	Recoil Starter	Inspect Repair Replace	0.2	0.5 0.4				1, 2 1, 2	A
0310	Cooling Fan Case	Inspect Replace		0.1 0.4				1, 2	
0311	Fuel Injector Valve Assembly	Test Replace		0.5 0.6				1, 3 1, 3, 5	B
0312	Fuel Injector Pump	Inspect Replace		0.1 0.5				1, 3	
0313	Lube Oil Strainer	Inspect Service Repair Replace		0.1 0.2 0.2 0.2					A

**SECTION II. MAINTENANCE ALLOCATION CHART
FOR
PUMP UNIT, CENTRIFUGAL, DIESEL-DRIVEN.**

GROUP NUMBER	COMPONENT ASSEMBLY	MAINTENANCE FUNCTION	MAINTENANCE LEVEL					TOOLS AND EQUIP	REMARKS
			C	O	F	H	D		
0305	Pipe Fuel Gauge	Inspect Replace	0.1	0.3				1	
0306	Fuel Lines	Inspect Replace	0.1	0.5				1	
0307	Air Cleaner	Inspect Repair Replace	0.1	0.4 0.5				1 1	A
030701	Filter Element	Inspect Service Replace	0.1 0.2	0.2					
030702	Air Intake Pipe	Inspect Repair Replace	0.1 0.2 0.3					1 1	A
0308	Exhaust Silencer	Inspect Repair Replace	0.1	0.3 0.4				1 1	A
0309	Recoil Starter	Inspect Repair Replace	0.2	0.5 0.4				1, 2 1, 2	A
0310	Cooling Fan Case	Inspect Replace	0.1 0.4					1, 2	
0311	Fuel Injector Valve Assembly	Test Replace		0.5 0.6				1, 3 1, 3, 5	B
0312	Fuel Injector Pump	Inspect Replace	0.1 0.5					1, 3	
0313	Lube Oil Strainer	Inspect Service Repair Replace	0.1 0.2 0.2 0.2						A

**SECTION II. MAINTENANCE ALLOCATION CHART
FOR
PUMP UNIT, CENTRIFUGAL, DIESEL-DRIVEN.**

GROUP NUMBER	COMPONENT ASSEMBLY	MAINTENANCE FUNCTION	MAINTENANCE LEVEL					TOOLS AND EQUIP	REMARKS
			C	O	F	H	D		
0314	Oil Cap/Gauge	Inspect Repair Replace	0.1	0.2 0.1					A
0315	Regulator Bracket Assembly	Inspect Repair Replace Adjust	0.3	0.2	0.4 0.4 0.2			1 1	A
0316	Cylinder Head Assembly Adjust	Inspect Repair Replace			0.2 1.5 1.0 1.0			1, 3 1, 3 1, 3 1, 3	
0317	Flywheel	Inspect Replace			0.1 0.4			1 1	
0318	Crankcase Assembly	Inspect Repair Replace				0.2 0.3 0.3		1, 3 1, 3	A
0319	Piston and Connecting Rod Assembly	Inspect Repair Replace				0.2 1.0 1.0		1, 3 1, 3 1, 3	A
0320	Governor Assembly	Inspect Repair Replace				0.2 0.3 0.3		1, 3 1, 3 1, 3	A
0321	Lube Oil Pump	Inspect Repair Replace				0.2 0.3 0.3		1 1	A
0322	Balancer Shaft Assembly	Inspect Replace				0.2 0.4		1, 3 1, 3	
0323	Camshaft Assembly	Inspect Replace				0.3 0.5		1, 3 1, 3	
0324	Crankshaft Assembly	Inspect Replace				0.3 0.5		1, 3 1, 3	
0325	Cylinder Block	Replace				0.3		1, 3	

SECTION III. TOOL AND TEST EQUIPMENT REQUIREMENTS

(1) REFERENCE CODE	(2) MAINTENANCE CATEGORY	(3) NOMENCLATURE	(4) NATIONAL/AUTO STOCK NUMBER	(5) TOOL NUMBER
1	O	Standard tools and test equipment contained in the following kit are adequate to perform the maintenance functions listed in Section II. Tool Kit, General Mechanic's	5180-00-177-7033	SC 5180-90 -CL-N26 (19099)
2	O	Shop Equipment, Automotive Maintenance Repair; Unit Maintenance, Common No. 1	4910-00-754-0654	SC 4910-95- CL-A74- (19099)
3	F	Shop Equipment, Automotive Maintenance	4940-00-914-2576	SC 4940-95 -CL-B05
4	H	Shop Equipment, Automotive Maintenance and Repair; Field Maintenance, Supplement 2	4910-00-754-0707	SC 4910-95 -A63
5	O	Riveter, Blind, Hand	5120-00-017-2849	
6	F	SPECIAL TOOLS Bolt, Hex Head, 3/8-16 x 4.00 in. lg.		

SECTION IV. REMARKS.

REFERENCE CODE	REMARKS
A	Repair is limited to the replacement of components found defective during inspection.
B	Use bolt for removal of fuel injector valve nozzle gasket.
C	To replace cylinder block, remove all components attached to old cylinder block and attach these components to new cylinder block.

APPENDIX C

COMPONENTS OF END ITEM AND BASIC ISSUE ITEMS LISTS

SECTION I. INTRODUCTION

C-1. SCOPE.

This appendix lists components of end item and basic issue items for the DED Pump Assembly to help you inventory items required for safe and efficient operation.

C-2. GENERAL.

The Components of End Item and Basic Issue Items Lists are divided into the following sections:

a. Section II. Components of End Item. This listing is for informational purposes only, and is not authority to requisition replacements. These items are part of the end item, but are removed and separately packaged for transportation or shipment. As part of the end item, these items must be with the end item whenever it is issued or transferred between property accounts.

b. Section III Basic Issue Items (BII). These essential items required to place the DED Pump Assembly in operation, to operate it, and to do emergency repairs. Although shipped separately packaged, BII must be with the system during operation and whenever it is transferred between property accounts. Listing these items is your authority to request/requisition them for replacement, based on authorization of the end item by TOE/MTOE. Illustrations are furnished to help you find and identify the items.

C-3. EXPLANATION OF COLUMNS.

The following provides an explanation of columns found in the tabular listings:

a. Column (1) Illustration Number (Illus. Number). This column indicates the number of the illustration in which the item is shown.

b. Column (2) National Stock Number. Indicates the National stock number of the item to be used for requisitioning purposes.

c. Column (3) Description. Identifies the Federal item name (in all capital letters) followed by a minimum description when needed. The last line below the description is the CAGEC (Commercial and Government Entity Code) (in parentheses) and the part number.

d. Column (4) Unit of Issue (U/I). Indicates how the item is issued for the National Stock Number shown in column two.

e. Column (5) - Quantity required (Qty Rqr). Indicates the quantity required.

SECTION II. COMPONENTS OF END ITEM

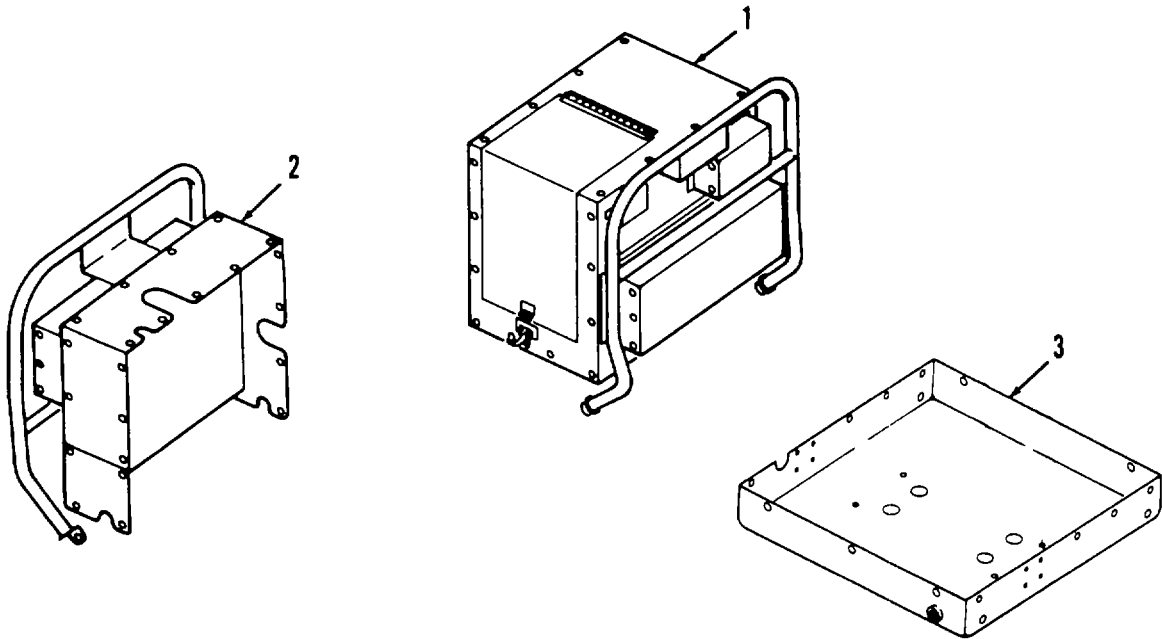

(1) ILLUS NUMBER	(2) NATIONAL STOCK NUMBER	(3) DESCRIPTION CAGEC and Part Number	(4) Usable On Code U/M	(5) QTY Rqr
1		ENCLOSURE ASSEMBLY, INLET SIDE (97403) 13229E9681	EA	1
2		ENCLOSURE ASSEMBLY, OUTLET SIDE (97403) 13229E9680	EA	1
3		FRAME, BOTTOM PAN (97403) 13229E9683	EA	1

SECTION II. COMPONENTS OF END ITEM

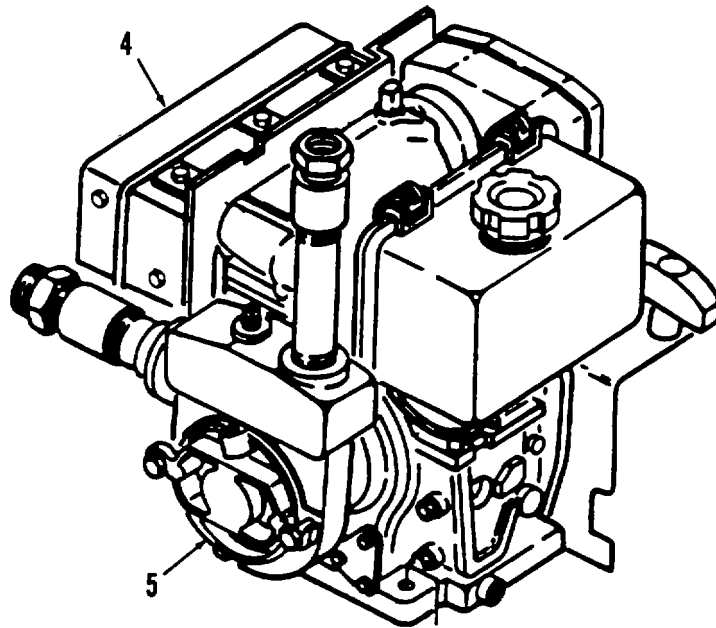

(1) ILLUS NUMBER	(2) NATIONAL STOCK NUMBER	(3) DESCRIPTION CAGEC and Part Number	(4) Usable On Code	(5) QTY Rqr
4		DIESEL ENGINE 3.8 HORSEPOWER (0AK42) L40E-D-SP1	EA	1
5		PUMP, 65 GPM CENTRIFUGAL SELF-PRIMING (97403) 13228E5174	EA	1

SECTION II. BASIC ISSUE ITEMS

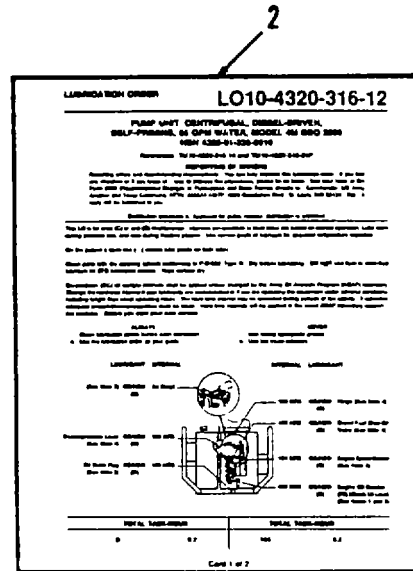
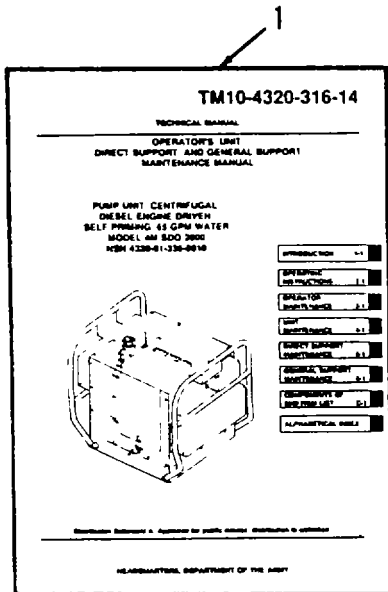

(1) ILLUS NUMBER	(2) NATIONAL STOCK NUMBER	(3) DESCRIPTION CAGEC and Part Number Usable On Code	(4) U/M	(5) QTY Rqr
1	TM10-4320-316-14	Technical Manual: Operator's, Unit, Direct Support, and General Support for Pump Unit, Centrifugal, Diesel Engine Driven, Self-Priming, 65 GPM Water, Class 3	EA	1
2		Lubrication Order L010-4320-316-12	EA	1

**APPENDIX D
ADDITIONAL AUTHORIZATION LIST**

SECTION I. INTRODUCTION

D-1. SCOPE.

This appendix lists additional items you are authorized for the support of the DED Pump Assembly.

D-2. GENERAL.

This list identifies items that do not have to accompany the DED Pump Assembly and that do not have to be turned in with it. These items are all authorized to you by CTA, MTOE, TDA, or JTA

D-3. EXPLANATION OF LISTING.

National stock numbers, descriptions, and quantities are provided to help you identify and request the additional items you require to support this equipment. The items are listed in alphabetical sequence by item name. If the item you require differs between the serial numbers of the same model, effective serial numbers are shown in the last line of the description. If the item required differs for different models of this equipment, the model number is shown under the "Usable On" heading in the description column.

SECTION II. ADDITIONAL AUTHORIZATION LIST

(1) NATIONAL STOCK NUMBER	(2) DESCRIPTION CAGE and Part Number	(3) Usable On Code U/M	(4) QTY AUTH
	<p>NO ADDITIONAL AUTHORIZATION ITEMS ARE AUTHORIZED FOR THE DED PUMP ASSEMBLY.</p>		

APPENDIX E
EXPENDABLE / DURABLE SUPPLIES AND MATERIALS LIST

SECTION I. INTRODUCTION

E-1. SCOPE.

This appendix lists expendable supplies and materials you will need to operate and maintain the DED Pump Assembly. This listing is for information only and is not authority to requisition the listed items. These items are authorized to you by CTA 50-970, Expendable Items (except medical, class V, repair parts, and heraldic items) or CTA 8-100, Army Medical Department Expendable/Durable Items.

E-2. EXPLANATION OF COLUMNS.

a. Column (1) - Item number. This number is assigned to the entry in the listing and is referenced in the narrative instructions to identify the material (e.g., "Use cleaning compound, item 5, Appendix E").

b. Column (2) - Level. This column identifies the lowest level of maintenance that requires the listed item.

C - Operator/Crew
O - Unit Maintenance
F - Direct Support Maintenance
H - General Support Maintenance

c. Column (3) - National Stock Number. This is the National stock number assigned to the item which you can use to requisition it.

d. Column (4) - Item Name, Description, Commercial and Government Entity Code (CAGEC), and Part Number. This provides the other information you need to identify the item.

e. Column (5) - Unit of Measure (U/M). This code shows the physical measurement or count of an item, such as gallon, dozen, gross, etc.

SECTION II EXPENDABLE/DURABLE SUPPLIES AND MATERIALS LIST

(1) ITEM NO.	(2) LEVEL	(3) NATIONAL STOCK NUMBER	(4) ITEM, NAME, DESCRIPTION CAGEC, PART NUMBER	(5) U/M
1	O	7920-00-205-1711	Cloth, Lint-Free	ea
2	O	8020-00-207-6658	Brush, Medium, Oval	ea
3	O	6850-00-274-5421	Dry Cleaning Solvent, (81348) P-D-680, Type III	gl
4	O		Silicone Compound (81349) MILS-8660	qt
5	F		Abrasive Cloth, Crocus, (81348) P-C-458	ea
6	C		Fuel, Diesel, (81348) W-F-800	gl
7	O		Oil, Lubricating, Preservative, (81349) MIL-L-21260	qt
8	O	9150-00-186-6681	Oil, Lubricating, Internal Combustion Engine, (81349) MIL-L-2104	qt
9	H		Plastigage, (70220) PG-1	ea
10	O	7930-00-985-6911	Detergent, General Purpose	gl
11	O	8030-00-889-3534	Tape, Anti-seize (81349) MIL-T-27730, Size 1	rl

**APPENDIX F
ILLUSTRATED LIST OF MANUFACTURED ITEMS**

SECTION I. INTRODUCTION

- a.** This appendix includes complete instructions for making items authorized to be manufactured or fabricated at unit maintenance level (or aviation maintenance level, if applicable).
- b.** A part number index in alphabetical order is provided for cross-referencing the part number of the item to be manufactured to the figure which covers fabrication criteria.
- c.** All bulk materials needed for manufacture of an item are listed by the part number or specification in a tabular list on the illustration

PART NUMBER INDEX

Part Number to Be Manufactured	Part Name	Manufacturing Figure
13229E9679-12	Plastic Foam	F-1
13229E9679-13	Plastic Foam	F-1
13229E9679-14	Plastic Foam	F-1
13229E9679-15	Plastic Foam	F-1
13229E9679-16	Plastic Foam	F-7
13229E9679-17	Plastic Foam	F-1
13229E9679-18	Plastic Foam	F-3
13229E9679-20	Plastic Foam	F-2
13229E9679-21	Plastic Foam	F-2
13229E9679-22	Plastic Foam	F-2
13229E9679-23	Plastic Foam	F-2
13229E9679-24	Plastic Foam	F-2
13229E9679-25	Plastic Foam	F-2
13229E9680-7	Plastic Foam	F-1
13229E9680-8	Plastic Foam	F-8
13229E9680-9	Plastic Foam	F-5
13229E9680-10	Plastic Foam	F-2
13229E9680-11	Plastic Foam	F-2
13229E9680-12	Plastic Foam	F-2
13229E9680-19	Plastic Foam	F-1
13229E9684-3	Plastic Foam	F-6
13229E9684-4	Plastic Foam	F-1
13229E9684-5	Plastic Foam	F-1
13229E9684-6	Plastic Foam	F-4
13229E9689-2	Plastic Foam	F-1

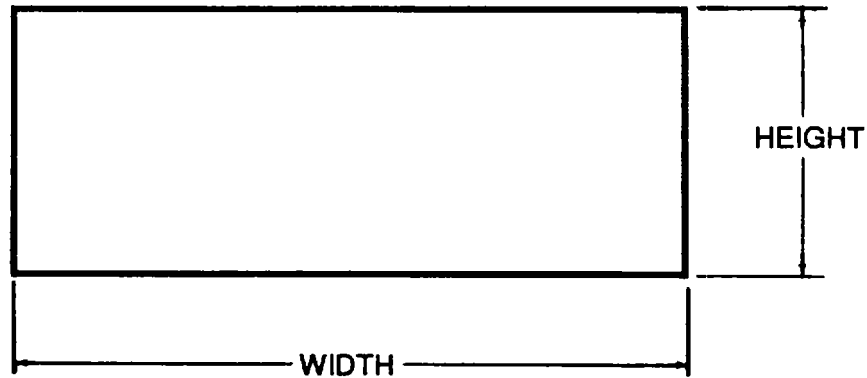

Part Number	Width	Height
13229E9679-12	5.38	2.75
13229E9679-13	8.94	12.06
13229E9679-14	8.94	10.13
13229E9679-15	9.75	11.50
13229E9679-17	11.50	14.75
13229E9680-7	16.00	11.63
13229E9680-19	5.56	9.50
13229E9684-4	3.13	8.25
13229E9684-5	3.13	14.50
13229E9689-2	4.69	5.19

PART NO: See Tabulation

MATERIAL: Foam, open cell, flexible polyether urethane, adhesive backed, 2.00 thick. Bulk material part number (97403) 13229E9692-3.

PROCEDURE: Cut foam to length and width as indicated in table.

Figure F-1.

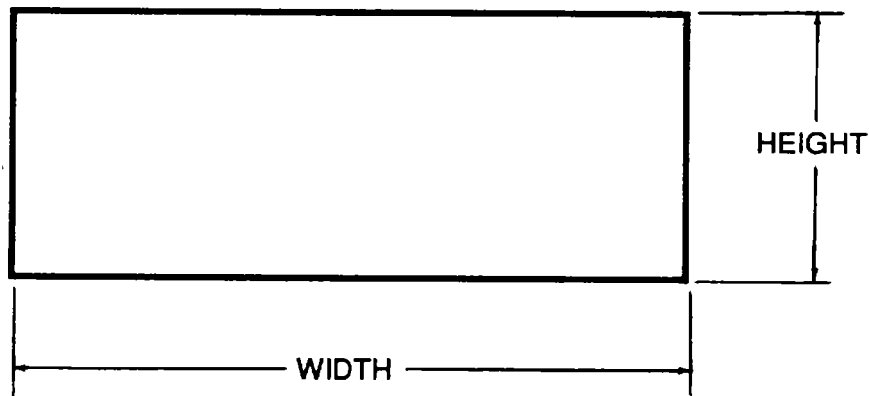

Part Number	Width	Height
13229E9679-20	16.81	6.00
13229E9679-21	18.25	3.38
13229E9679-22	4.94	3.00
13229E9679-23	6.38	2.50
13229E9679-24	3.00	2.50
13229E9679-25	3.38	6.00
13229E9680-10	3.38	6.00
13229E9680-11	16.81	6.00
13229E9680-12	18.25	3.38

PART NO: See Tabulation

MATERIAL: Foam, open cell, flexible polyether urethane, adhesive backed, 0.75 inches thick. Bulk material part number (97403) 13229E9692-1.

PROCEDURE: Cut foam to length and width as indicated in table.

Figure F-2.

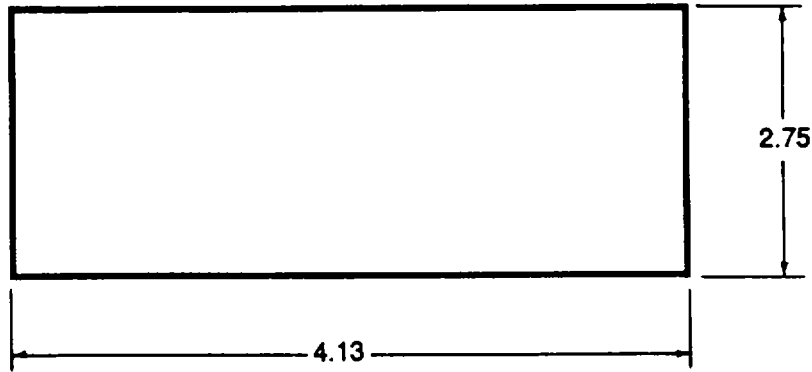

PART NO: 13229E9679-18

MATERIAL: Foam, open cell, flexible polyether urethane, adhesive backed, 1.00 inches thick. Bulk material part number (97403) 13229E9692-2.

PROCEDURE: Cut foam to length and width as indicated in table.

Figure F-3.

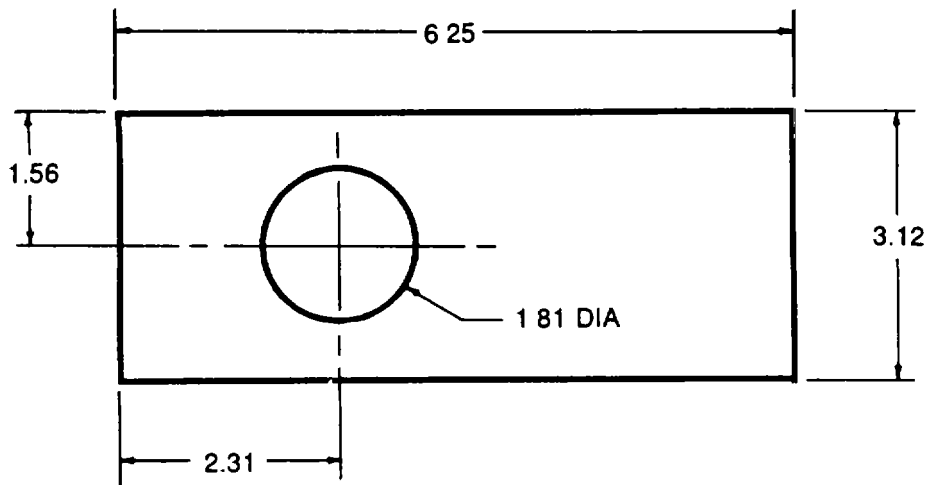

PART NO: 13229E9684-6

MATERIAL: Foam, open cell, flexible polyether urethane, adhesive backed, 1.00 inches thick. Bulk material part number (97403) 13229E9692-2.

PROCEDURE: Cut foam to length and width as indicated in table.

Figure F-4.

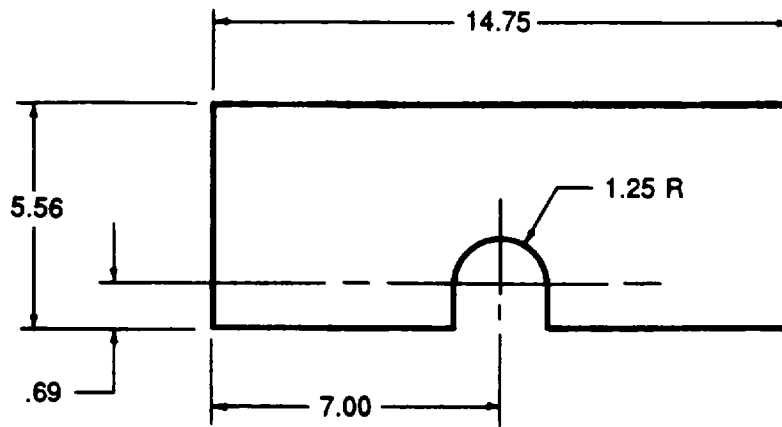

PART NO: 13229E9680-9

MATERIAL: Foam, open cell, flexible polyether urethane, adhesive backed, 2.00 inches thick. Bulk material part number (97403) 13229E9692-3.

PROCEDURE: Cut foam to length and width as indicated in table.

Figure F-5.

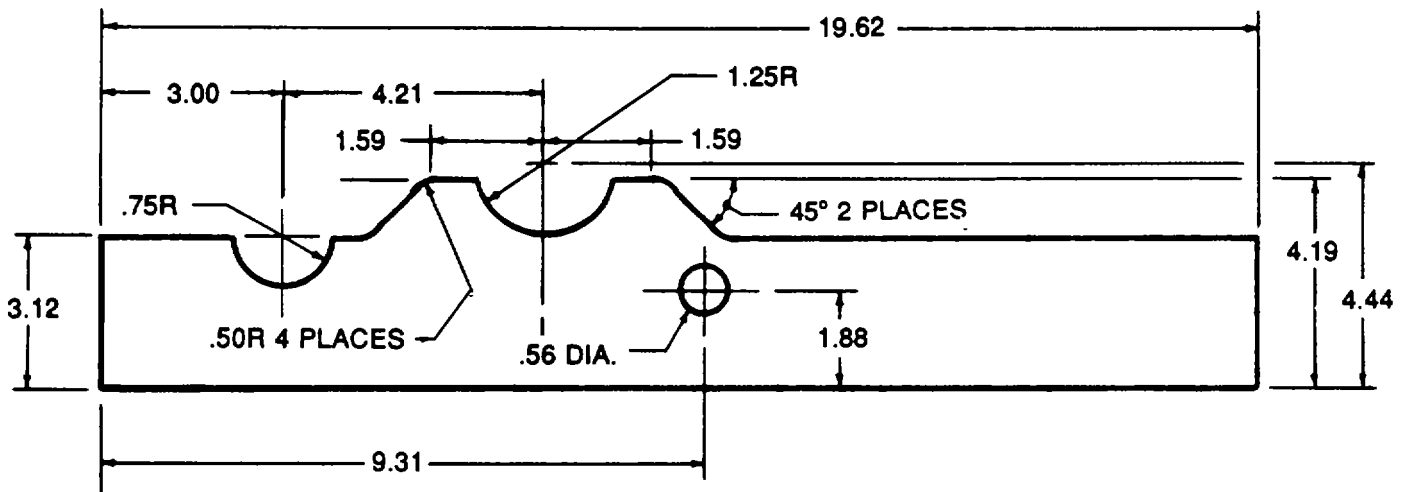

PART NO: 13229E9684-3

MATERIAL: Foam, open cell, flexible polyether urethane, adhesive backed, 2.00 inches thick. Bulk material part number (97403) 13229E9692-3.

PROCEDURE: Cut foam to length and width as indicated in table.

Figure F-6.

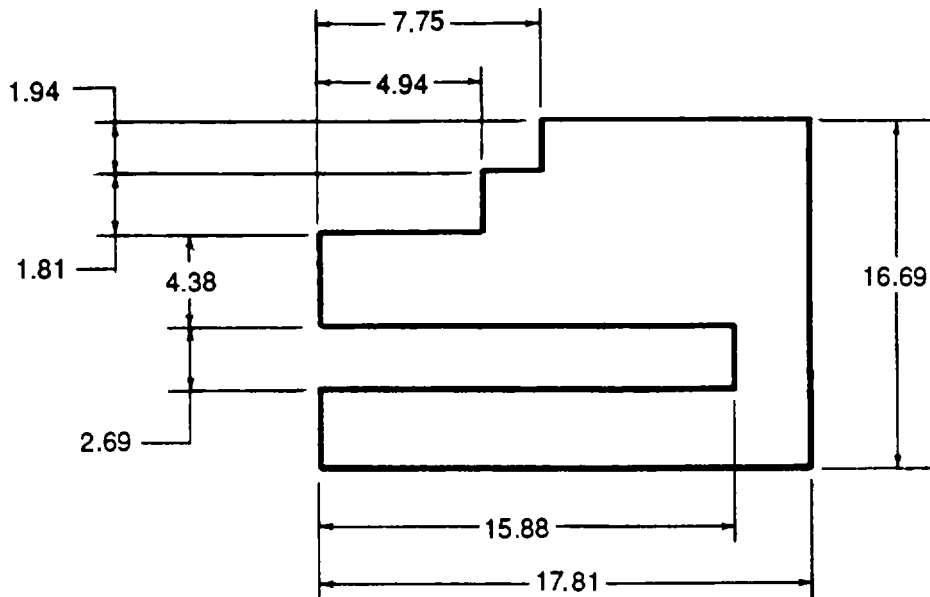

PART NO: 13229E9679-16

MATERIAL: Foam, open cell, flexible polyether urethane, adhesive backed, 2.00 inches thick. Bulk material part number (97403) 13229E9692-3.

PROCEDURE: Cut foam to length and width as indicated in table.

Figure F-7.

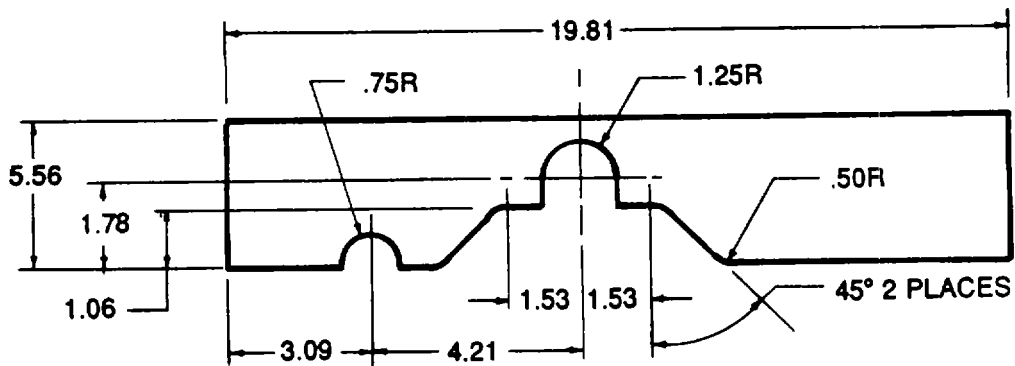

PART NO: 13229E9680-8

MATERIAL: Foam, open cell, flexible polyether urethane, adhesive backed, 2.00 inches thick. Bulk material part number (97403) 13229E9692-3.

PROCEDURE: Cut foam to length and width as indicated in table.

Figure F-8.

APPENDIX G
TORQUE LIMITS

G-1. GENERAL. This appendix provides general torque limits for fasteners. Special torque values are indicated in the maintenance procedures for applicable components. The general torque values given in this appendix shall be used when specific torque values are not indicated in the maintenance procedures.

G-2. TORQUE LIMITS. Torque limits are listed in Table G-1 for fasteners. Dry fasteners are defined as fasteners on which no lubricants are applied to the threads. Wet fasteners are defined as fasteners on which graphite or molydisulphide greases or other extreme pressure lubricants are applied to the threads. Table G-2 lists the minimum breakaway torque values for locknuts.

Table G-1. General Torque Requirements for Dry Fasteners.*

Bolt/Screw Size	Torque Requirement in lb ft (N•m)			
	SAE Grade 1 or 2	SAE Grade 5	SAE Grade 6 or 7	SAE Grade 8
1/4-20 UNC 1/4-28 UNF	5 (7) 6 (8)	8 (11) 10 (14)	10 (14) 12 (16)	12 (16) 14 (19)
5/16 18 UNC 5/16-24 UNF	11 (15) 13 (18)	17 (23) 19 (26)	19 (26) 23 (31)	24 (33) 27 (37)
3/8 16 UNC 3/8-24 UNF	18 (24) 20 (27)	31 (42) 35 (47)	34 (46) 42 (57)	44 (60) 49 (66)
7/16-14 UNC 7/16-20 UNF	28 (38) 30 (41)	49 (66) 55 (75)	55 (75) 67 (91)	70 (95) 78 (106)
1/2-13 UNC 1/2-20 UNF	39 (53) 41 (56)	75 (102) 85 (115)	85 (115) 102 (138)	105 (142) 120 (163)
9/16-12 UNC 9/16-18 UNF	51 (69) 55 (75)	110 (149) 120 (163)	120 (163) 145 (197)	155 (210) 170 (231)
5/8-11 UNC 5/8-18 UNF	63 (85) 95 (129)	150 (203) 170 (231)	167 (226) 205 (278)	210 (285) 240 (325)
3/4-10 UNC 3/4-16 UNF	105 (142) 115 (156)	270 (366) 295 (400)	280 (380) 357 (484)	375 (509) 420 (570)
7/8-9 UNC 7/8-14 UNF	160 (217) 175 (237)	395 (536) 435 (590)	440 (597) 555 (753)	605 (820) 675 (915)

Table G-1. General Torque Requirements for Dry Fasteners.* - Continued.

Bolt/Screw Size	Torque Requirement in lb ft (N•m)			
	SAE Grade 1 or 2	SAE Grade 5	SAE Grade 6 or 7	SAE Grade 8
1-8 UNC 1-14 UNF	235 (319) 250 (339)	590 (800) 660 (895)	660 (895) 825 (1119)	910 (1234) 990 (1342)
1-1/8-7 UNC 1-1/8-12 UNF	350 (475) 400 (542)	800 (1085) 880 (1193)	1000 (1356) 1050 (1424)	1280 (1736) 1440 (1953)
1-1/4-7 UNC 1-1/4-12 UNF	500 (678) 550 (746)	1080 (1464) 1125 (1526)	1325 (1797) 1325 (1797)	1820 (2468) 1820 (2712)
1-3/8-6 UNC 1-3/8-12 UNF	660 (895) 740 (1003)	1460 (1980) 1680 (2278)	1800 (2441) 1960 (2658)	2380 (3227) 2720 (3688)
1-1/2-6 UNC 1-1/2-12 UNF	870 (1180) 980 (1329)	1940 (2631) 2200 (2983)	2913 (3950) 3000 (4068)	3160 (4285) 3560 (4827)

* Torque given is for clean, dry threads Reduce by 10% when engine oil is used as lubricant

Table G-2. Locknut Breakaway Torque Values.

NOTE

To determine breakaway torque, thread lock nut onto screw or bolt until at least two threads stick out. Locknut shall not make contact with a mating part. Stop the locknut. Torque necessary to begin turning locknut again is the breakaway torque. Do not reuse locknuts that do not meet minimum breakaway torque.

Thread Size	Minimum Breakaway Torque	
	lb-in	(N•m)
10-32	2.0	(0.23)
1/4-28	3.5	(0.40)
5/16-24	6.5	(0.73)
3/8-24	9.5	(1.07)
7/16-20	14.0	(1.58)
1/2-20	18.0	(2.03)
9/16-18	24.0	(2.71)
5/8-18	32.0	(3.62)
3/4-16	50.0	(5.65)
7/8-14	70.0	(7.91)
1-12	90.0	(10.17)
1-1/8-12	117.0	(13.22)

ALPHABETICAL INDEX

	Paragraph	Page
A		
Abbreviations, List of	1-8	1-2
Access Cover Repair and Replacement	4-18	4-28
Additional Authorization List	D-1	D-1
Adjustments, Initial, Daily Checks, and Self tests	2-8	2-15
Air Cleaner Filter Element, Engine, Servicing	3-7	3-6
Air Cleaner, Filter Element, and Air Intake Pipe Repair and Replacement	4-31	4-70
Air Intake Hose Replacement	4-16	4-24
Assembly and Preparation for Use	2-7	2-12
B		
Baffles Replacement	4-21	4-34
Balancer Shaft Assembly Replacement	6-8	6-16
Basic Issue Items	C-1	C-1
Bottom Pan Frame Repair and Replacement	4-25	4-48
C		
Camshaft Assembly Replacement	6-9	6-18
Common Tools and Equipment, General Support	6-1	6-1
Common Tools and Equipment, Direct Support	5-1	5-1
Common Tools and Equipment, Unit	4-1	4-1
Components of End Item List	C-1	C-1
Compression Release Handle Replacement	4-14	4-20
Control Assembly Replacement.....	4-15	4-22
Controls and Indicators, Operator	2-2	2-2
Corrosion and Prevention Control	1-3	1-1
Crankcase Assembly Repair and Replacement	6-5	6-2
Crankshaft Replacement	6-10	6-20
Cylinder Head Assembly Repair and Replacement	5-10	5-14
D		
Decals and Instruction Plates	2-11	2-18
Destruction of Army Materiel to Prevent Enemy Use	1-4	1-1
E		
Emergency Procedures	2-13	2-22
Enclosure Assembly, Outlet Side Repair and Replacement	4-23	4-42
Enclosure Assembly, Inlet Side Repair and Replacement	4-22	4-38
Equipment Data	1-11	1-4
Equipment Characteristics, Capabilities, and Features	1-9	1-2
Exhaust Silencer Repair and Replacement	4-32	4-72
Exhaust Extension Replacement	4-17	4-26
Expendable / Durables Supplies and Materials List	E-1	E-1

ALPHABETICAL INDEX

	Paragraph	Page
F		
Flywheel Replacement	5-11	5-22
Fuel Tank Assembly Repair and Replacement	4-27	4-60
Fuel Filter, Inlet Replacement	4-28	4-64
Fuel Injector Pump Replacement	4-34	4-78
Fuel Injector Valve Assembly Replacement	5-8	5-6
Fuel Inlet Filter, Servicing	3-6	3-5
Fuel Cock and Fuel Filter, Outlet Replacement	4-29	4-66
Fuel Lines Replacement.....	4-30	4-68
G		
Governor Assembly Repair and Replacement	6-7	6-12
I		
Ident Plates Replacement	4-12	4-16
Illustrated List of Manufactured items	F-1	F-1
Installation Instructions	4-6	4-3
L		
Lube Oil Strainer Repair and Replacement	4-35	4-80
Lube Oil Pump Repair and Replacement	6-7	6-12
Lubrication	4-7	4-4
M		
Maintenance Allocation Chart.....	B-1	B-1
Maintenance Forms and Procedures	1-2	1-1
Major Components, Location and Description	1-10	1-2
Mounting Plate Repair and Replacement	5-7	5-4
Movement, Preparation for	2-10	2-18
N		
Nomenclature Cross-Reference.....	1-7	1-2
Nuclear, Biological, and Chemical (NBC) Decontamination Procedures	2-14	2-22
O		
Oil Drain Repair and Replacement	4-20	4-32
Oil Cap/Gauge Repair and Replacement	4-36	4-82
Operating Procedures	2-9	2-15
Operation Under Unusual Weather	2-12	2-20

ALPHABETICAL INDEX

	Paragraph	Page
P		
Piston and Connecting Rod Assembly Repair and Replacement	6-6	6-6
Preventive Maintenance Checks and Services, Operator	2-4	2-4
Preventive Maintenance Checks and Services, Unit.....	4-9	4-5
Pump Assembly, Repair and Replacement.....	4-26	4-54
Pump Inlet/Outlet Piping Repair and Replacement	4-24	4-46
Pump Drain Repair and Replacement	4-19	4-30
R		
Recoil Starter and Cooling Fan Case Repair and Replacement	4-33	4-74
References	A-1	A-1
Regulator Bracket Assembly Repair, Adjustment, and Replacement	5-9	5-10
Reporting Equipment Improvement Recommendations (EIR's)	1-6	1-1
Roll-Over Frame Replacement	4-13	4-18
S		
Service Upon Receipt	4-5	4-2
Site and Shelter Requirements	4-4	4-1
Special Tools, TMDE, and Support Equipment	4-2	4-1
Storage or Shipment, Preparation for	4-37	4-84
Storage of Equipment, Administrative	4-38	4-84
Storage or Shipment, Preparation for	1-5	1-1
Suction Flange Assembly Repair and Replacement	4-24	4-46
T		
Theory of Operations	1-12	1-5
Torque Limits	G-1	G-1
Troubleshooting, Operator.....	3-4	3-1
Troubleshooting, Unit	4-10	4-9
Troubleshooting, Direct Support	5-5	5-1

TM 10-4320-316-14

By Order of the Secretary of the Army.

GORDON R. SULLIVAN
General, United States Army
Chief of Staff

Official



MILTON H. HAMILTON
Administrative Assistant to the
Secretary of the Army
06364

DISTRIBUTION:

To be distributed in accordance with DA Form 12-25-E, block no. 5283,
requirements for TM 10-4320-316-14.

RECOMMENDED CHANGES TO EQUIPMENT TECHNICAL PUBLICATIONS



THEN...JOT DOWN THE
DOPE ABOUT IT ON THIS FORM.
CAREFULLY TEAR IT OUT, FOLD IT
AND DROP IT IN THE MAIL.

SOMETHING WRONG WITH PUBLICATION

FROM: (PRINT YOUR UNIT'S COMPLETE ADDRESS)

DATE SENT

PUBLICATION NUMBER

PUBLICATION DATE

PUBLICATION TITLE

BE EXACT PIN-POINT WHERE IT IS

PAGE
NO.

PARA-
GRAPH

FIGURE
NO.

TABLE
NO.

IN THIS SPACE, TELL WHAT IS WRONG
AND WHAT SHOULD BE DONE ABOUT IT.

PRINTED NAME, GRADE OR TITLE AND TELEPHONE NUMBER

SIGN HERE

The Metric System and Equivalents

Linear Measure

1 centimeter = 10 millimeters = .39 inch
 1 decimeter = 10 centimeters = 3.94 inches
 1 meter = 10 decimeters = 39.37 inches
 1 dekameter = 10 meters = 32.8 feet
 1 hectometer = 10 dekameters = 328.08 feet
 1 kilometer = 10 hectometers = 3,280.8 feet

Weights

1 centigram = 10 milligrams = .15 grain
 1 decigram = 10 centigrams = 1.54 grains
 1 gram = 10 decigrams = .035 ounce
 1 decagram = 10 grams = .35 ounce
 acres
 1 hectogram = 10 decagrams = 3.52 ounces
 1 kilogram = 10 hectograms = 2.2 pounds
 1 quintal = 100 kilograms = 220.46 pounds
 1 metric ton = 10 quintals = 1.1 short tons

Liquid Measure

1 centiliter = 10 milliliters = .34 fl. ounce
 1 deciliter = 10 centiliters = 3.38 fl. ounces
 1 liter = 10 deciliters = 33.81 fl. ounces
 1 dekaliter = 10 liters = 2.64 gallons
 1 hectoliter = 10 dekaliters = 26.42 gallons
 1 kiloliter = 10 hectoliters = 264.18 gallons

Square Measure

1 sq. centimeter = 100 sq. millimeters = .155 sq. inch
 1 sq. decimeter = 100 sq. centimeters = 15.5 sq. inches
 1 sq. meter (centare) = 100 sq. decimeters = 10.76 sq. feet
 1 sq. dekameter (are) = 100 sq. meters = 1,076.4 sq. feet
 1 sq. hectometer (hectare) = 100 sq. dekameters = 2.47
 1 sq. kilometer = 100 sq. hectometers = .386 sq. mile

Cubic Measure

1 cu. centimeter = 1000 cu. millimeters = .06 cu. inch
 1 cu. decimeter = 1000 cu. centimeters = 61.02 cu. inches
 1 cu. meter = 1000 cu. decimeters = 35.31 cu. feet

Approximate Conversion Factors

<i>To change</i>	<i>To</i>	<i>Multiply by</i>	<i>To change</i>	<i>To</i>	<i>Multiply by</i>
inches	centimeters	2.540	ounce-inches	Newton-meters	.007062
feet	meters	.305	centimeters	inches	.394
yards	meters	.914	meters	feet	3.280
miles	kilometers	1.609	meters	yards	1.094
square inches	square centimeters	6.451	kilometers	miles	.621
square feet	square meters	.093	square centimeters	square inches	.155
square yards	square meters	.836	square meters	square feet	10.764
square miles	square kilometers	2.590	square meters	square yards	1.196
acres	square hectometers	.405	square kilometers	square miles	.386
cubic feet	cubic meters	.028	square hectometers	acres	2.471
cubic yards	cubic meters	.765	cubic meters	cubic feet	35.315
fluid ounces	milliliters	29,573	cubic meters	cubic yards	1.308
pints	liters	.473	milliliters	fluid ounces	.034
quarts	liters	.946	liters	pints	2.113
gallons	liters	3.785	liters	quarts	1.057
ounces	grams	28.349	liters	gallons	.264
pounds	kilograms	.454	grams	ounces	.035
short tons	metric tons	.907	kilograms	pounds	2.205
pound-feet	Newton-meters	1.356	metric tons	short tons	1.102
pound-inches	Newton-meters	.11296			

Temperature (Exact)

°F	Fahrenheit temperature	5/9 (after subtracting 32)	Celsius temperature	°C
----	------------------------	----------------------------	---------------------	----

